

ICC-ES Evaluation Report

ESR-1722

Reissued March 1, 2012

This report is subject to renewal May 1, 2014.

www.icc-es.org | (800) 423-6587 | (562) 699-0543

A Subsidiary of the International Code Council®

DIVISION: 09 00 00—FINISHES
Section: 09 53 00—Acoustical Ceiling Suspension Assemblies

REPORT HOLDER:

KEEL MANUFACTURING, INC.
 POST OFFICE BOX 450
 SUN PRAIRIE, WISCONSIN 53590
 (608) 825-2080
www.keelfmg.com
keel@keelfmg.com

EVALUATION SUBJECT:

KEELGRID® FIBERGLASS AND PVC SUSPENDED CEILING FRAMING SYSTEM

1.0 EVALUATION SCOPE

Compliance with the following code:

2006 *International Building Code*® (IBC)

Property evaluated:

Structural

2.0 USES

The KEELGRID® Fiberglass and PVC Ceiling Suspension System is a ceiling framing system used primarily to support acoustical tile or acoustical lay-in panels in non-fire-resistance rated, interior applications. Use of the system is limited to Seismic Design Categories A, B and C.

3.0 DESCRIPTION
3.1 General:

The KEELGRID® Fiberglass and PVC Ceiling Suspension System consists of direct-hung ceiling framing system with pultruded thermoset polyester and fiberglass composite framing members, which have an inverted-tee section with dimensions and allowable loads as set forth in Table 1 of this report. The system components include main runners, cross tees, wall angles, clips and accessories.

3.2 Materials:

3.2.1 Main Runners: Main runners consisting of No. 6000 members are classified as light duty in accordance with ASTM C 635 (IBC). The main runners are inverted tee sections 1.390 inches high (35 mm), with a 1.375-inch (35 mm) face and three 0.050-inch (1.27 mm) triangular-shaped ridges running along each side of the main direction of the vertical part of the tee. The face of the tee is 0.125 inch (3.2 mm) thick and the vertical stem of the tee is 0.10 inch (2.5 mm) thick, excluding the triangular-shaped ridges. Predrilled 0.15-inch-diameter (3.81 mm) holes, located 0.58 inch (14.7 mm) down from the top of the tee,

are spaced every 12¹/₁₆ inches (306.4 mm) along the tee, beginning 6¹/₃₂ inches (153 mm) from each end of the runner. Precut ³/₈-inch-wide (9.5 mm) notches in the top of the vertical legs are spaced every 24¹/₈ inches (613 mm), beginning 12¹/₁₆ inches (306.4 mm) from the end of the main runner. Overall length of the member is 144³/₄ inches (3677 mm). Figure 1 illustrates the cross section.

3.2.2 Cross Tee: Cross-tee profile and composition are the same as those of the main runner tee. Cross tees are not predrilled for suspension wires. A precut ³/₈-inch-wide (9.5 mm) notch in the top of the vertical leg is centered in the middle of the 47⁷/₈-inch (1216 mm) cross tees, but the vertical leg of 23³/₄-inch (603 mm) cross tees is not notched. Approximately ¹/₂ inch (12.7 mm) of the face is removed from each end of the cross tees to bridge the cross tee to wall molding, main tees or other cross tees. Number 6010 cross tees are nominally 4 feet (1219 mm) long, and No. 6015 cross tees are nominally 2 feet (610 mm) long.

3.2.3 Clips: The clips are manufactured from polyvinyl chloride (PVC). PVC used in the clips meets the requirements of ASTM D 1784, cell classification 16344, and shall have a minimum tensile strength of 4,800 psi (33 Mpa). U-shaped clips are used to splice main runners, to join cross tees to main runners, to lock cross-tee clips in place, and to bridge from fiberglass tees to wall molding. The wall clip (No. 5010), the main runner splice clips (No. 5020) and cross-tee clips (No. 5035) are produced in the same 1⁵/₈-inch-high (41.3 mm) profiles, with three pairs of internal triangular grooves corresponding to the triangular ridges on the fiberglass tee. The cross-tee clip is 8 inches (203 mm) long and has a 0.20-inch-wide (5.1 mm) notch cut 1 inch (25 mm) deep into the middle of the clip. Splice clips, for the main runner joint or for bridging to wall molding, are 6 inches (152 mm) long and are not notched. Wall clips are 4 inches (102 mm) long and have two 2-inch (51 mm) perpendicular tabs (see Figure 2). The tabs are predrilled for attachment through the wall angle and into the wall. The wall clip is predrilled for fasteners. Lock clips (No. 5040) for locking the cross-tee clips in place are 2¹/₈ inches (54 mm) tall and 4 inches (102 mm) long, and have a 0.34-inch-wide (8.6 mm) notch, cut 1⁵/₈ inches (41.3 mm) deep, centered in the clip. Three pairs of internal triangular grooves, corresponding to the fiberglass tee ridges, are also located in the lock clip, and correspond to the ridges on the main tee.

3.2.4 Wall Angle: The fiberglass wall angle (No. 5060) is a 0.125-inch-thick (3.2 mm) angle section with equal 1.5-inch-by-1.5-inch (38 mm by 39 mm) legs. It is 96 inches (2438 mm) long.

3.2.5 Hanger Wire: Hanger wire for suspended ceilings, and any fixtures, must comply with IBC Section 2506.2.1.

3.2.6 Accessories: Each suspended ceiling system is provided with the necessary angles, clips, molding, and corner caps to meet the requirements of the installation.

4.0 INSTALLATION

4.1 General:

The suspended ceiling framing system must be installed in accordance with this report and the manufacturer's published installation instructions. The suspended ceiling framing system must be installed in accordance with IBC Section 803.9.1.1. Light-fixtures may be included in the ceiling, provided the light-fixtures are supported as described in Section 4.3.

4.2 Main Runners and Cross Tees:

Main runners must be installed and leveled to within $\frac{1}{4}$ inch in 10 feet (6.4 mm in 3048 mm) in jurisdictions enforcing the IBC or $\frac{1}{8}$ inch in 12 feet (3.2 mm in 3660 mm) in jurisdictions enforcing the UBC, with the supporting wire taut. Vertical support hanger wire must be installed within 3 inches (51 mm) of the main runner. The design loads for main runners must be less than or equal to the capacities allowed in Table 1 of this report. Supports for the main runners that consist of vertical hangers and perimeter hangers, must be installed in accordance with the applicable code.

Main runners, or other cross tees, must support cross tees to within $\frac{1}{32}$ inch (0.80 mm) of the required center-to-center spacing. This tolerance must be noncumulative beyond 12 feet (3658 mm). Intersecting runners must be installed to form a right angle to the supporting members.

Main runners and cross tees shall be located in such a manner that allowable loads are within the values set forth in Table 1 of this report. Supports, consisting of perimeter members, hanger wires and other main runners and cross tees, shall be positioned to maintain spans found in Table 1 of this report. The supporting structure shall support all suspended ceiling loads to the satisfaction of the code official.

Main runners shall be spaced at $24\frac{1}{8}$ inches (613 mm) or $48\frac{1}{4}$ inches (1226 mm) on center and cross tees shall be spaced $24\frac{1}{8}$ inches (613 mm) for the standard 2-foot-by-4-foot (603 mm by 1213 mm) lay-in-panels. Cross tees and main runners shall be cut to length to butt to the outstanding leg of the wall angle around the room's perimeter. Main runners and cross tees shall use wall clips where the tee butts to the wall angle. The wall clip rests on top of the angle (see Figure 2). Attachment of the wall clip to the wall is typically required on two adjacent walls. On walls where the main runners and cross tees are to be unattached to the wall, the wall clips are not fastened to the wall. A splice clip may be used as an alternative to an unattached wall clip. The wall angles shall be secured to the wall at the desired elevation around the perimeter of the room with noncorroding fasteners at a maximum of 24 inches (610 mm) on center. The holes for the fasteners in the wall angle shall be predrilled. Splice clips shall be installed at all main-to-main junctions (see Figure 3). Cross tees shall be assembled to the main runners using cross-tee clips. Lock clips shall be installed at these intersections to assure a positive connection (see Figure 4). All splice and junction clips shall be connected with pop rivets having shear strength equal to or greater than $\frac{1}{8}$ -inch-diameter (3 mm) stainless steel pop rivets with back-up washers. One rivet on each side of the clip shall be installed and it shall be a minimum of 1 inch (25 mm) from the end of the clip (see Figure 4). The rivet shall be placed below the first rib on the KEELGRID web, $\frac{9}{16}$ inch (14.3 mm) from the top of the web.

4.3 Fixtures:

Lighting fixtures must be supported directly from the structure above the ceiling by hanger wires or other methods approved by the code official.

4.4 Partitions:

Partitions must be laterally supported as required by Section 13.5.8 of ASCE 7 referenced by IBC Section 1613 or UBC Standard 25-2, Section 25.211.1, as applicable.

4.5 Seismic Design:

Seismic design and installation details of the ceiling system must be in accordance with IBC Section 1613, ASCE 7 Section 13.5.6.2, and CISCA 0-2. CISCA 0-2 is referenced in ASCE 7, Section 13.5.6.2, and ASCE 7 is referenced in IBC Section 1613. Design loads and spans of framing members must not exceed the allowable loads and spans stated in Table 1. The design load in tension and compression for each framing member connection must not exceed 30 pounds (133.5 N). The system is limited to use in Seismic Design Categories A, B and C.

5.0 CONDITIONS OF USE

The KEELGRID® Fiberglass and PVC Ceiling Suspension System described in this report complies with, or is a suitable alternative to what is specified in, those codes listed in Section 1.0 of this report, subject to the following conditions:

- 5.1 The ceiling suspension system shall be fabricated and installed in accordance with this report and the manufacturer's published installation instructions, copies of which shall be available to the code official at the jobsite during construction. In the event of a conflict between the manufacturer's installation instructions and this report, this report governs.
- 5.2 Suspended ceiling systems must be designed in accordance with ASCE 7, Section 13.5.6. The documents must be prepared by a registered design professional where required by statutes of the jurisdiction in which the project is to be constructed.
- 5.3 For seismic design category C, a quality assurance plan complying with ASCE 7 Section 11A, must be submitted to the code official.
- 5.4 The ceiling framing system must not be used to provide lateral support for walls or partitions, except as noted in Section 4.4 of this report.
- 5.5 The supporting construction for the ceiling system has not been evaluated and is outside the scope of this report. The code official must approve the floor or roof construction supporting the suspended ceiling system.
- 5.6 The ceiling system is limited to interior applications.
- 5.7 Lay-in ceiling panels must be justified to the satisfaction of the code official as complying with the interior finish requirements of Chapter 8 of the applicable code.
- 5.8 The ceiling systems are limited to ceilings not considered accessible in accordance with Item 32 of IBC Table 1607.1 titled Minimum Uniformly Distributed Live Loads and Minimum Concentrated Live Loads.

6.0 EVIDENCE SUBMITTED

Data in accordance with ICC-ES Acceptance Criteria for Suspended Ceiling Framing Systems (AC368), February 2007.

7.0 IDENTIFICATION

The framing system is identified by labels on the shipping cartons, showing the name and address of Keel Manufacturing, Inc., part name and number and the evaluation report number (ESR-1722).

TABLE 1—ALLOWABLE LOADS AND SPANS FOR MAIN AND CROSS TEES FOR A 4-FOOT SPAN

PART NUMBERS	MAXIMUM SPAN (feet)	UNIFORM LOAD (pounds per foot)	CONCENTRATED LOAD AT MIDSPAN (pounds)	ALLOWABLE SPACING BETWEEN LATERAL BRACING (inches)
6000 6010 6015	4	9	18	48.25

For SI: 1 foot = 304.8 mm, 1 inch = 25.4 mm, 1 plf = 14.59 N/m, 1 lbf = 4.448 N.

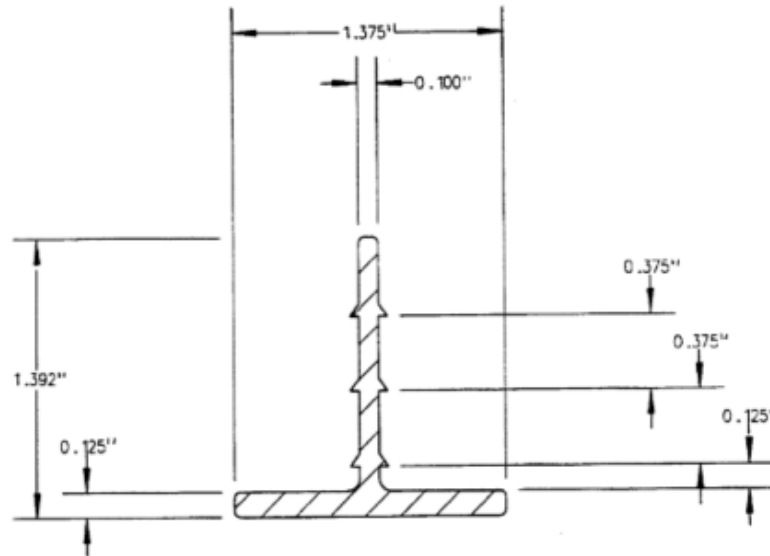

For SI: 1 inch = 25.4 mm.

FIGURE 1—TEE CROSS SECTION

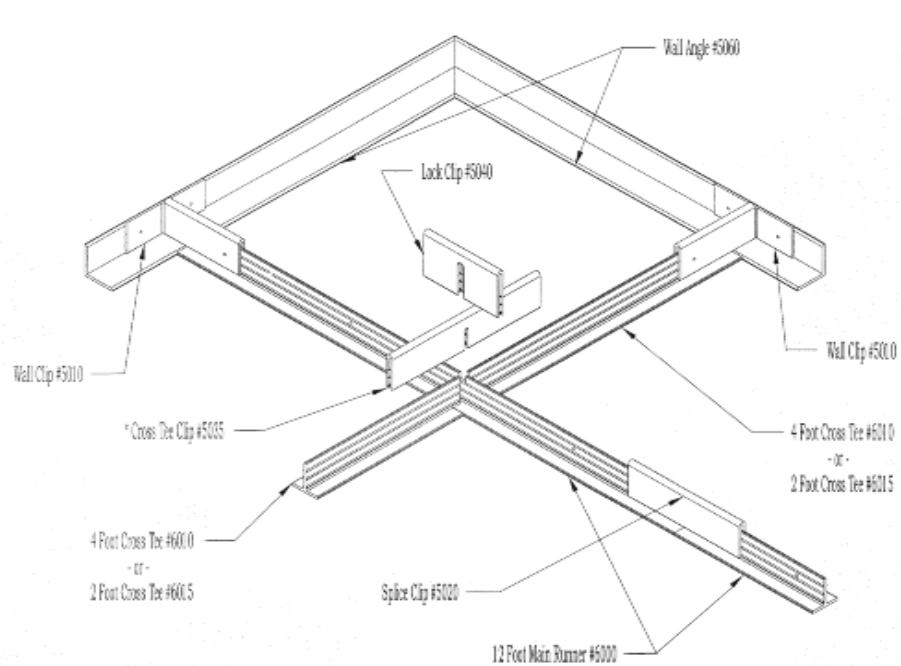

* 5035 used at pre-notched locations on Main Runner - #5020 used at non-notched locations

FIGURE 2

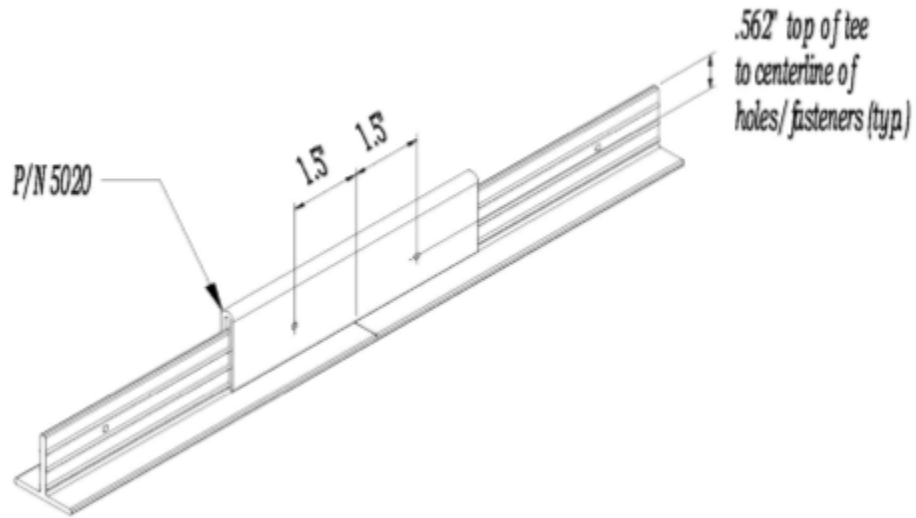

FIGURE 3

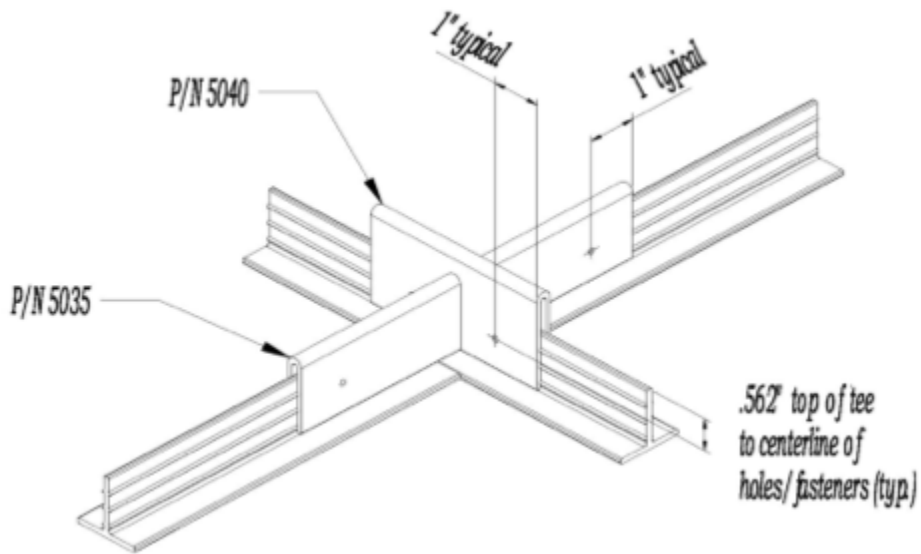

FIGURE 4