

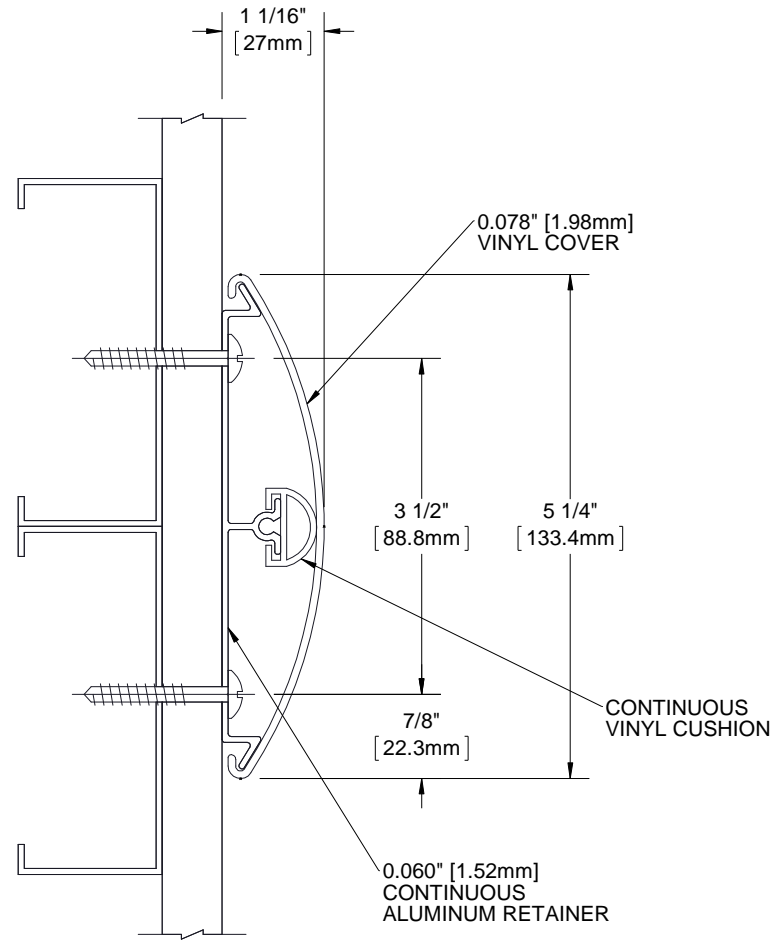

QUANTITY

COLOR



NOTES:

1. **PROFILE:** HIGH IMPACT VINYL ACRYLIC EXTRUSION LOCKED IN PLACE, NOMINAL 0.078" (1.98mm) THICK
2. CLASS A FIRE RATING, TESTED TO ASTM E84
3. **RETAINER:** CONTINUOUS 6063 T-5 ALUMINUM RETAINER, NOMINAL 0.062" (1.52mm) THICK
4. **EXTRUSION:** PEBBLE GRAIN FINISH WHICH CONTAINS EPA REGISTERED MICRO-CHEK ANTIMICROBIAL AGENT
5. **VINYL CRASH RAIL LENGTH:** PROVIDED IN 20' CONTINUOUS SECTIONS
6. END CAP: #BCRVS5C-ECT, OUTSIDE CORNER: #BCRVS5C-OCT, 135 DEG OUTSIDE CORNER: #BCRVS5C-OC135, SPLICE KIT: #BCRVS5C-SK
7. FASTENERS AND PARTITION COMPONENTS PROVIDED BY OTHERS.

PROJECT:					
ARCHITECT:					
CONTRACTOR:					
 9300 73rd Avenue North Brooklyn Park, MN 55428		TITLE: 5" VINYL CRASH RAIL CRESCENT SHAPE, SURFACE MOUNT CONTINUOUS RETAINER			
		NAME	DATE	SIZE	DWG. NO.
DRAWN	MDS	24APR13	A	BCRVS5C	A
RELEASED	PGE	01MAY13	WEIGHT: 0.90 lbs/ft	SHEET 1 OF 1	

PROPRIETARY AND CONFIDENTIAL: THE INFORMATION CONTAINED IN THIS DRAWING IS THE SOLE PROPERTY OF BABCOCK-DAVIS. ANY REPRODUCTION IN PART OR AS A WHOLE WITHOUT THE WRITTEN PERMISSION OF BABCOCK-DAVIS IS PROHIBITED.