

QUANTITY

COLOR

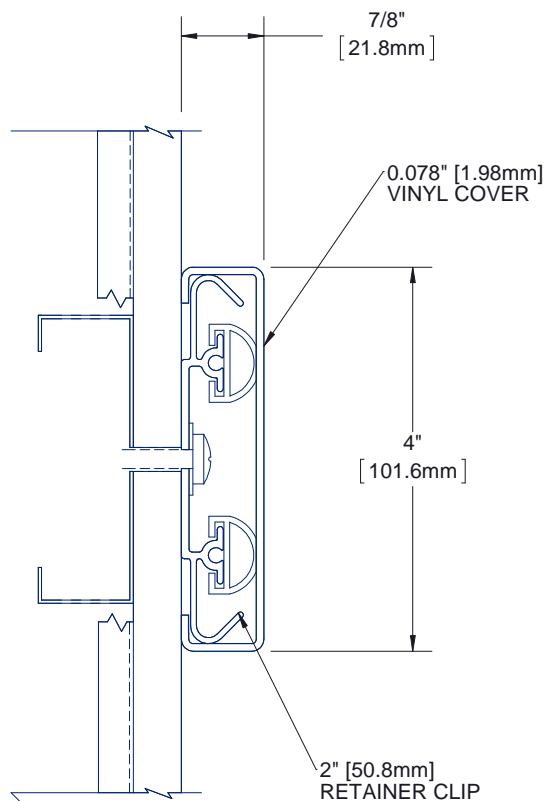

NOTES:

1. **PROFILE:** HIGH IMPACT VINYL ACRYLIC EXTRUSION LOCKED IN PLACE, NOMINAL 0.078" (1.98mm) THICK
2. CLASS A FIRE RATING, TESTED TO ASTM E84
3. **RETAINER:** 6063 T-5 ALUMINUM RETAINER CLIP, NOMINAL 0.080" (2.03mm) THICK X 2" WIDE
4. **EXTRUSION:** PEBBLE GRAIN FINISH WHICH CONTAINS EPA REGISTERED MICRO-CHEK ANTIMICROBIAL AGENT, 1-1/2" IS SMOOTH SATIN FINISH
5. **VINYL CRASH RAIL LENGTH:** PROVIDED IN 20' CONTINUOUS SECTIONS
6. END CAP: #BCRVS4E-EC, OUTSIDE CORNER: #BCRVS4E-OC, INSIDE CORNER: #BCRVS4E-IC, SPLICE KIT: #BCRVS4E-SK
7. FASTENERS AND PARTITION COMPONENTS PROVIDED BY OTHERS.

PROPRIETARY AND CONFIDENTIAL: THE INFORMATION CONTAINED IN THIS DRAWING IS THE SOLE PROPERTY OF BABCOCK-DAVIS. ANY REPRODUCTION IN PART OR AS A WHOLE WITHOUT THE WRITTEN PERMISSION OF BABCOCK-DAVIS IS PROHIBITED.

PROJECT:					
ARCHITECT:					
CONTRACTOR:					
		TITLE: 4" VINYL CRASH RAIL SURFACE MOUNT, END CAP ECONOMY 2" CLIP MOUNTING			
		NAME	DATE	SIZE	DWG. NO.
DRAWN	MDS	26APR13	A	BCRVS4E	A
RELEASED	PGE	01MAY13	WEIGHT: 0.299 lbs/ft	SHEET 1 OF 1	