

B

B

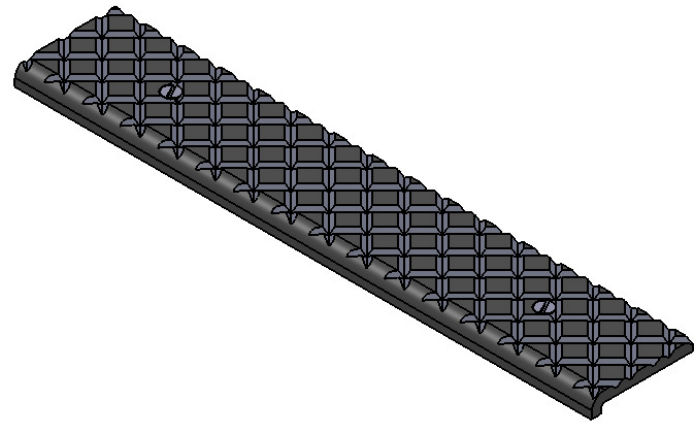
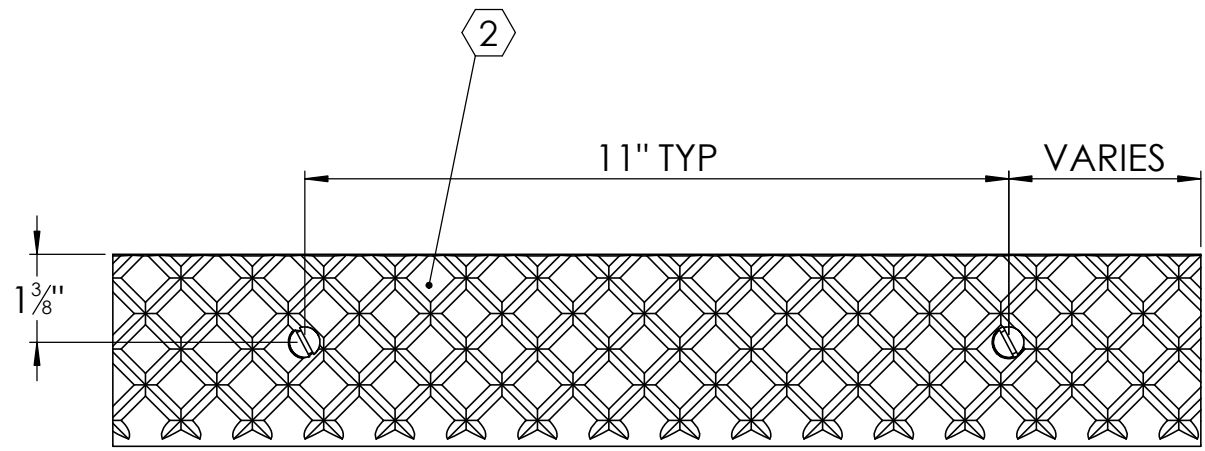

A

A

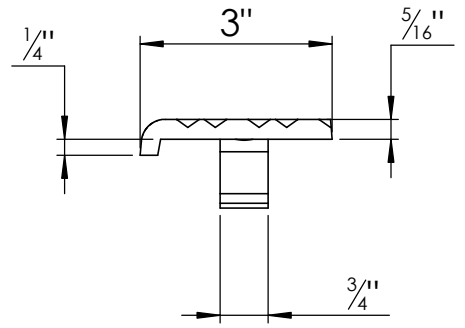
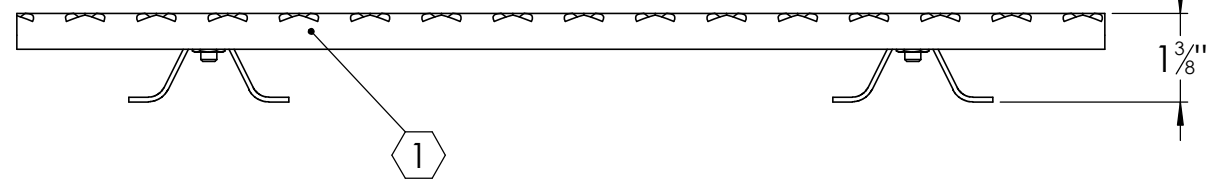

**SPECIFICATIONS:**

- ① **BASE: 319 CAST ALUMINUM**
- ② **ABRASIVE: SILICON CARBIDE ABRASIVE , CROSSHATCH PATTERN 1/8" DEEP**
- 3. **FINISH: SAND CAST**
- 4. **POURED CONCRETE STAIRS: NOSING SHALL TERMINATE NO MORE THEN 3" FROM END OF STEPS**
- 5. **LENGTH: 6" MINIMUM 6'-0" MAXIMUM**
- 6. **WING ANCHORS: STANDARD FOR POURED CONCRETE APPLICATIONS; STEEL ANCHORS AND STAINLESS STEEL HARDWARE**

LENGTH ±1/8	QTY

PROJECT:					
ARCHITECT:					
CONTRACTOR:					
QTY:					
PART#:		<b>BSTCA-C3W</b>			
 <b>Babcock-Davis</b> <small>Always right there.</small> 9300 73rd Avenue North Brooklyn Park, MN 55428		TITLE:			
		Stair Tread, Cast Series 3", Cast Aluminum Crosshatch Short Nosing for Concrete, Wing Anchor			
	NAME	DATE	SIZE	DWG. NO.	REV
DRAWN	SJB	3/31/11	A	BSTCA-C3W	A
RELEASED	DWO	3/31/11	WEIGHT: 1.20 LB/FT		SHEET 1 OF 1

PROPRIETARY AND CONFIDENTIAL: THE INFORMATION CONTAINED IN THIS DRAWING IS THE SOLE PROPERTY OF BABCOCK-DAVIS. ANY REPRODUCTION IN PART OR AS A WHOLE WITHOUT THE WRITTEN PERMISSION OF BABCOCK-DAVIS IS PROHIBITED.