

SPECIFICATIONS:

1 COVER: 1/4" ALUMINUM COVER STIFFENED TO WITHSTAND A LIVE LOAD OF 40PSF WITH A MAX DEFLECTION OF 1/150 OF THE SPAN

2 LINER: 18 GA ALUM

3 CURB AND COUNTERFLASH W/ EZ TAB: 1/4" ALUM

4 FINISH: MILL FINISH

5 SPRING/HINGE ASSEMBLY: ZINC PLATED STEEL TAMPER-PROOF HINGE CONTAINED WITHIN SPRING/HINGE ASSEMBLY. TELESCOPIC TUBES CONTAIN COIL STEEL COMPRESSION SPRINGS FOR LIFT ASSISTANCE

6 HOLD OPEN ARM: LOCKS COVER IN FULLY OPEN POSITION - ZINC PLATED STEEL WITH RED VINYL GRIP HANDLE PULL RELEASE

7 LATCH: SINGLE POINT LATCH SLAM LATCH HOLDS COVER CLOSED AGAINST 20 PSF WIND UPLIFT. INTERNAL AND EXTERNAL TURN HANDLES WITH PADLOCK HASPS

8 INSULATION: 1" POLYSTYRENE (R4) IN COVER, AND 1" FIBERBOARD (R2.8) IN CURB

9 GASKET: ADHESIVE BACKED EPDM RUBBER EXTRUSION

10 SIZING: WIDTH X LENGTH DIMENSIONS ARE MEASURED INSIDE CURB TO INSIDE CURB WHERE THE WIDTH IS HINGE TO LATCH AND LENGTH IS HINGED SIDE WITH SPRINGS

ROOF HATCH SIZE " (WIDTH) x " (LENGTH)

CLEAR OPENING " (WIDTH) x " (LENGTH)

ROUGH OPENING " (WIDTH) x " (LENGTH)

PROPRIETARY AND CONFIDENTIAL: THE INFORMATION CONTAINED IN THIS DRAWING IS THE SOLE PROPERTY OF BABCOCK-DAVIS. ANY REPRODUCTION IN PART OR AS A WHOLE WITHOUT THE WRITTEN PERMISSION OF BABCOCK-DAVIS IS PROHIBITED.

PROJECT:				
ARCHITECT:				
CONTRACTOR:				
QTY:				
PART#:				
 Babcock-Davis <small>Always right there.</small> 9300 73rd Avenue North Brooklyn Park, MN 55428		TITLE: Roof Hatch, Security Series, Sngl Dr, Zinc Hdw, Alum, Mill, Sngl Wall Curb,		
		DWG. NO.		
NAME	DATE	SIZE	DWG. NO.	REV
ELW	10/16/12	A		A
RELEASED	-	-	WEIGHT: VARIES	SHEET 1 OF 2

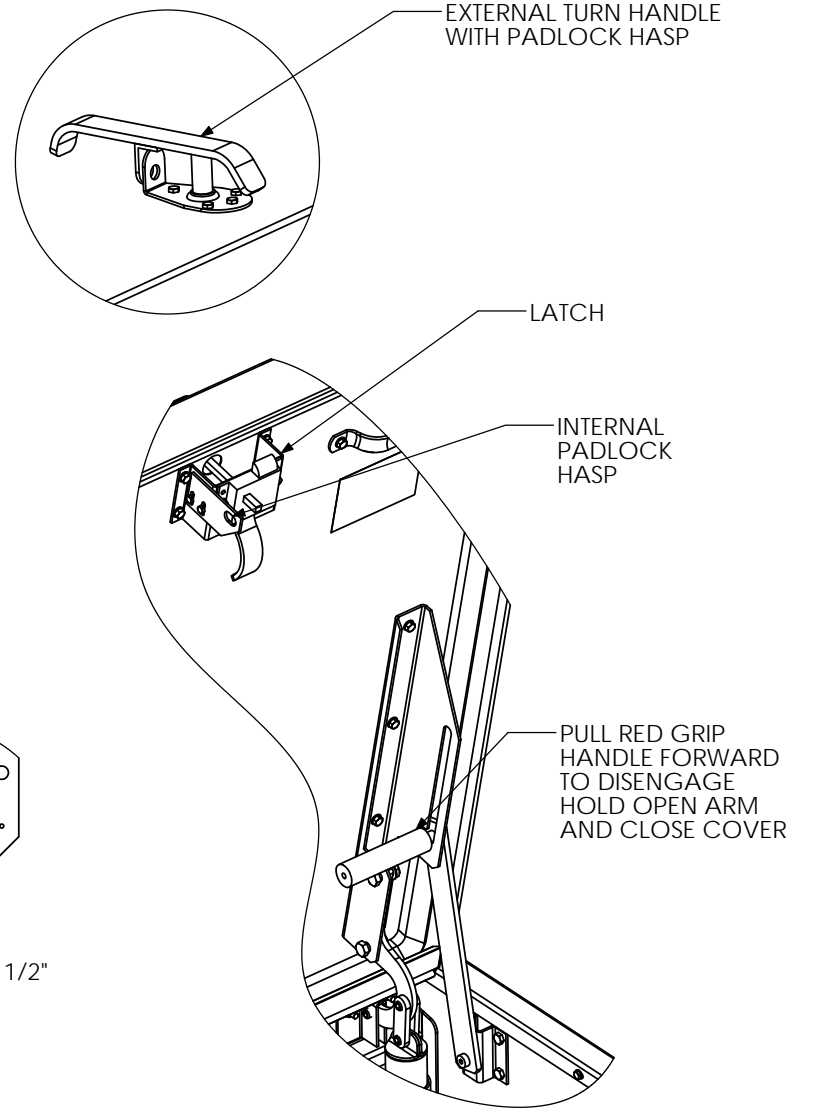
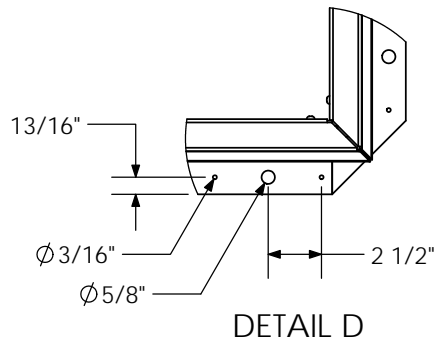
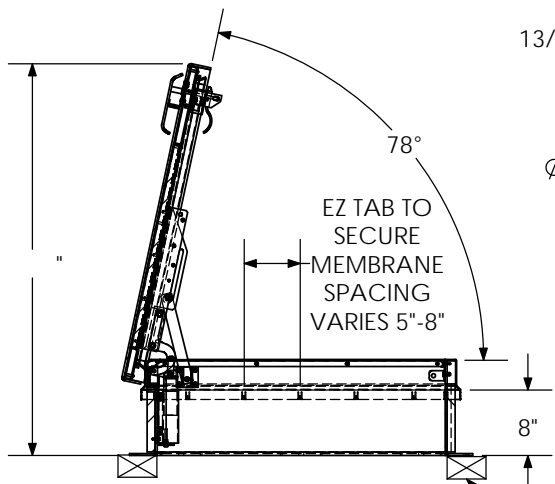
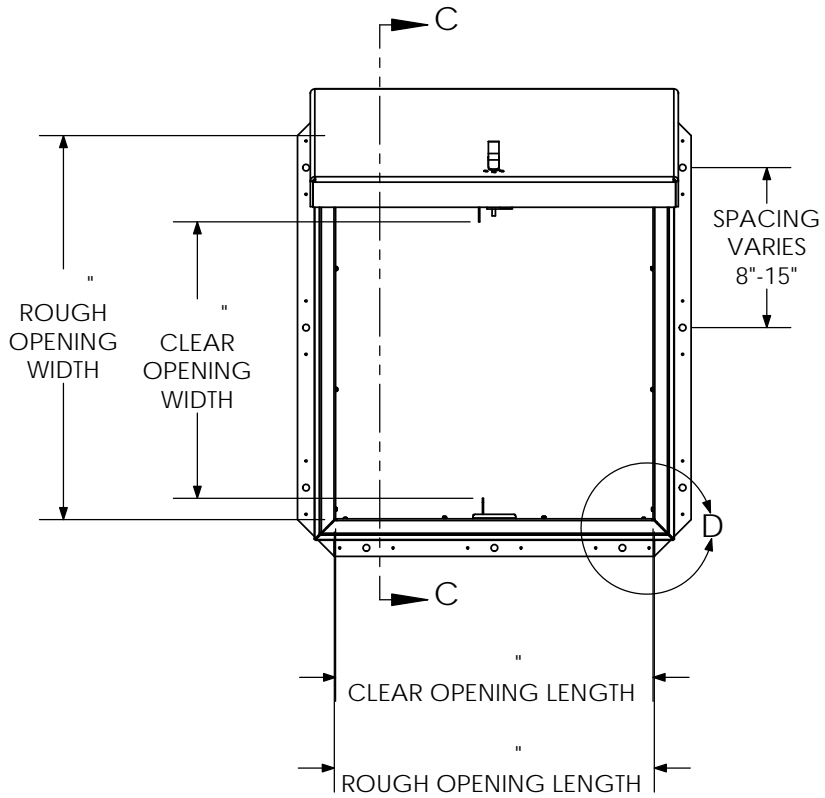

HARDWARE DETAILS

WOOD, CONCRETE, OTHER MATERIAL FOR MOUNTING BY OTHERS (NIC)

SECTION C-C

<p>Babcock-Davis Always right there. 9300 73rd Avenue North Brooklyn Park, MN 55428</p>			<p>TITLE: Roof Hatch, Security Series, Sngl Dr, Zinc Hdw, Alum, Mill, Sngl Wall Curb,</p>		
	NAME	DATE	SIZE	DWG. NO.	REV
DRAWN	ELW	10/16/12	A		A
RELEASED	-	-	WEIGHT: VARIES		SHEET 2 OF 2

PROPRIETARY AND CONFIDENTIAL: THE INFORMATION CONTAINED IN THIS DRAWING IS THE SOLE PROPERTY OF BABCOCK-DAVIS. ANY REPRODUCTION IN PART OR AS A WHOLE WITHOUT THE WRITTEN PERMISSION OF BABCOCK-DAVIS IS PROHIBITED.