

ENVIRON Tread II®

ISO VIEW

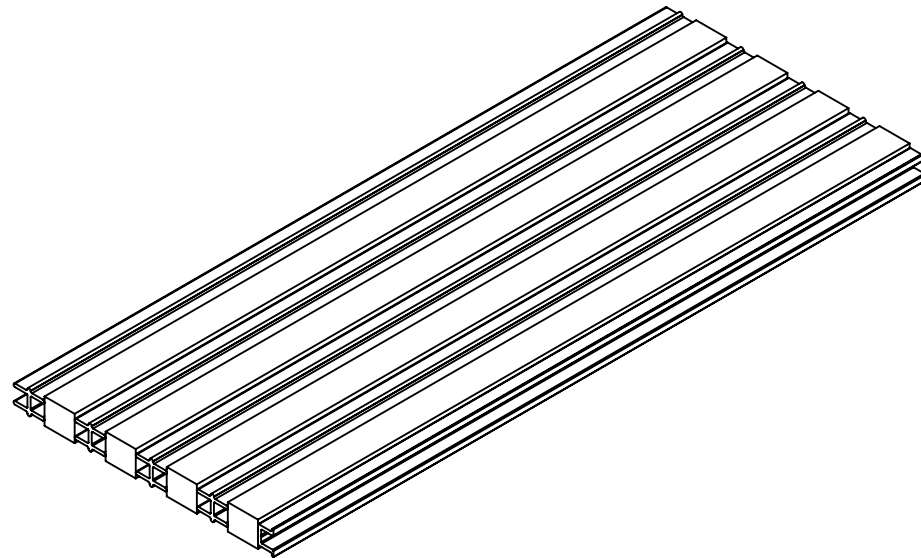
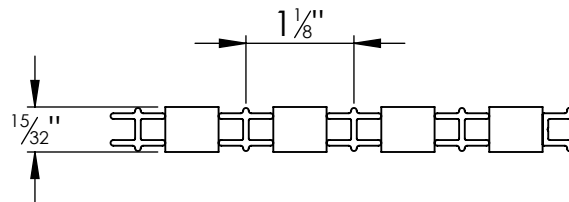

WIDTH VIEW

Detail notes:

1. Tread rails must run perpendicular to traffic direction.
2. Grate dimensions allow for clearance between grate sections and frame in the width dimension only.

Specifications:

Model G-212 EnvironTread II reversible grate is 15/32" (11.9mm) deep with alternating 6063-T6 aluminum alloy divider bars and recycled buffed rubber treads. Spaced 1-1/8" (28.6mm) on center. Assembled with .105" (2.7mm) diameter galvanized steel wire, 1-1/2" (38.1mm) on center.

Frame options:

- F-13, level bed
- F-12, surface mount

PROJECT:					
ARCHITECT:					
CONTRACTOR:					
 9300 73rd Avenue North Brooklyn Park, MN 55428		DESCRIPTION:			
		EnvironTread II Grate Gray Recycled Buffed Rubber Tread Reversible Tread			
	NAME	DATE	SIZE	MODEL NO.	REV
DRAWN	MDS	1/12/12	A	G-212	A
RELEASED	PGE	3/8/12	SCALE: NTS		SHEET 1 OF 1