

Wallwear® Integrated Wall Protection Systems

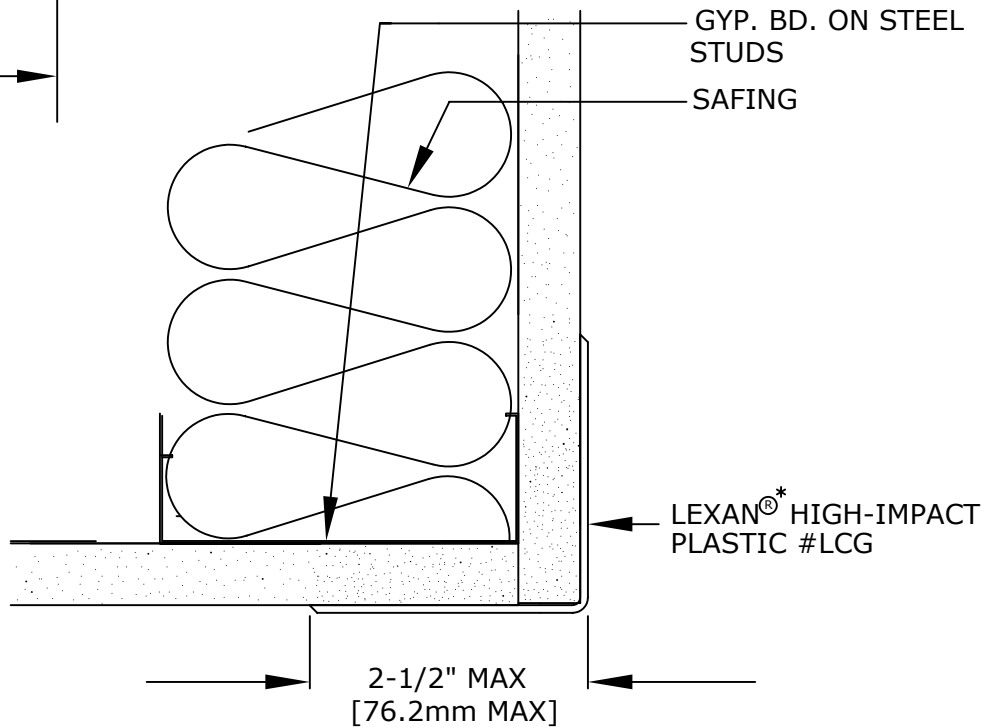
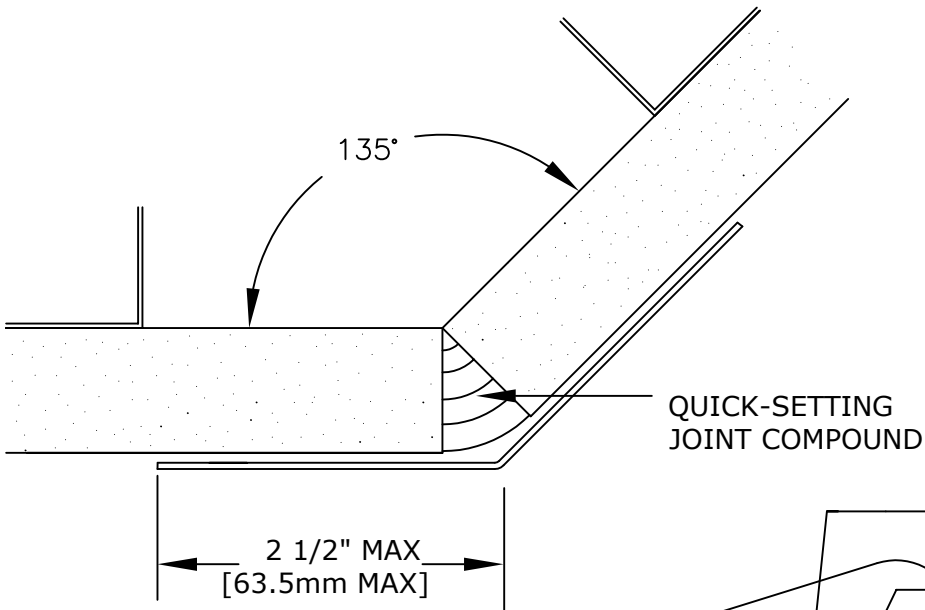

WING SIZE	HEIGHT	QTY	ANGLE
W	H	Q	A
W	H	Q	A
W	H	Q	A
W	H	Q	A
W	H	Q	A
W	H	Q	A
W	H	Q	A
W	H	Q	A
W	H	Q	A
W	H	Q	A
W	H	Q	A
W	H	Q	A
W	H	Q	A
W	H	Q	A
W	H	Q	A

LEXAN® CORNER GUARD

*LEXAN IS A REGISTERED TRADEMARK OF GENERAL ELECTRIC.

IMPORTANT: USER SHALL VERIFY CONFORMANCE OF ALL CONSTRUCTIONS SHOWN WITH LOCAL CODES AND WITH REQUIREMENTS OF METAL STUD MANUFACTURER FOR RATINGS. FASTENERS AND PARTITION COMPONENTS NOT BY ARDEN ARCHITECTURAL SPECIALTIES, INC.

SURFACE MOUNT CORNER GUARDS	DATE:	SCALE:
-----------------------------	-------	--------

<p><u>GENERAL SPECIFICATION</u></p> <p>MATERIAL: CLEAR POLYCARBONATE, IN ACCORDANCE WITH ASTM D 1929, 0.1" [2.54mm] THICK</p> <p>CONTINUOUS LENGTH AVAILABLE: 18' (5.49m) MAXIMUM</p> <p>MOUNTING: STANDARD PRE-DRILLED HOLES WITH SCREWS. OPTIONAL DOUBLE SIDED TAPE.</p>	PROJECT:
	ARCHITECT:
	CONTRACTOR:
	REPRESENTATIVE:



151 FIFTH AVE. NW SUITE J ST. PAUL, MN 55112-3268
TOLL-FREE 800.521.1826 TEL 651.631.1607 FAX 651.631.0251

CUSTOMER:	CUST. NO:	JOB NO:	SHEET OF
-----------	-----------	---------	----------