

**SPECIFICATIONS:**

- ① **DOOR:** STEEL, 3/16" SMOOTH PLATE, RECESSED, GRAY PRIMER COAT WITH A LIVE LOAD OF 300 PSF WITH A MAXIMUM DEFLECTION OF L/160
  - ② **FRAME:** STEEL, 3/16" FORMED, RECESSED, GRAY PRIMER COAT
  - ③ **HINGES:** TYPE 316 STAINLESS STEEL
  - ④ **SLAM LATCH:** TYPE 316 STAINLESS STEEL WITH INSIDE LEVER HANDLE AND OUTSIDE REMOVABLE 5/16" SQUARE L HANDLE
  - ⑤ **COUNTER-BALANCE SPRING:** TYPE 17-7 STAINLESS STEEL SPRING ENCLOSED IN A TYPE 316 STAINLESS STEEL TELESCOPING TUBE
  - ⑥ **HOLD-OPEN ARM:** TYPE 316 STAINLESS STEEL WITH RED VINYL GRIP HANDLE
  - ⑦ **ANCHOR:** 4" CONCRETE ANCHOR STRAPS PROVIDED
  - ⑧ **TILE EXTRUSION:** ALUMINUM, RECESSED FOR 1/8" FLOOR COVERING
- FLOOR DOOR SIZE:** " (WIDTH) x " (LENGTH)  
**CLEAR UNOBSTRUCTED OPENING:** " (WIDTH) x " (LENGTH)  
**OPENING:** " (WIDTH) x " (LENGTH)

PROJECT:					
ARCHITECT:					
CONTRACTOR:					
QTY:					
PART#:		<b>BFDRPP X DAL</b>			
<b>Babcock-Davis</b> <small>Always right there.®</small> <b>9300 73rd Avenue North</b> <b>Brooklyn Park, MN 55428</b>		TITLE: Floor Door, Recessed Series, Dbl Dr, 316 SST Hdw, Steel, Prime Coat, Pedestrian, Cast-In Anchors, Slam Latch Removbl L Hdl			
NAME	DATE	SIZE	DWG. NO.	REV	
DRAWN	JE	04/18/11	A	BFDRPP_X_DAL	A
RELEASED	DWO	04/18/11	WEIGHT: Varies	SHEET 1 OF 2	

PROPRIETARY AND CONFIDENTIAL; THE INFORMATION CONTAINED IN THIS DRAWING IS THE SOLE PROPERTY OF BABCOCK DAVIS. ANY REPRODUCTION IN PART OR AS A WHOLE WITHOUT THE WRITTEN PERMISSION OF BABCOCK DAVIS IS PROHIBITED. THIS IS A GENERIC SHOP DRAWING AND MAY NOT BE AN ACTUAL REPRESENTATION OF THE FINAL PRODUCT.

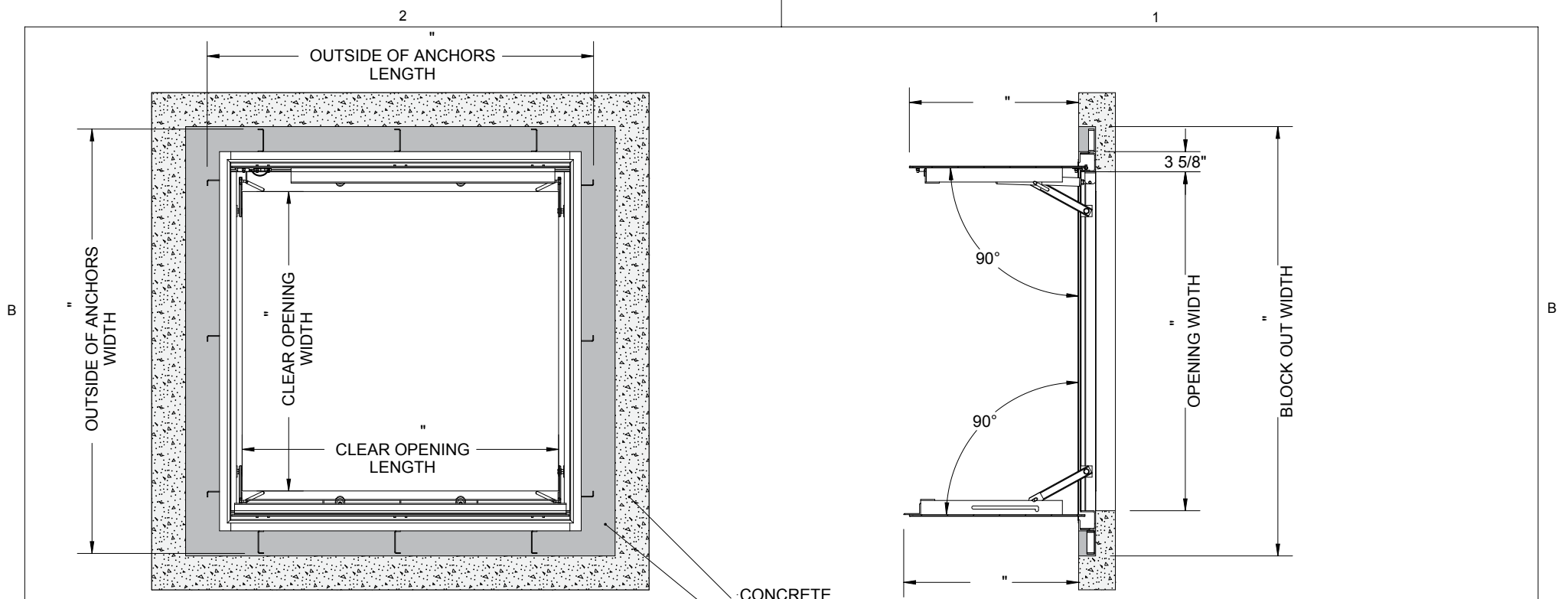

CONCRETE  
BACK POUR AREA

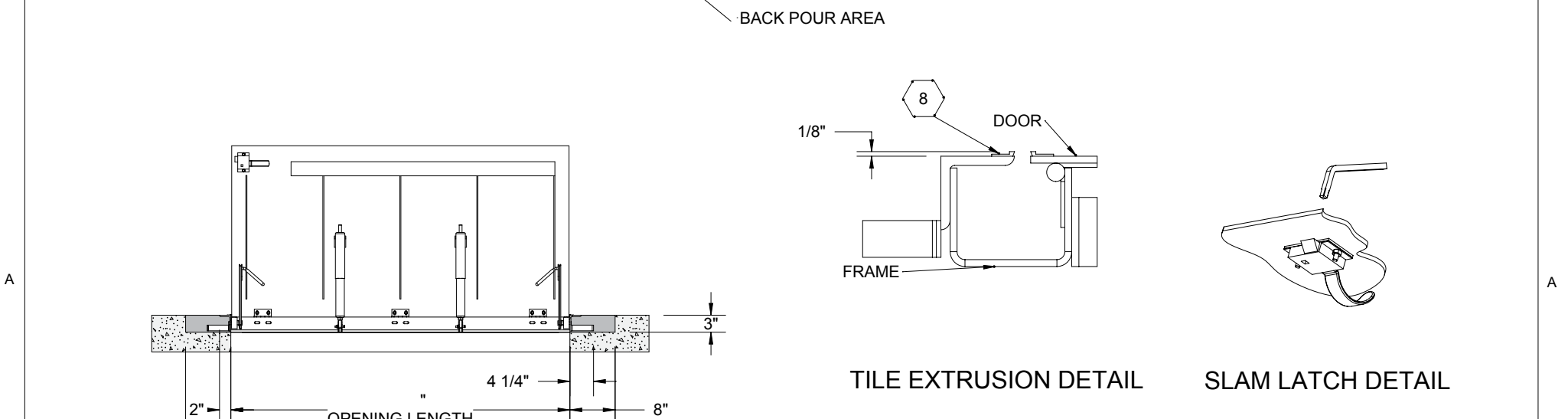

TILE EXTRUSION DETAIL

SLAM LATCH DETAIL

<p><b>Babcock-Davis</b> <i>Always right there.™</i> 9300 73rd Avenue North Brooklyn Park, MN 55428</p>			<p>TITLE: Floor Door, Recessed Series, Dbl Dr, 316 SST Hdw, Steel, Prime Coat, Pedestrian, Cast-In Anchors, Slam Latch Removbl L Hdl</p>		
	NAME	DATE	SIZE	DWG. NO.	REV
DRAWN	JE	04/18/11	A	BFDRPP_X_DAL	A
RELEASED	DWO	04/18/11	WEIGHT: Varies		SHEET 2 OF 2

PROPRIETARY AND CONFIDENTIAL; THE INFORMATION CONTAINED IN THIS DRAWING IS THE SOLE PROPERTY OF BABCOCK DAVIS. ANY REPRODUCTION IN PART OR AS A WHOLE WITHOUT THE WRITTEN PERMISSION OF BABCOCK DAVIS IS PROHIBITED. THIS IS A GENERIC SHOP DRAWING AND MAY NOT BE AN ACTUAL REPRESENTATION OF THE FINAL PRODUCT.