

SPECIFICATIONS:

- ① **DOOR:** STEEL, 3/16" DIAMOND PLATE, GRAY PRIMER COAT WITH A LIVE LOAD OF 300 PSF WITH A MAXIMUM DEFLECTION OF L/160
 - ② **FRAME:** STEEL, 3/16" ANGLE, GRAY PRIMER COAT
 - ③ **HINGES:** TYPE 316 STAINLESS STEEL
 - ④ **SLAM LATCH:** TYPE 316 STAINLESS STEEL WITH INSIDE LEVER HANDLE AND OUTSIDE REMOVABLE 5/16" SQUARE L HANDLE
 - ⑤ **COUNTER-BALANCE SPRING:** TYPE 17-7 STAINLESS STEEL SPRING ENCLOSED IN A TYPE 316 STAINLESS STEEL TELESCOPING TUBE
 - ⑥ **HOLD-OPEN ARM:** TYPE 316 STAINLESS STEEL WITH RED VINYL GRIP HANDLE
 - ⑦ **ANCHOR HOLES:** ANCHOR HOLES PROVIDED FOR BOLTING IN ON SITE
 - ⑧ **FLUSH LIFTING HANDLE:** TYPE 316 STAINLESS STEEL
- FLOOR DOOR SIZE:** " (WIDTH) x " (LENGTH)
- CLEAR UNOBSTRUCTED OPENING:** " (WIDTH) x " (LENGTH)
- OPENING:** " (WIDTH) x " (LENGTH)

PROJECT:					
ARCHITECT:					
CONTRACTOR:					
QTY:					
PART#:		BFDEPP X SB			
Babcock-Davis <small>Always right there.®</small> 9300 73rd Avenue North Brooklyn Park, MN 55428		TITLE: Floor Door, Existing Opening, Sngl Dr, 316 SST Hdw, Steel, Prime Coat, Pedestrian, Bolt-In, Slam Latch Removbl L Hdl			
NAME	DATE	SIZE	DWG. NO.	REV	
DRAWN	JE	04/18/11	A	BFDEPP_X_SB	A
RELEASED	DWO	04/18/11	WEIGHT: Varies	SHEET 1 OF 2	

PROPRIETARY AND CONFIDENTIAL: THE INFORMATION CONTAINED IN THIS DRAWING IS THE SOLE PROPERTY OF BABCOCK DAVIS. ANY REPRODUCTION IN PART OR AS A WHOLE WITHOUT THE WRITTEN PERMISSION OF BABCOCK DAVIS IS PROHIBITED. THIS IS A GENERIC SHOP DRAWING AND MAY NOT BE AN ACTUAL REPRESENTATION OF THE FINAL PRODUCT.

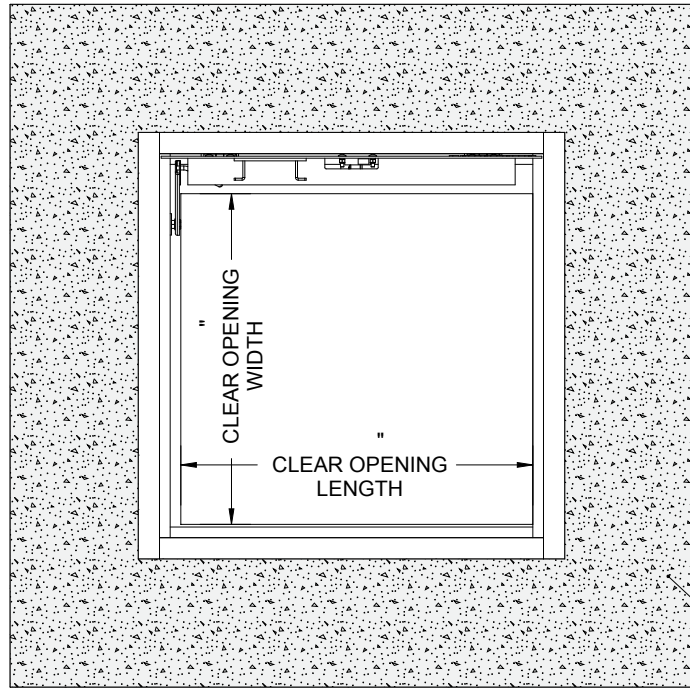

CONCRETE

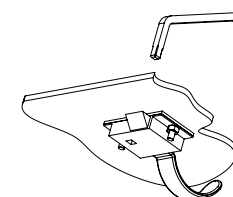
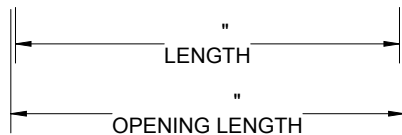
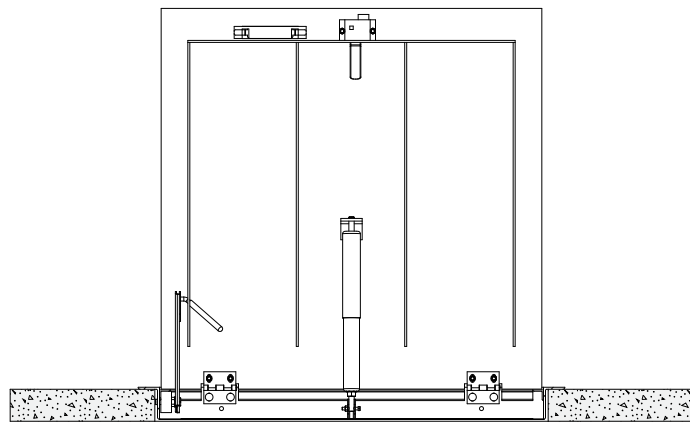
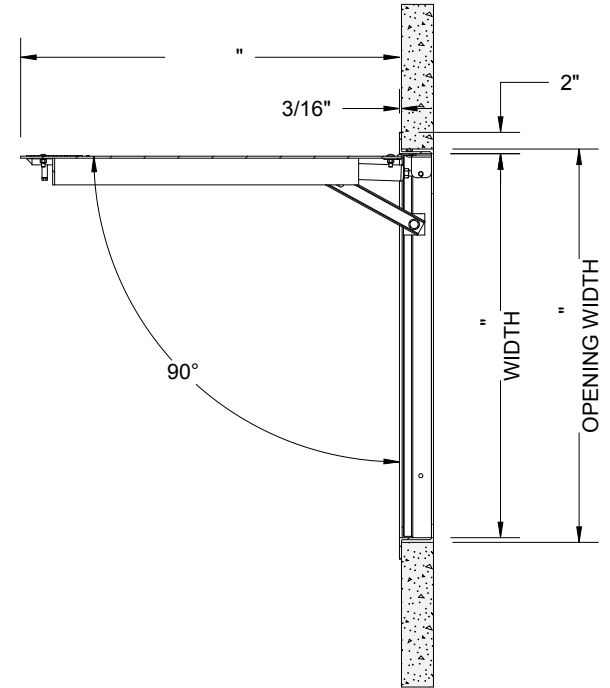

SLAM LATCH DETAIL

 Babcock-Davis <small>Always right there.™</small> 9300 73rd Avenue North Brooklyn Park, MN 55428			TITLE: Floor Door, Existing Opening, Sngl Dr, 316 SST Hdw, Steel, Prime Coat, Pedestrian, Bolt-In, Slam Latch Removbl L Hdl		
	NAME	DATE	SIZE	DWG. NO.	REV
DRAWN	JE	04/18/11	A	BFDEPP_X_SB	A
RELEASED	DWO	04/18/11	WEIGHT: Varies		SHEET 2 OF 2

PROPRIETARY AND CONFIDENTIAL; THE INFORMATION CONTAINED IN THIS DRAWING IS THE SOLE PROPERTY OF BABCOCK DAVIS. ANY REPRODUCTION IN PART OR AS A WHOLE WITHOUT THE WRITTEN PERMISSION OF BABCOCK DAVIS IS PROHIBITED. THIS IS A GENERIC SHOP DRAWING AND MAY NOT BE AN ACTUAL REPRESENTATION OF THE FINAL PRODUCT.