

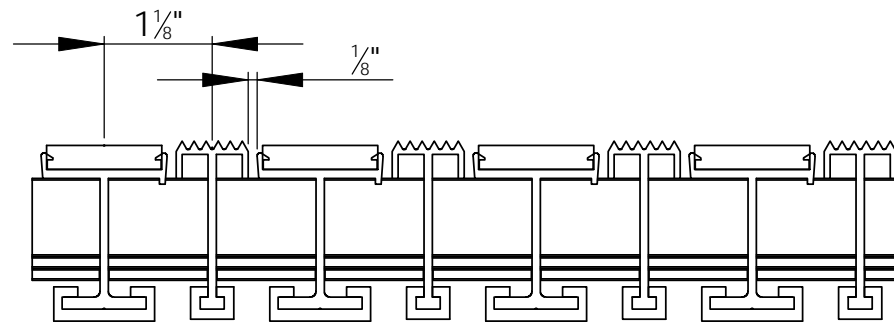

G-525DKU GRATE DETAIL

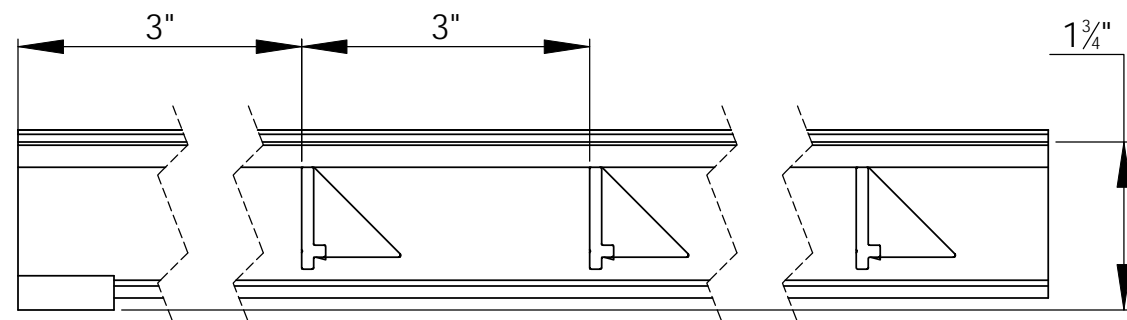

WIDTH VIEW



LENGTH VIEW

OUR SCRAPESGRATE ENTRANCE MATS HAVE SCRAPER BARS THAT ALTERNATE WITH AN ABSORBENT ULTRASORB TREAD FOR INDOOR USE OR HEAVY-DUTY RUGGED SCRUB FOR OUTDOOR USE. WATER AND DIRT ARE SCRAPED OFF AND FUNNELED UNDER THE MAT AT THE DOOR SO THE FLOOR STAYS CLEAN. THIS PRODUCT CARRIES A FIVE YEAR WARRANTY.

DETAIL NOTES:

- 1-TREAD RAILS MUST RUN PERPENDICULAR TO TRAFFIC DIRECTION.
- 2-GRATE DIMENSIONS ALLOW FOR CLEARANCE BETWEEN GRATE SECTIONS AND FRAME IN THE WIDTH DIMENSION ONLY.
- 3-TRIM THE FILLER TO ENSURE A TIGHT FIT IN THE TRAFFIC DIMENSION

SPECIFICATIONS:

GRATEDESIGN MODEL G-525DKU HAS OUR 100% POLYAMIDE FIBERS 80 D'TEX AND 40 D'TEX TUFTED NYLON CLASS 1 FIRE RATED. THEN ALTERNATES WITH A SCRAPER BAR. RAILS ARE MADE WITH 6063-T52 ALLOY RAILS. ARE 1-3/4" (44.5MM) DEEP AND, SPACED 1-1/8" (28.6MM) ON CENTER. WITH KEYLOCKS SPACED 3" (76.2MM) ON CENTER. FRAMES USED WITH THE G-525DKU ARE: TYPE F-1LEVEL BED; TYPE F-LANG LARGE ANGLE; TYPE F-2 DEEP PIT; TYPE F-2T THIN SLAB FRAMES WHICH ARE MADE OF ALUMINUM.

	<p>Arden Architectural Specialties, Inc. 9300 73rd Avenue North Brooklyn Park, MN 55428</p>
<p>MODEL NO. G-525DKU</p>	
<p>RELEASED DATE 1/5/2011</p>	<p>SHEET 1 OF 1</p>