

8

7

6

5

4

3

2

1

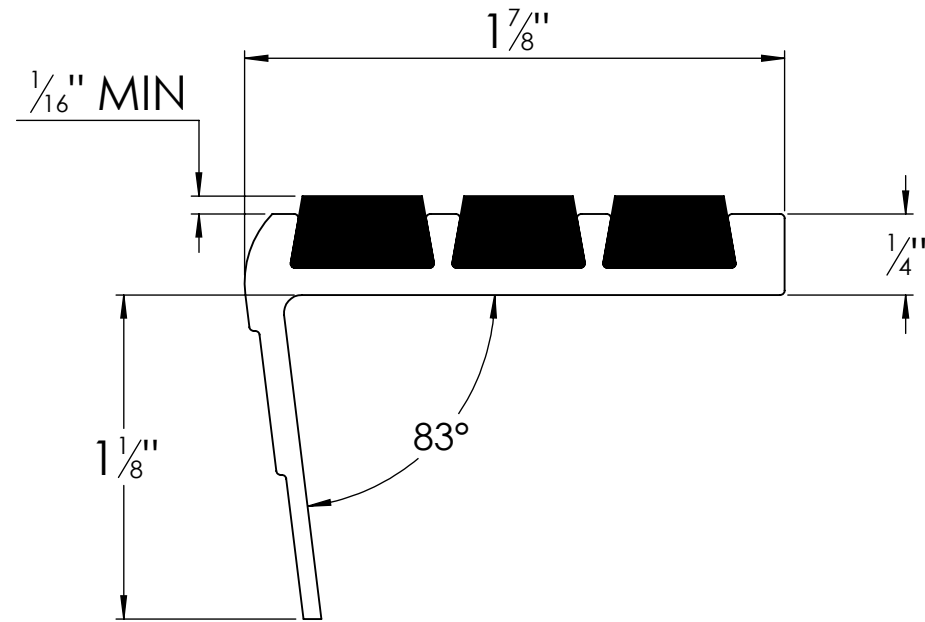

**MODEL A1.875D**

(SINGLE STAGE RIBBED ABRASIVE BARS)

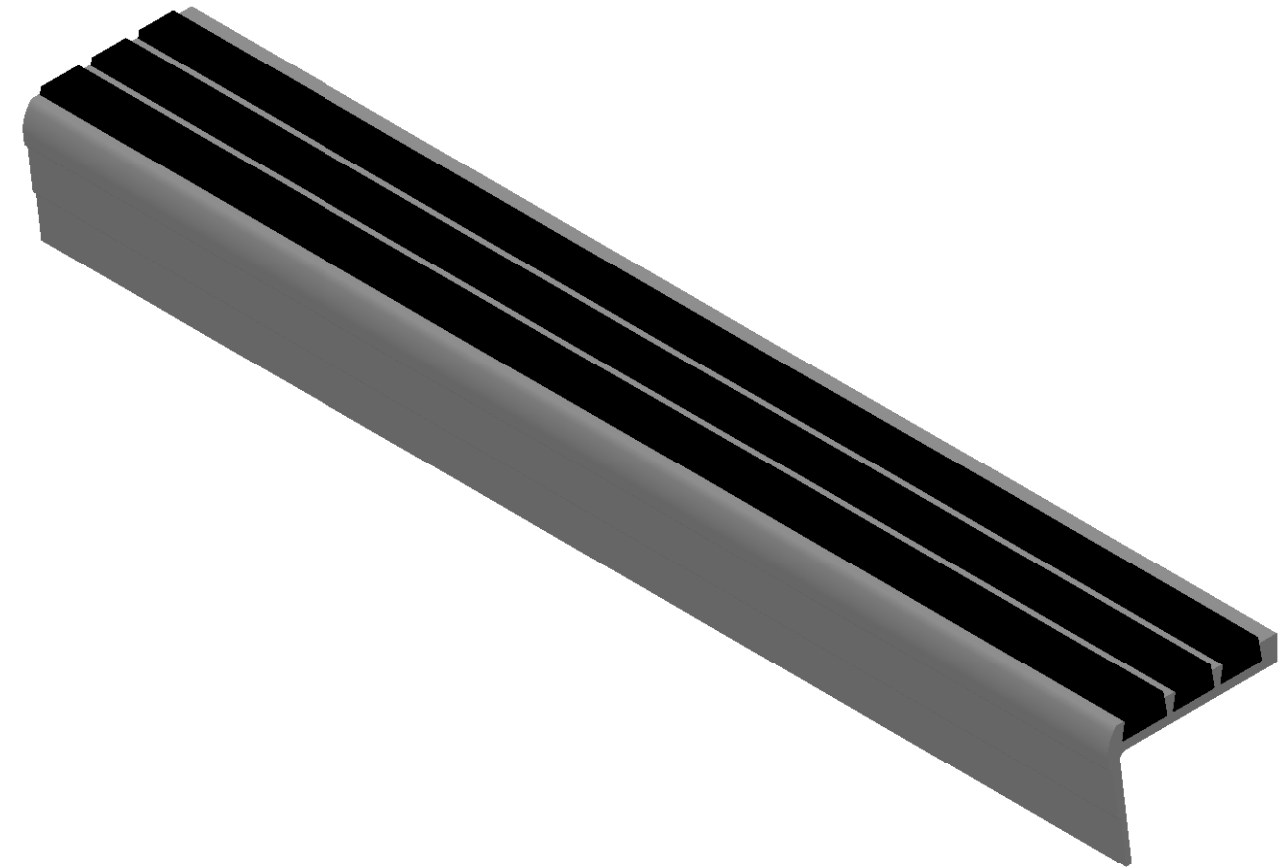

**SPECIFICATIONS:**

① **BASE:** HEAT TREATED EXTRUDED ALUMINUM ALLOY 6063 T-5

② **ABRASIVE:** ALUMINUM OXIDE SILICON CARBIDE GRANULES IN A UV PROTECTED, 2 PART EPOXY, LOCKED INTO EXTRUDED CHANNELS

3. **BASE FINISH:** MILL

4. **POURED CONCRETE STAIRS:** NOSING SHALL TERMINATE NO MORE THEN 3" FROM END OF STEPS

5. **CONCRETE FILLED STEEL PAN STAIRS:** NOSING SHALL BE FULL LENGTH OF STEPS, LESS 1/8" CLEARANCE

6. **COLOR:** BLACK (STANDARD), SAFETY YELLOW, GRAY, RED, BROWN, GREEN, BURGUNDY, BLUE, BUFF

- 7. **LENGTH:** 120" MAXIMUM (STANDARD)
- 8. **COUNTER SUNK HOLES** PRE-DRILLED FOR A #10 FASTENER SPACED 3" FROM ENDS AND APPROXIMATELY 12" TO 15" O.C.

LENGTH	QTY	COLOR

**BSTSB-A1.875D**

UNLESS OTHERWISE SPECIFIED: DIMENSIONS ARE IN INCHES		 <p><b>Babcock-Davis</b> <i>Always right there.</i> 9300 73rd Avenue North Brooklyn Park, MN 55428</p>		TITLE: V830, Stair Tread, Bar Ribbed Abrasive, Long Nose Angled, Drilled For Bolt In,	
MATERIAL 6063-T5	NAME DRAWN RELEASED	DATE 01/24/11 01/24/11	SIZE <b>B</b>	DWG. NO. <b>BSTSB-A1.875D</b>	REV <b>A</b>
FINISH: MILL			WEIGHT: 0.42 LB/FT		SHEET 1 OF 1

PROPRIETARY AND CONFIDENTIAL: THE INFORMATION CONTAINED IN THIS DRAWING IS THE SOLE PROPERTY OF BABCOCK-DAVIS. ANY REPRODUCTION IN PART OR AS A WHOLE WITHOUT THE WRITTEN PERMISSION OF BABCOCK-DAVIS IS PROHIBITED.

8

7

6

5

4

3

2

1