

CFR-42 INSULATED ROOF PANEL

# *Installation*

# GUIDE



# C O N T E N T S

INTRODUCTION.....	2
CUSTOMER RESPONSIBILITIES.....	3
SAFE ROOF ERECTION	
1. Erector's Responsibility.....	3
2. OSHA.....	3
3. Working with Roof Panels.....	4
CHECKING THE STRUCTURE	
1. Completed and Braced.....	6
2. Alignment.....	6
RECEIVING & HANDLING ROOF MATERIALS	
1. Unloading and lifting equipment.....	7
2. Material Inventory.....	7
3. Field Storage.....	7
4. Handling Panels.....	8
ROOF PANEL LAYOUT	
1. Sheeting Direction and Modularity.....	9
2. Layout & Checking for Coverage.....	9
3. Appearance Considerations.....	9
ROOF ERECTION BASICS	
1. Installation Drawings.....	10
2. Proper Tools.....	10
3. Weather Sealants.....	11
4. Vapor Sealants.....	12
5. Fasteners.....	13
6. Field Cutting.....	15
7. Surface Protection.....	16
8. Unspecified Materials.....	17
9. Inspection During Erection.....	17
ERECTION DETAILS	
1. Erection Details.....	18
2. Detail Index.....	19
3. Detail Drawings.....	20-67
4. Notes.....	68

## I N T R O D U C T I O N

The CFR-42 Roof System utilizes the proven thermal and structural performance of Metl-Span III foam panel technology, combined with the superior weathering performance of a standing seam roof, to provide the most effective roof system available today.

To ensure the ultimate performance and long service life of the CFR-42 roof, Metl-Span provides you the highest quality materials and the most comprehensive system of factory preparation, self alignment features and erection aids.

This Installation Guide provides you technical information and suggested erection procedures to help you understand and erect your CFR-42 roof with assured performance and erection efficiency.

This guide is intended to be used in conjunction with the project's installation drawings to help plan and organize the erection of the CFR-42 Roof System. The installation drawings govern specific part arrangement and identify the applicable roof conditions. This erection guide will help you identify parts, establish the erection sequence, demonstrate correct assembly, and point out any areas or procedures requiring special emphasis or attention.

This guide applies to the standard CFR-42 Roof System used on typical commercial and industrial applications. Cold Storage applications and non-standard application may require special details and instructions. Refer to the installation drawings or project specifications for the specific requirements.

In case of conflict between this erection guide and the installation drawings, the installation drawings will take precedence.

---

## CUSTOMER'S RESPONSIBILITY

The customer is responsible for ensuring that the CFR-42 Roof System is suitable for the purpose which it is to be used.

The customer is responsible for ensuring that the roof is erected in accordance with good engineering and construction practices and in accordance with the project's installation drawings and this guide.

The customer must take the responsibility for selecting a competent erector and must ensure that the work be performed by installers who are qualified and experienced in the proper installation of standing seam metal roofs and foam core panels.

Metl-Span does not guarantee and is not liable for the quality of erection, and is not responsible for roof defects that may be attributed to improper erection or the negligence of other parties.

Clarification concerning the CFR-42 roof installation should be directed to the Metl-Span Customer Service Manager. Contact the Metl-Span office: 1497 North Kealy, Lewisville, Texas 75057  
TEL: (972)221-6656 FAX: (972)436-7028 NET: [www.metl-span.com](http://www.metl-span.com)

## SAFE ROOF ERECTION

### **1. Erector's Responsibility:**

The roof system's erector is responsible for the safe execution of the roof erection.

These erection instructions are not intended to prescribe comprehensive safety procedures. If the erector cannot safely assemble the roof in accordance with these instructions, it is the responsibility of the erector to stop the work and contact Metl-Span to determine alternate assembly procedures.

### **2. OSHA:**

The Occupational Safety and Health Act (OSHA) has promulgated many regulations applicable to the erection of roof systems. These regulations, identified as Part 1926, Safety and Health Regulations for Construction, are available from any government book store. The objective of the OSHA standards is to protect the worker from injury or illness.

The OSHA regulations should be recognized as job site requirements and fully complied with. Failure to do so may result in substantial fines in the event of an OSHA inspection.

Safe installation practices may be further defined and made mandatory by state or local ordinances.

### **3. Working with Roof Panels:**

*A. Panel Weight* – the CFR-42 roof panels are relatively heavy. Proper lifting equipment and sufficient manpower will be required to handle and erect the panels without damage to the panels or injury to the workers.

*B. Crew Size* – the length of the individual roof panels should be considered when determining the crew size. It is recommended that, under normal conditions, there be a worker at each end of the panel, plus a worker at each 8' to 10' interval.

*C. Setting Panels on the Structure* – do not place bundles of panels on the roof structure without first verifying the structure will safely support the concentrated weight of the panel bundles and the weight of the erection crew and equipment. Some roof structures may require additional structural support.

*D. Safety Equipment* – the use of safety equipment is recommended at all times during the roof erection process. However, when using lanyards, ensure that the clasp, belt hooks and wire cables are covered in such a manner that they will not scratch the panel and flashing surfaces if accidentally dragged across the roof.

*E. Walking on Roof Panels* – an approved and safe walking platform should be used in high traffic areas to prevent the roof panel from being damaged by the personnel, material and equipment traffic.

Do not use a roof panel as a working platform. An unsecured panel can slide or even collapse under the weight of the workers and equipment. Do not stand on the end of unsupported (cantilevered) panels at the eave or ridge. Standing on the cantilever portion may result in panel upset or even collapse.

*F. Point Loads* – when properly supported by the structurals, panels are designed to support uniform loads which are evenly distributed over the panel surfaces. Point loads that occur in small or concentrated areas, such as by heavy equipment, ladder or platform feet, etc., may cause panel damage or even panel collapse and must be avoided.

*G. Slick Surfaces* – panel surfaces and structural surfaces are hard and non-absorbent causing them to be very slick when wet or covered with snow or ice. Sand and other loose materials can also cause slipping on these surfaces. Unpainted panel surfaces are often coated with an oil to accommodate the panel's fabrication process. Such oil can be extremely slick, especially during periods of light rain or dew.

Caution must be exercised to prevent slipping and falling, or even sliding off the roof. Non-slip footwear is a necessity and non-slip working platforms are recommended.

*H. Electric Conductance* – metal panels are excellent electrical conductors. A common cause of injury is the contact of metal panels with power lines during their handling and erection. The erection process must be routed to avoid accidental contact with high voltage power lines, services and equipment.

All tools and power cords must be properly insulated and grounded and the use of approved ground fault circuit breakers is recommended.

*I. Sharp Edges* – some edges of panels and flashing are razor sharp and can cause severe cuts if proper protective hand gear is not worn. Be careful not to injure others while moving panels and flashing.

*J. Wind* – do not attempt to move panels in strong winds. Wind pressure on a roof panel can easily cause the workers, carrying the panel, to lose balance and fall. Loose, wind blown panels are very dangerous and can cause severe injury and damage.

Secure stacks of panels with banding or tie-downs so wind will not blow the panels off the roof. Clamp individual unsecured panels to the roof structurals.



### 1. Completed and Braced:

Before placing materials and workers on the roof structure, it must be verified that the structure is designed to accommodate the material and erection loads as well as the design loads and it must be determined that the structure is complete and structurally sound with all structural connections and bracing in-place and secured.

Before starting the roof erection, the necessary roof framing members such as the eave and rake structurals and the endlap support structural, must be in place and secured.

### 2. Alignment:

Prior to installation, roof structurals should be checked for overall dimensions, square and level to plane. The roof structurals and adjacent structures must be checked to verify that the roof system can be installed without interference. Also, roof structurals nearest the panel endlaps, ridge or high eave should be checked for correct location to properly accommodate the roof system's components .

A. *Tolerances* – to assure the roof system's correct fit-up, the structure must be aligned within the following tolerances:

**Out of Square** – the roof system can accommodate  $\pm 1/4$ " of sawtooth of the roof panel ends at the eave, ridge and endlaps.

**Structure Length** – the roof system is designed to accommodate  $\pm 2$ " of overall structure length error, or  $\pm 1$ " of error at each rake.

**Structure Width** – the roof system is designed to accommodate  $\pm 1$ " of overall structure width error, or  $\pm 1/2$ " of error at each eave.

**Level** – the roof system is designed to accommodate the following maximum deviations of the roof structurals from the theoretical roof plane:  $\pm 1/8$ " in any 5' length,  $\pm 1/4$ " in any 20' length and  $\pm 1/2$ " over the entire roof area.

B. *Aesthetic Acceptance* – although these structure alignment tolerances will allow for reasonable roof component fit-up and ease of installation, the extremes of these tolerances may be aesthetically objectionable and should be confirmed with the customer before starting the roof installation.

C. *Corrections* – any structure alignment error which exceeds the above stated tolerances must be corrected before roof erection can begin. If it is decided that the structure alignment errors cannot be corrected, modified or alternate roof details may have to be developed. The modified details may require additional materials, modified parts (with additional cost, fabrication and delivery time) and additional installation time. Metl-Span cannot assure the performance of such modifications.

### **1. Unloading and Lifting Equipment:**

Forklifts or hoisting equipment are necessary to unload and position the panel bundles and accessory crates for site storage and installation. The equipment must have sufficient capacity and reach to safely lift and place the material where it is required for efficient erection.

If hoisting equipment is used to lift the panel bundles, sufficient pick up points must be used to prevent bending damage of the panels and spreader bars or anti-pinch boards must be used to prevent pinching of the top and bottom panels in the bundle. It is recommended that slings be of 6" minimum width and bearing boards or pads be used to prevent crushing of the bottom panel.

**The forks or slings must be carefully positioned to avoid damaging the bottom panel of the panel bundles.**

### **2. Material Inventory:**

Your material is carefully inspected and crated before leaving the plant. The material is accepted by the transportation company as being complete and in satisfactory condition. It is the transportation company's responsibility to deliver the shipment intact and in satisfactory condition. It is the consignee's responsibility to inspect the shipment for damage and shortages when it is delivered.

Conducting a material inventory at the time of delivery is essential. By conducting the materials inventory, the erector is able to identify any material shortage or damage and minimize later erection delays caused by such shortages or damaged materials.

It is most important that any shortages or damage of the delivered materials be noted at once and clearly marked on the bill of lading before signature of acceptance. Notify Metl-Span immediately of any conflicts. Metl-Span cannot be responsible for shortages or damaged materials unless they are noted on the bill of lading.

In the case of packaged components (such as clips, fasteners and sealants, etc.), the quantities are marked on their container and should be checked against the bill of materials. Metl-Span must be notified of any such shortages or concealed damage within 15 days of delivery.

### **3. Field Storage:**

Upon acceptance of the shipment, the customer or his representative is responsible for proper handling, storage and security of the roof materials. Metl-Span is not liable for damage or loss of materials at the job site.

The roof panel bundles should be stored on the job site as follows:

- Store panels in a protected area, out of standing water and drifting snow, etc.



- Elevate panels with blocking to allow air circulation under the bundle. The blocking should be uniformly spaced at 10' intervals.
- Arrange the blocking so that the panels are sloped. The slope should be steep enough to cause drainage of any accumulated moisture from the panel surfaces.
- To allow air circulation around and between the panels, slit the bundle's protective wrapping along the bottom edge of the bundle. To prevent the wrapping from blowing off the bundle, cut intermittent slits rather than a continuous slit.
- Inspect panels daily for moisture accumulation. If panel bundles contain moisture, the panels should be dried and restacked.

Trim and accessories should be stored in a secure area and protected from damage, weather, and theft. Fasteners, sealants, closures, etc. should be stored out of the weather and protected from contamination. Refer to labels on sealant packages for information concerning shelf life and instructions for proper use.

#### **4. Handling Panels:**

When moving panel bundles, extreme caution should be taken to prevent damage to the panel edges.

Be sure to set panel bundles on the roof in the proper orientation for the erection sequence. On steep roofs, provisions should be taken to prevent panels and panel crates from sliding off the roof.

To manually handle individual panels, the panels must be lifted by lifting on the underside face. Attempting to lift the panel by only the top face or standing seam may cause separation of the face from the foam core. To prevent bending damage of the panel, the lifting points should be no more than 8' to 10' apart. Do not attempt to lift long panels by the ends only.

When setting the panel on its edge to turn it over, soft wood or foam bearing pads must be set under the panel edge to prevent scuffing and crushing damage.

To lift the panels to the roof, suitable hoisting equipment with a vacuum lift or multiple sling lift is recommended. The vacuum heads or slings must be appropriately spaced to prevent panel bending damage. The hoisting equipment must have sufficient capacity and reach to safely set the panels into position on the roof framing.

### 1. Sheeting Direction and Modularity:

A. *Sheeting Direction* – the CFR-42 roof panels must be installed from left to right, when looking from the eave towards the ridge. The recommended installation sequence is to complete each panel run from eave to ridge before starting the next panel run. This sequence will help ensure straight runs and proper endlap assembly.

B. *Panel Modularity* – during installation of the roof, consideration must be made for maintaining panel modularity (side joint to side joint coverage width). By maintaining panel modularity, proper roof coverage can be obtained and the standard perimeter parts will fit properly without necessity of field modifications or reordering parts, etc.

The standard CFR-42 panels have a coverage width of 42" (3'-6"). The information within this guide specifies the installation of the standard 42" width panels.

For some applications, panels may be provided with optional coverage widths of 30" or 36". Refer to the project's installation drawings for the specified panel widths and installation requirements.

C. *Module Tolerance* – for proper fit-up of the panel sidelaps, endlaps and closures, the panel modularity must be held to the theoretical panel width  $\pm 1/8"$ .

D. *Accumulated Tolerance* – accumulated coverage tolerance (start panel to finish panel) is determined by the ability to keep the panels parallel and to correctly fit and assemble the finish rake condition. If the roof has conditions such as fixed location penetrations, parapets, fire walls, etc., the accumulated panel coverage may require tighter tolerances for proper fit-up and weather tightness of the roof system.

### 2. Layout & Checking for Coverage:

A. *General* – recommended for all roofs, but a must for large or complex roofs, is to make a layout of the actual (field measured) structure so that the starting and finish roof panel dimensions can be laid out to accommodate any structural misalignments.

B. *Starting Dimension* – the starting dimension will be used to layout the field cutting of the starting panel and to align the starting panel on the roof structurals. After the starting panel is erected, its seam will be the reference line for checking accumulated panel coverage.

C. *Checking Coverage* – panel coverage is always checked at the eave, ridge, and end splices so that non-parallel seam (or dogleg) conditions can be detected and corrected before they become objectionable. The coverage check should be done with a measuring tape held taut and measured to the same side of the seam and always parallel to the eave to prevent any measuring error. Every four to six panel runs should be checked for panel modularity.

D. *Correction of Coverage* – If the panels are off module, they should be corrected by equal adjustments of the next four to six panel runs. Do not attempt to adjust the coverage by more than  $+ 1/8"$  and  $- 1/16"$  per panel.

### 3. Appearance Considerations:

Although the roof panels can be erected within a reasonably liberal coverage tolerance, visible conditions such as: non-parallel panel seams, dogleg of the panel seam at the endlaps, tapered finish panel width and mismatch of panel seams across the ridge, may be objectionable and should be confirmed with the customer before continuing roof erection.

### 1. Installation Drawings:

Ensure that the installation drawings are available at the job site and have been reviewed for differences with the actual job conditions and differences with this erection guide. Also, confirm that the drawings are the latest issue with the latest revisions and additions.

### 2. Proper Tools:

Before starting panel installation, be sure that the proper equipment and tools are on hand. The basic tools required for installing the CFR-42 Roof System are standard for the metal construction industry.

The tools must be in good operating condition and operators should adhere to safety precautions at all times. Improperly operating tools, too few tools, inadequate power source, or other equipment deficiencies slow down the installation process. The cost of inefficient labor practices is usually greater than the cost of providing good equipment.

The following special tools are necessary for erection of the CFR-42 Roof System:

*A. Rib Clamps* – the CFR-42 Rib Clamps are required to pull together the roof panel sidelaps. Sufficient clamps should be available for use at the panel ends and at each 10' panel length interval.

*B. Seam Clamp* – the CFR-42 Seam Clamps are required to pull together the roof panel seam at the endlaps. During cold weather, the seam clamp helps compress the endlap's seam sealant prior to the seaming operation.

*C. Hand Seamer* – the CFR-42 Hand Seamer is required to crimp the panel clips to the roof panel and to start and finish the roof panel seams. The hand seamer can be used to close the entire seam in cases where it is impractical to use the motor seamer.

The seam clamps, rib clamps and hand seamer are specially designed for the CFR-42 roof and are available for lease or purchase only from Metl-Span. Do not attempt to use other tools which may damage the panels or result in panel performance failure.

*D. Motor Seamer* – the CFR-42 motor seamer is required to close the roof panel seams. The seamer's motor requires a 20 amp, 120 Volt, AC power supply. The power cords must be of sufficient size to provide a full 20 amp to the motor without power drop.

The motor seamer is specially designed for the CFR-42 roof and is available for lease only from Metl-Span.

*E. Endlap Assembly Gauge* – the CFR endlap assembly gauge is required to help assure the proper positioning of the endlap sealant and endlap fasteners.

The endlap assembly gauge is provided with the CFR roof materials.

### **3. Weather Sealants:**

*A. General* – the proper application of the roof system's sealants (and fasteners) is usually the most critical factor effecting the roof's weather tight performance. It is the erector's responsibility to understand and ensure that the correct sealants are used and that they are applied in the proper manner and condition. This includes understanding the function and proper application of the sealant pigtails.

*B. Temperature Effects* – temperature extremes must be considered during erection of the roof due to the sensitivity of sealants. The recommended erection temperature range is 20° F to 120° F. At colder temperatures, the sealant stiffens resulting in loss of adhesion and compressibility. At hotter temperatures, the sealant becomes too soft for practical handling. On cold but sunny days, the panel's surface may become warm enough to accept the application of a heated sealant even though the air temperature is below 20°.

When overnight temperatures fall below freezing, the sealant should be stored in a heated room so it will be warm enough to use the following day. On hot days, the sealant cartons should be stored off the roof in a cool and shaded area, and sealant rolls on the roof should be kept shaded until actually used.

*C. Contamination* -- to assure proper adhesion and sealing, the sealant must have complete contact with the adjoining surfaces. Contaminants such as water, oil, dirt and dust prevent such contact. The panel and flashing surfaces must be dry and thoroughly cleaned of all contaminants. The sealant must also be free of contamination or distortion of its profile.

Before applying the sealant, check that it is not contaminated, torn or flattened. Do not use contaminated or damaged sealant.

During cool and/or humid weather, condensation or light mist can accumulate on the panel, flashing and sealant surfaces and not be easily noticed. It is important that the sealants always be kept under protective cover and that the panel and flashing surfaces be wiped dry immediately before installation.

Tape sealant is provided with a paper backing to reduce contamination. To protect the sealant during erection, leave the paper on the sealant until the final assembly. When it is time to remove the paper, check that the paper is completely removed. Remaining strips of the paper will prevent adhesion of the sealant to the adjacent surfaces.

*D. Alignment* – the tape sealants paper backing is specially designed to act as an alignment guide for the proper placement of the sealant. When applying the sealant, use the edge of the paper to guide the sealant as instructed in the erection guide details.

*E. Compression* – to assure proper adhesion and seal, the tape sealant must be compressed between the panel or flashing surfaces with firm and uniform pressure. In most cases, the required pressure is applied by the clamping action of screws pulling the adjoining surfaces together.

During cold weather, the fasteners must be tightened slowly to allow the sealant time to uniformly compress. If the fasteners are tightened too fast, the fastener may strip out before the sealant is compressed, or the panel or flashing may deform in the immediate area of the fastener, leaving the rest of the sealant insufficiently compressed.

In very cold weather, it is recommended that the fasteners be tightened slowly and only tight enough that the sealant is in full contact with the panel or flashing. Then, on the next sunny day, complete the tightening process after the sun warms the panel and flashing surfaces.

*F. Inside Corners* – an inside corner, such as where the panel flat meets a standing rib, is usually the most critical area to seal. Contaminants often accumulate in the corners and careful attention is required to be sure that the corners are wiped completely clean.

It is a common error for the erector to bridge (dogleg) the sealant across the inside corners. When the lapping panel or flashing is pushed into place, the bridged sealant is stretched and thinned. The sealant may then be too thin to adequately seal this critical area. When tape sealant is applied at an inside corner, it is recommended that the sealant be folded back on itself, then push the sealant fold into the corner.

#### **4. Vapor Sealant:**

*A. General* – because of the CFR-42 roof's exceptional thermal efficiency and the resulting greater vapor pressure differentials, the proper application of the vapor sealants is most critical to prevent condensation from occurring within the panel joints and perimeter assemblies.

On the typical commercial and industrial buildings, the vapor sealants are specified at the exterior and interior junctions of the roofs joints and perimeter assemblies. In most cases, the weather sealant serves the function of the exterior vapor sealant.

On the typical cold storage buildings, most freezer rooms and some cooler rooms will require the vapor sealant only at the warm side (exterior) and not at the cold side (interior) junctions of the roofs joints and perimeter assemblies. Because of the even greater vapor pressure differentials occurring within cold storage buildings, auxillary vapor seal provisions may be required at the exterior junctions of the perimeter assemblies.

On buildings with multiple functions, the vapor sealant requirements may vary between different rooms or areas.

The information within this installation guide specifies the vapor sealant applications for typical commercial and industrial buildings. For cold-storage and non-standard applications, refer to the installation drawings or project specifications for the specified vapor sealant requirements.

*B. Perimeter Conditions* – at the perimeter conditions, the roof panel edge is normally sealed to the top surface of the perimeter structural or flashing. It is the erector's responsibility to ensure that the perimeter structural or flashing joints are sealed vapor tight and provide a proper surface to receive the roof panel's vapor sealants.

*C. Bead Size* – apply the vapor sealant in a large enough bead to fully seal the panel's Mesa profile at the perimeter conditions and a ¼" bead to fully seal the panel's tongue and groove joint at the sidelaps. Do not apply so much sealant, that it spills over onto the visible surfaces.

## **5. Fasteners:**

*A. General* – the proper application of the roof's fasteners is usually the most critical factor effecting the roof's wind resistance and is equally critical to the roof's weather tight performance. It is the erector's responsibility to assure that the correct fasteners are used and are installed in the proper manner.

*B. Screw Gun* – use torque control screw guns for driving self-drilling and self-tapping screws. High amperage guns (4 to 7 AMP) are required to achieve the proper torque for secure fastening.

*C. Sockets & Bits* – use good quality sockets and bits. Good fitting sockets and bits reduce wobble and stripping of the screw heads, especially the alloy heads. They also minimize objectionable paint chipping and scuffing on colored screws and minimize damage to the protective coating on unpainted screws.



Magnetic sockets collect drill shavings which will build up and eventually prevent the socket from seating properly on the screw heads. One method of removing the drill shavings is to roll up a ball of tape sealant and push the socket into the sealant. When the socket is removed from the sealant, most of the drill shavings will remain embedded in the sealant thereby cleaning the socket. This process should be repeated as often as needed to keep the socket clear of drill shavings.

*C. Extensions* – Because of the roof panel's thickness, socket and bit extensions are recommended for installing the panel clip screws. With the extension, the screw can be driven straight down without tilting the screw gun to clear the panel or clip. Since extensions are slow to wear out, it is usually more cost effective to purchase extensions and good quality sockets and bits rather than purchase sockets and bits with built-in extensions.

*D. Drill Bits* – self tapping screws will require pre-drilled holes. Providing the correct size hole is most critical to the fasteners structural performance. See the following chart for the proper drill bit size required for the specific roof structural thickness. Caution: the eave, rake and roof structurals are often of different thicknesses and may require different size drill bits.

THICKNESS OF STEEL	SIZE OF DRILL	TYPE OF SCREW
18 GAUGE	3/16" DRILL	B,BP, AB,A
16 GAUGE	#9 DRILL	B,BP, AB,A
14 GAUGE	#9 DRILL	B,BP, AB,A
12 GAUGE	#3 DRILL	B,BP
11 GAUGE	#2 DRILL	B,BP
OVER 11 GAUGE THRU 3/8"	#1 DRILL	B,BP
OVER 3/8" THICKNESS	.231 DRILL	B,BP

Because of the roof panel's thickness, the drill bits must be long enough to allow drilling without tilting to clear the panel and clip.

*E. Installation* – before starting the screw, the materials to be joined must be pressed together with foot or hand pressure. The pressure must be maintained until the screw has drilled through all the materials and the threads have engaged.

Most self-drilling screws require 20 pounds of pressure to maintain the drilling action and to start the thread cutting action. Also, applying such pressure before starting the screw gun will usually prevent tip walking or wandering. If too little pressure is applied, the drill point may not cut into the metal and the point will heat up and become dull. If the

pressure is too heavy, the bottom material may be deflected away, causing a stand-off condition, or the drill tip may be broken or split.

For proper seating of the fastener's sealing washer, the panel or flashing surface must be clean and drill shavings must be removed from under washers before seating. The fastener must be driven perpendicular to the panel surface so that the washer can seat level without warping or cupping.

Do not over drive screws. Over driving can strip the threads and/or damage the sealing washer. When possible, use drivers with torque control set to function properly for the combination of fastener size, hole size, and material thickness.

The fastener should be driven tight enough to uniformly compress the washer but not so tight that the washer splits or rolls out from under the metal backer. The recommended procedure is to tighten the fastener until the sealing washer just starts to visually bulge from under the metal backer.

As a good installation practice, all roof installers should carry approved oversized screws. Upon stripping or breaking a screw, the screw must be immediately removed and replaced with the appropriate oversized screw. Do not defer the screw replacement to be remembered and fixed later or to be found by the clean-up crew. The majority of such screws will be overlooked until the customer complains of leakage.

## **6. Field Cutting:**

*A. Cutting Panels* – the panels are easily cut with circular saws or reciprocating saws using proper metal cutting blades. If the saw cannot cut through the entire panel thickness or if shears are used, cut each panel face and use a thin knife to cut through the remaining foam.

Be sure to properly support the panel during the cutting operation to prevent delamination or buckling of the panel. Carefully cut the standing ribs to prevent bending the rib or delaminating the rib from the panel's foam core.

*B. Abrasive Saw Problems* – abrasive saws (circular saws with friction disks) are not recommended for cutting roof panels or flashing. Abrasive saws create high heat which may burn away the protective cladding from the panel edges causing the edge to rust. Also, abrasive sawing emits fine, hot steel particles which will accumulate on the panel and flashing surfaces where they rust and can cause staining and rusting of those surfaces. Rust caused by abrasive saw damage or abrasive sawing particles are excluded from the material warranty claims.

*C. Cutting Flashing* – It is recommended that flashing be cut with shears to provide a clean, undamaged cut. On shear cut edges, the protective cladding extends to the edge of the cut and is often wiped over the edge to further protect the base metal.

When field cutting complex shapes, it is usually easier to cut out a 1" wide strip using both left and right hand shears. The 1" cut-out provides the clearance to make smooth cuts and the clearance to work the shears around tight corners.

Whenever possible, fit the material so that the factory cut edge is exposed and the field cut edge is covered.

*D. Layout and Marking* - when marking the panels for cutting, avoid marking the panels in a manner which will leave marks or stains on the visible surfaces. Use chalk or washable felt tip markers.

Do not use graphite pencils on unpainted panel surfaces, the graphite can cause rusting of the surface.

When making repetitive cuts (such as cutting panels at a hip or valley) it is recommended that a template be made from a piece of drop-off panel or flashing to provide fast and accurate marking for the field cut. When using panel material for the template, cut off the top portion of the panel ribs so that the template is easily laid onto the panel being marked.

## **7. Surface Protection:**

*A. Surface Damage* – damaged roof panel and flashing surfaces are subject to corrosion and performance problems and may void the material warranties. Assure that the surfaces are not being subjected to abusive conditions such as: careless handling of panels and flashing, excessive roof traffic, abrasive or contaminated footwear, rough handling of materials, tools and equipment, and contact with abrasive materials or residue, etc.

*B. Iron Objects* – ensure that the panel and flashing surfaces are not being subjected to exposed iron or steel objects and materials left on the roof such as: tools, material drop-off, fasteners, wire and banding, cutting or drilling chips, etc. In the process of rusting, these materials will absorb the panel's protective coating, thus leaving the panels exposed to rusting.

*C. Wet Conditions* – ensure that the panels and flashing are not being subjected to long term wet conditions such as: standing water or consistent sources of steam, spray and dripping moisture, wet debris, wet insulation or other moisture holding materials.

*D. Corrosive Materials* – ensure that the panels and flashing are not subjected to direct contact or runoff from corrosive materials such as: copper pipes and flashing, uncured cement, treated lumber anti-icing chemicals, strong solvents or other corrosive materials.

### **8. Unspecified Materials:**

Use of the wrong materials may cause installation and performance problems and may void the material warranties. All installed roof system materials, especially sealants and fasteners, must be those which are provided by Metl-Span or are specified on the project's installation drawings and are used only as specified on the installation drawings and this erection guide.

Metl-Span cannot be responsible for the performance of roof materials which are not provided, specified or approved by Metl-Span.

### **9. Inspection During Erection:**

During the roof erection, all areas of the roof system assembly must be frequently inspected to ensure that the roof system is being erected in a proper and weather tight manner and in accordance with the installation drawings and this erection guide.

Failure to assemble the roof system correctly will result in roof performance problems which may require costly corrective work, roof replacement, and performance and damage claims, etc. Also, incorrect installation may void the material warranties.

## ERECTION DETAILS

*A. General* – the following details provide graphic illustration of the roof assembly steps. The purpose is to provide suggestions to the erector for the proper and efficient assembly of the roof system.

*B. Installation Drawings* – study the project's installation drawings to determine the roof conditions on your project and to determine any differences with these details. If differences exist, the installation drawings have precedence.

*C. Specific Details* – because of the many variations in roof conditions, it is important that you review all of the erection details to select and isolate the specific details required for your project.

*D. Detail Sequence* – these details are arranged in a step-by-step sequence for the standard roof conditions. Following this sequence ensures correct assembly and ensures that the area to be worked on will be readily accessible for the next assembly step. Do not short-cut this sequence without careful consideration of the possibility of incorrect or omitted assembly and the resulting corrective rework.

*E. Detail Orientation* – to minimize confusion, the details are typically oriented so that the view is from eave to ridge, with the starting rake at the left and finish rake at the right. At the beginning of each erection section, a general overview detail is provided to help the understanding of the roof assembly orientation.

*F. Weather Tightness* – to help ensure the roof's weather tight assembly, the details emphasize proper fit-up, sealing and fastening. The type and size of fasteners and sealants are specified for each condition. Be sure that these critical instructions are reviewed often and the roof assembly is checked at each assembly step.

## DETAIL INDEX

TITLE	AUTOCAD FILE NO.	PAGE NO.
STANDARD PANEL DESCRIPTION	C450.600.1	20
STANDARD FASTENERS DESCRIPTION	C450.601.1	21
STANDARD SEALANTS DESCRIPTION	C450.602.1	22
STANDARD CLOSURES DESCRIPTION	C450.603.1	23
STANDARD GUTTER PARTS DESCRIPTION	C450.604.1	24
CFR PANEL TOOLS DESCRIPTION	C450.620.1	25
<b>SECTION 1</b>		
ROOF PANEL INSTALLATION	C450.605	26
INTERIOR RIDGE FLASHING INSTALLATION	C450.606.1	27
STARTING DIMENSION LAYOUT	C450.607	28
PERIMETER VAPOR SEAL APPLICATION	C450.608	29
STARTING PANEL INSTALLATION	C450.609	30
PANEL CLIP INSTALLATION	C450.610	31
SEAM & VAPOR SEALANT APPLICATION	C450.611	32
SEALANT PIGTAIL APPLICATION	C450.612.1	33
PANEL SIDELAP ENGAGEMENT	C450.613	34
PANEL INSTALLATION	C450.614	35
CHECKING PANEL COVERAGE	C450.615	36
FINISH PANEL INSTALLATION	C450.616	37
<b>SECTION 2</b>		
ENDLAP ASSEMBLY	C450.617	38
ENDLAP VAPOR SEAL APPLICATION	C450.618	39
DOWNSLOPE PANEL INSTALLATION	C450.619.1	40
ENDLAP SEALANT APPLICATION	C450.621.1	41
ENDLAP SEALANT PLACEMENT	C450.622.1	42
UPSLOPE PANEL ENGAGEMENT	C450.623.1	43
UPSLOPE PANEL INSTALLATION	C450.624	44
ENDLAP FASTENER APPLICATION	C450.625.1	45
ENDLAP PIGTAIL/PANEL CLIP INSTALLATION	C450.626	46
SEAM & VAPOR SEALANT APPLICATION	C450.627	47
START/FINISH PANEL PIGTAIL APPLICATION	C450.628	48
<b>SECTION 3</b>		
RAKE & RIDGE CLOSURES INSTALLATION	C450.629	49
RAKE CLOSURE SEALANT APPLICATION	C450.630	50
RAKE CLOSURE INSTALLATION	C450.631	51
RAKE CLOSURE SPLICE ASSEMBLY	C450.632	52
RIDGE CLOSURE PREPARATION	C450.633	53
RIDGE CLOSURE SEALANT APPLICATION	C450.634	54
RIDGE CLOSURE INSTALLATION	C450.635	55
TYPICAL TRIM & FLASHING INSTALLATION	C450.636	56
<b>SECTION 4</b>		
TRIM & FLASHING INSTALLATION	C450.637	57
RAKE FLASHING INSTALLATION	C450.638	58
EAVE TRIM INSTALLATION	C450.639	59
EAVE GUTTER INSTALLATION	C450.640.1	60
GUTTER END & SPLICE ASSEMBLIES	C450.641	61
CORNER & PEAK CAP ASSEMBLIES	C450.642	62
<b>SECTION 5</b>		
TRANSITION FLASHING INSTALLATION	C450.643	63
HIGH SIDE TRANSITION FLASHING INSTALL.	C450.644	64
RAKE TRANSITION FLASHING INSTALL.	C450.645	65
REGLET INSTALLATION	C450.646	66
TYPICAL ROOF PANEL SEAMING	C450.647	67



# CFR-42 ROOF PANEL

C450.600.1

## STANDARD PANEL DESCRIPTION

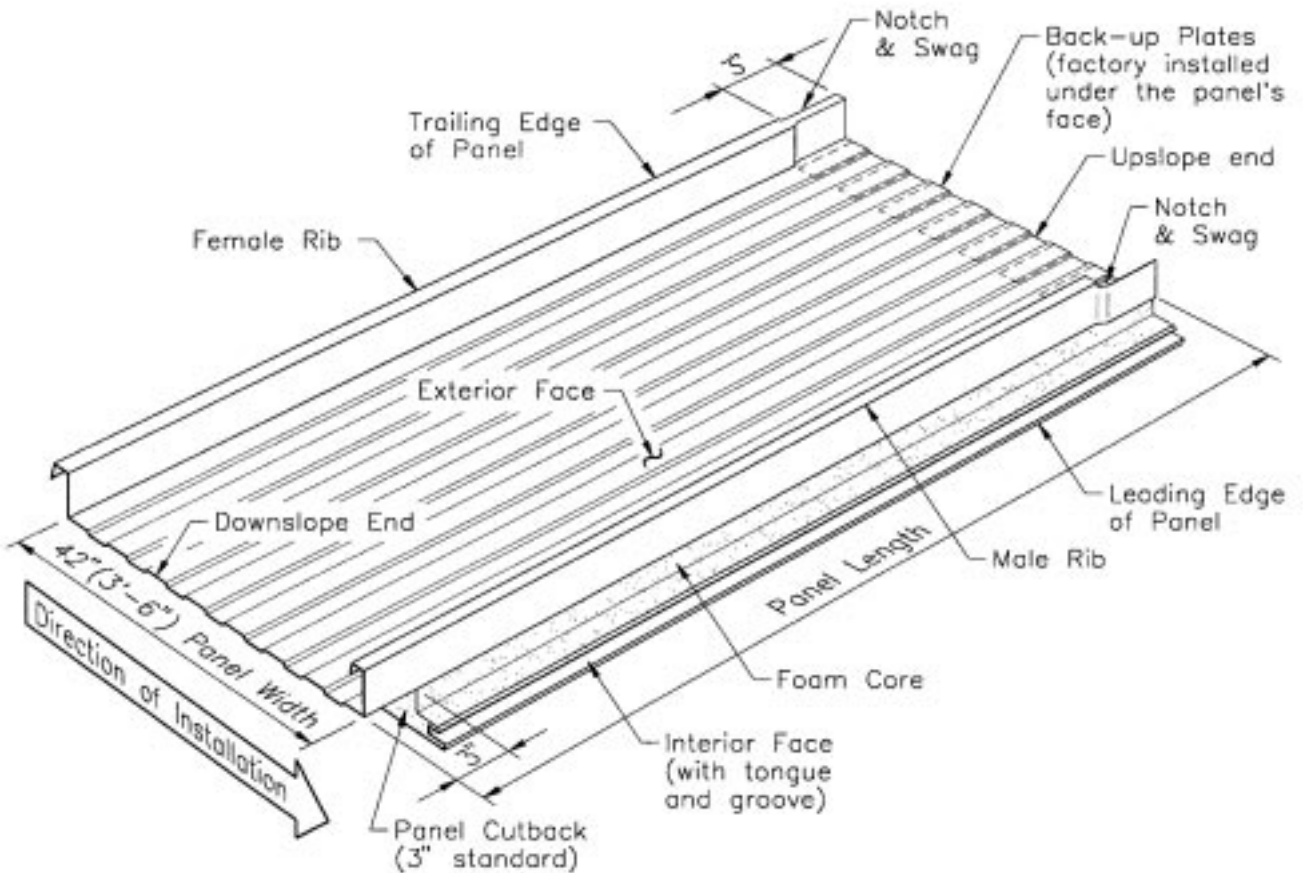
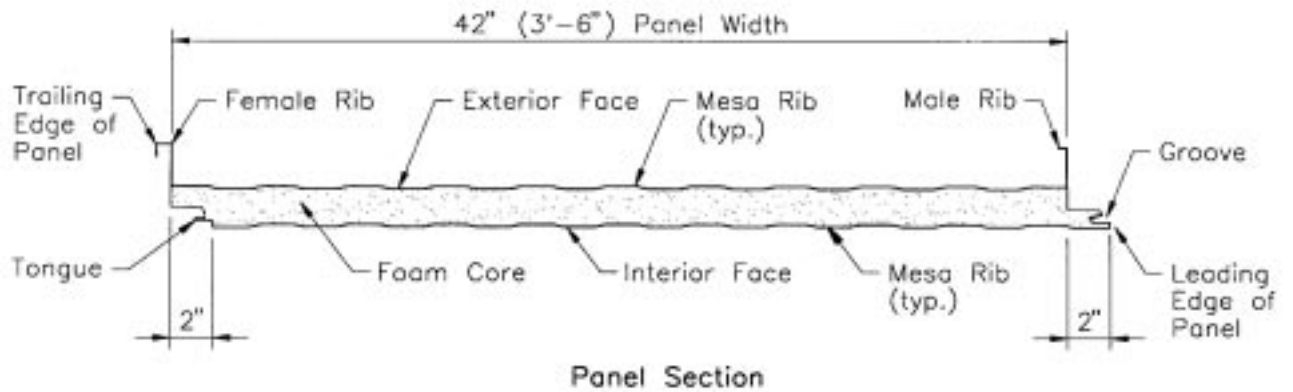

**Note:** All standard roof panels are the same except for the panel length variations. Refer to the job's Installation drawings for location of the specific length panels.

CFR-42 ROOF PANEL

C450.601.1

STANDARD FASTENERS DESCRIPTION

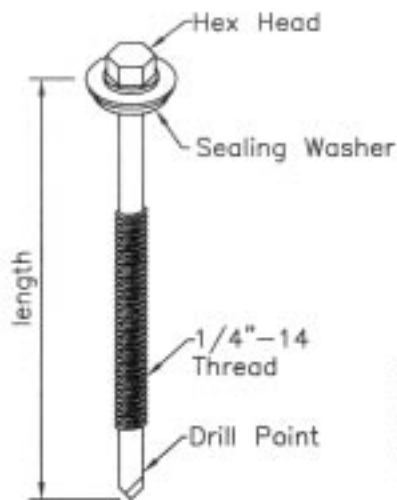

**Thru-Panel Fastener**  
(length varies with panel thickness)  
Part No. - length  
1124 PNC - 3"  
1132 PNC - 4"  
1140 PNC - 5"  
1164 PNC - 8"

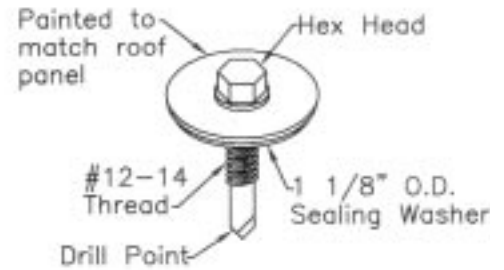

**Endlap Fastener**  
Part No. 1010 S##

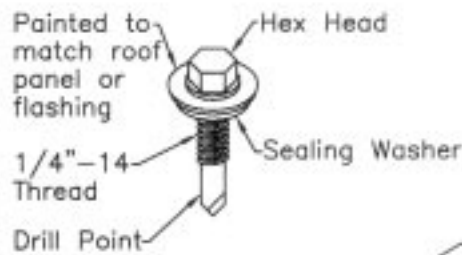

**Flashing Fastener**  
Part No. 1007 P##

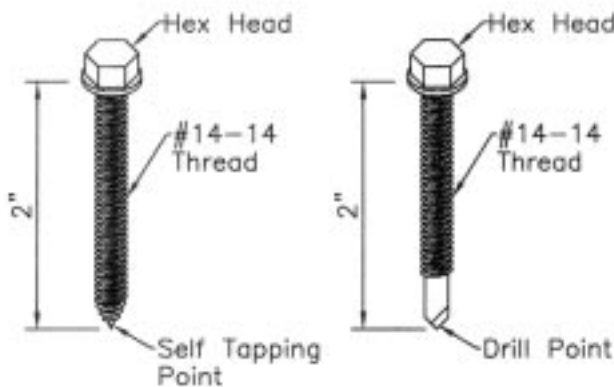

**Clip Fastener**  
(Self Tapping)  
Part No. 1816 PNC

**Clip Fastener**  
(Self Drilling)  
Part No. 1616 PNC

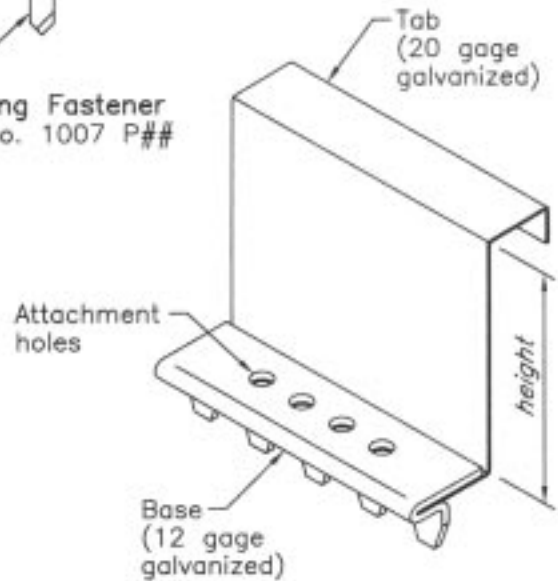

**Panel Clip**  
(height varies with panel thickness)  
Part No.- height  
4102 GNC - 2"  
4125 GNC - 2.5"  
4103 GNC - 3"  
4104 GNC - 4"  
4105 GNC - 5"  
4106 GNC - 6"

Note: The Thru-Panel and Clip Fasteners may vary per roof structural materials. Refer to the job's Installation Drawings for specific fastener requirements.

CFR-42 ROOF PANEL

C450.602.1

STANDARD SEALANTS DESCRIPTION

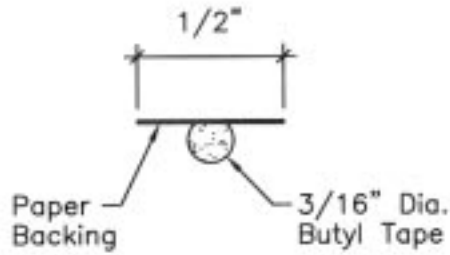

Clip Sealant Section  
Part No. 7401 BGR

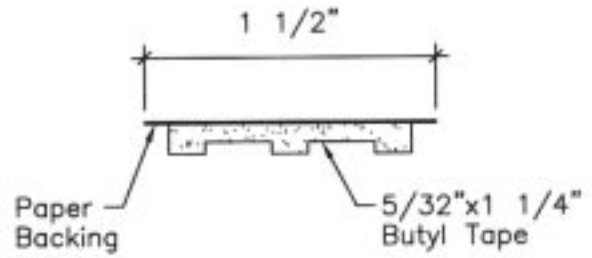

Endlap Sealant Section  
Part No. 7403 BGR

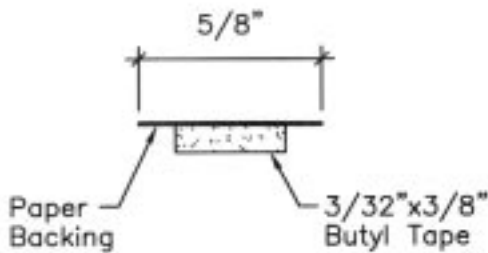

Seam Sealant Section  
Part No. 7404 BGR

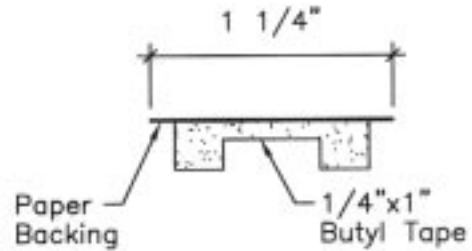

Flashing Sealant Section  
Part No. 7405 BGR

Note: Tape sealants provided in rolls.

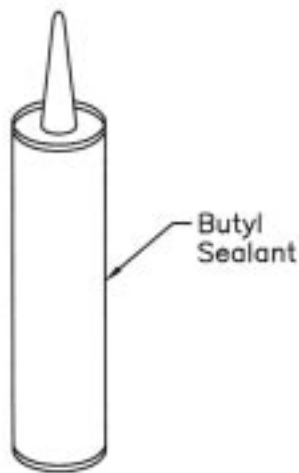

Vapor Seal Caulk  
Part No. 7100 BWH

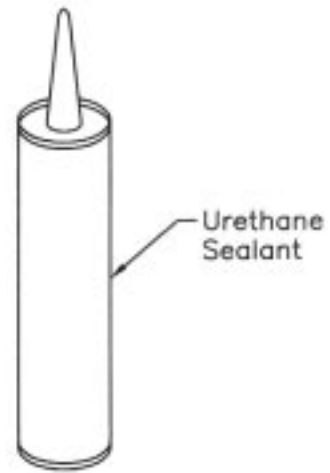

Flashing Caulk  
Part No. 7200 UWH

Note: Caulk provided in 1/10 gal. (10.5 oz.) tubes.

CFR-42 ROOF PANEL

C450.603.1

STANDARD CLOSURES DESCRIPTION

Ridge Closure			
Part No.	Panel	Width	Color
7942	GPW	42"	White
7942	GST	42"	Stone
7942	GBK	42"	Black
7936	GPW	36"	White
7936	GST	36"	Stone
7936	GBK	36"	Black

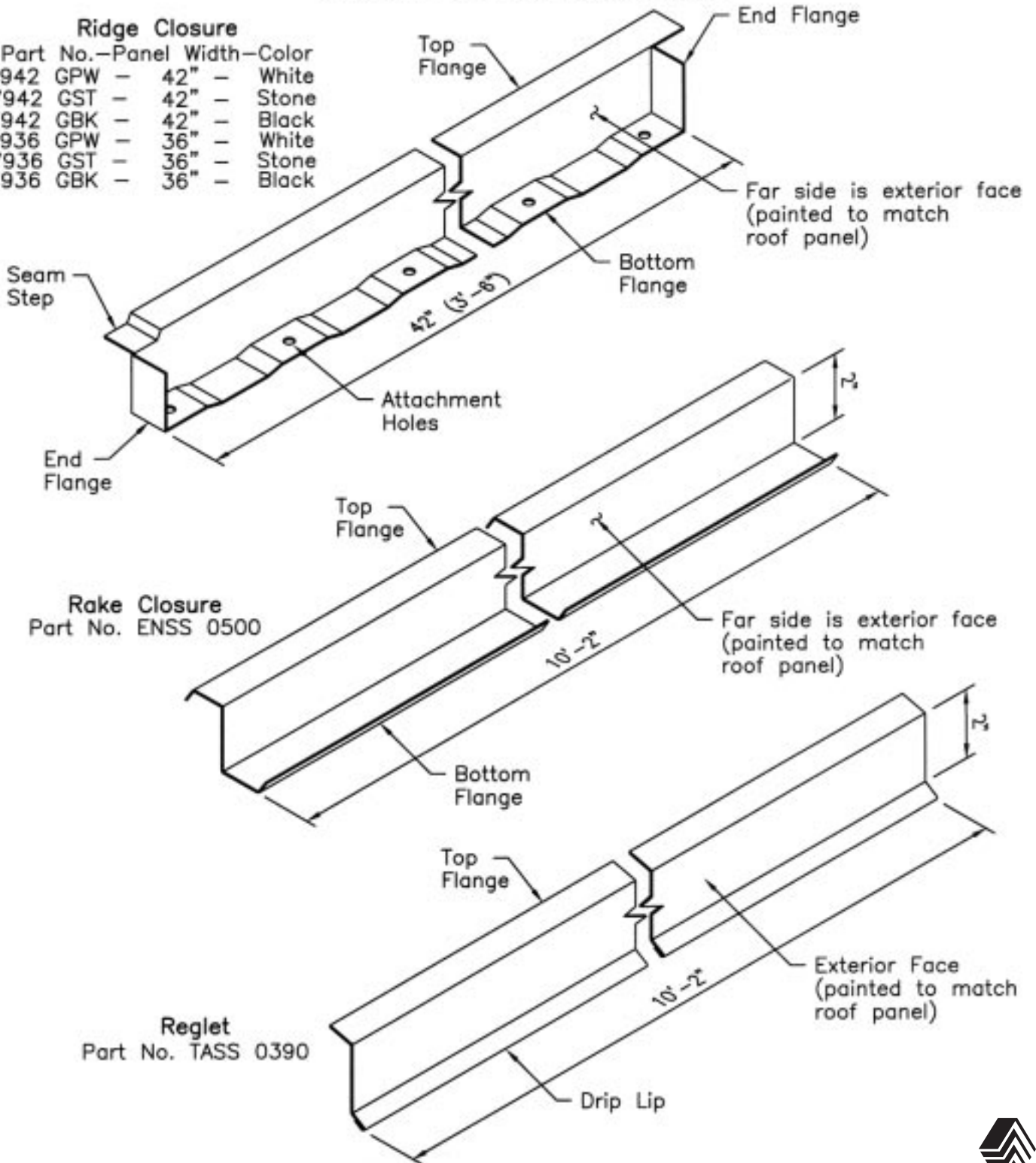

CFR-42 ROOF PANEL

C450.604.1

STANDARD GUTTER PARTS DESCRIPTION

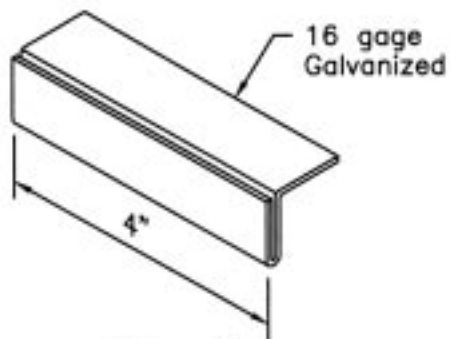

Gutter Clip  
Part No. 4208 GNC

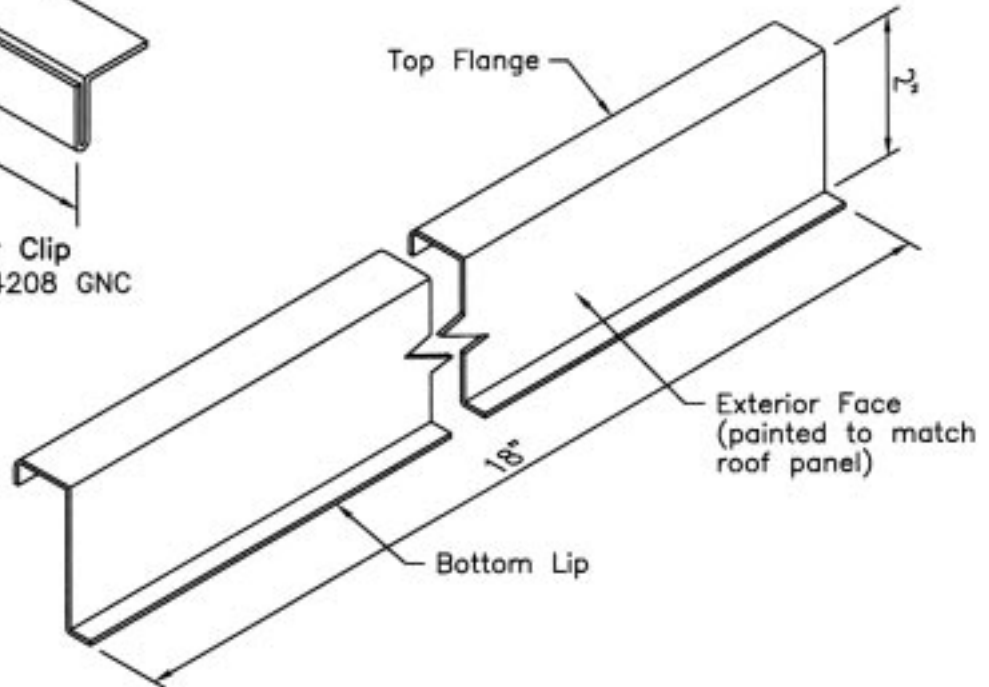

Gutter Support  
(for high profile gutter)  
Part No. GMSS 4X18

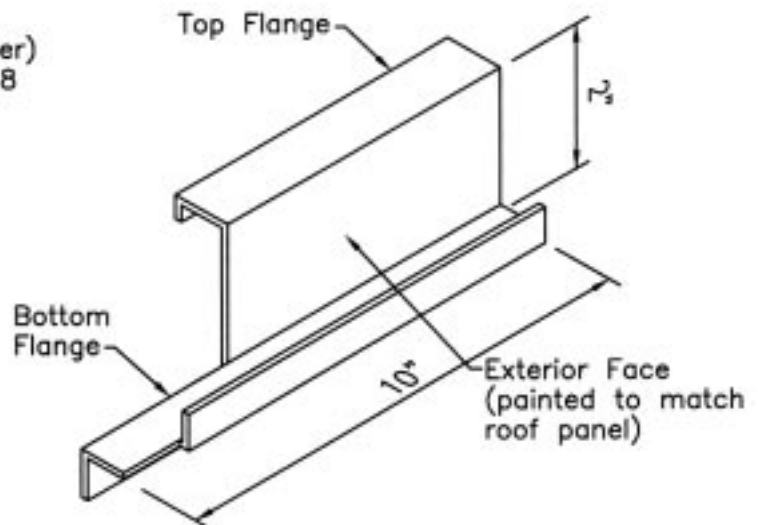

Gutter Support  
(for low profile gutter)  
Part No. GMSS 4X10



CFR-42 ROOF PANEL

C450.620.1

CFR-42 PANEL TOOLS DESCRIPTION

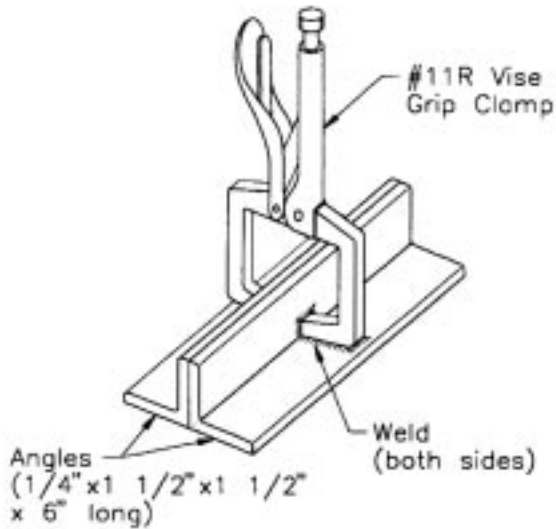

**Rib Clamp**

Part No. 9920 XNC

**Note:** These clamps may be field fabricated or may be ordered from Metl-Span. The clamps must be padded with plastic or cloth tape to avoid marring the roof panel surfaces.

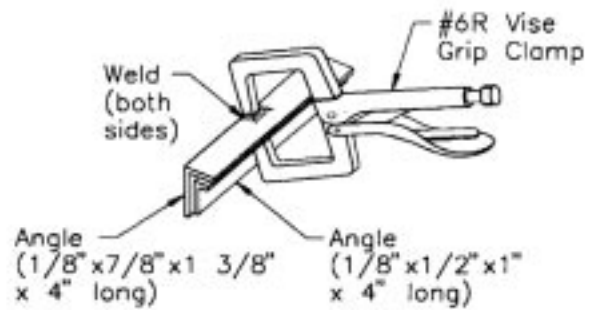

**Seam Clamp**

Part No. 9910 XNC

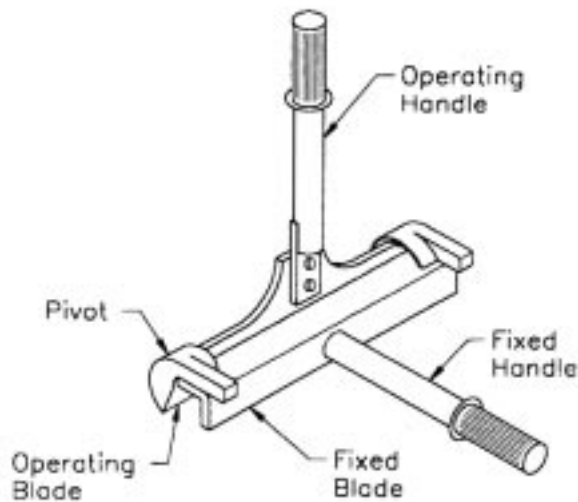

**Manual Seamer**

Part No. 9930 XNC

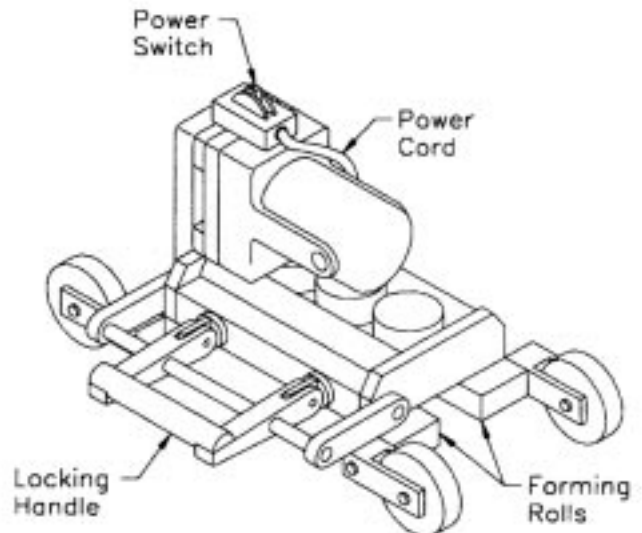

**Motor Seamer**

Part No. 9940 XNC

**Note:** The CFR manual seamer and motor seamer must be ordered from Metl-Span. Do not attempt to seam the roof with other seaming tools which are not specifically designed for the CFR-42 roof.



# CFR-42 ROOF PANEL

C450.605

## SECTION 1 – ROOF PANEL INSTALLATION

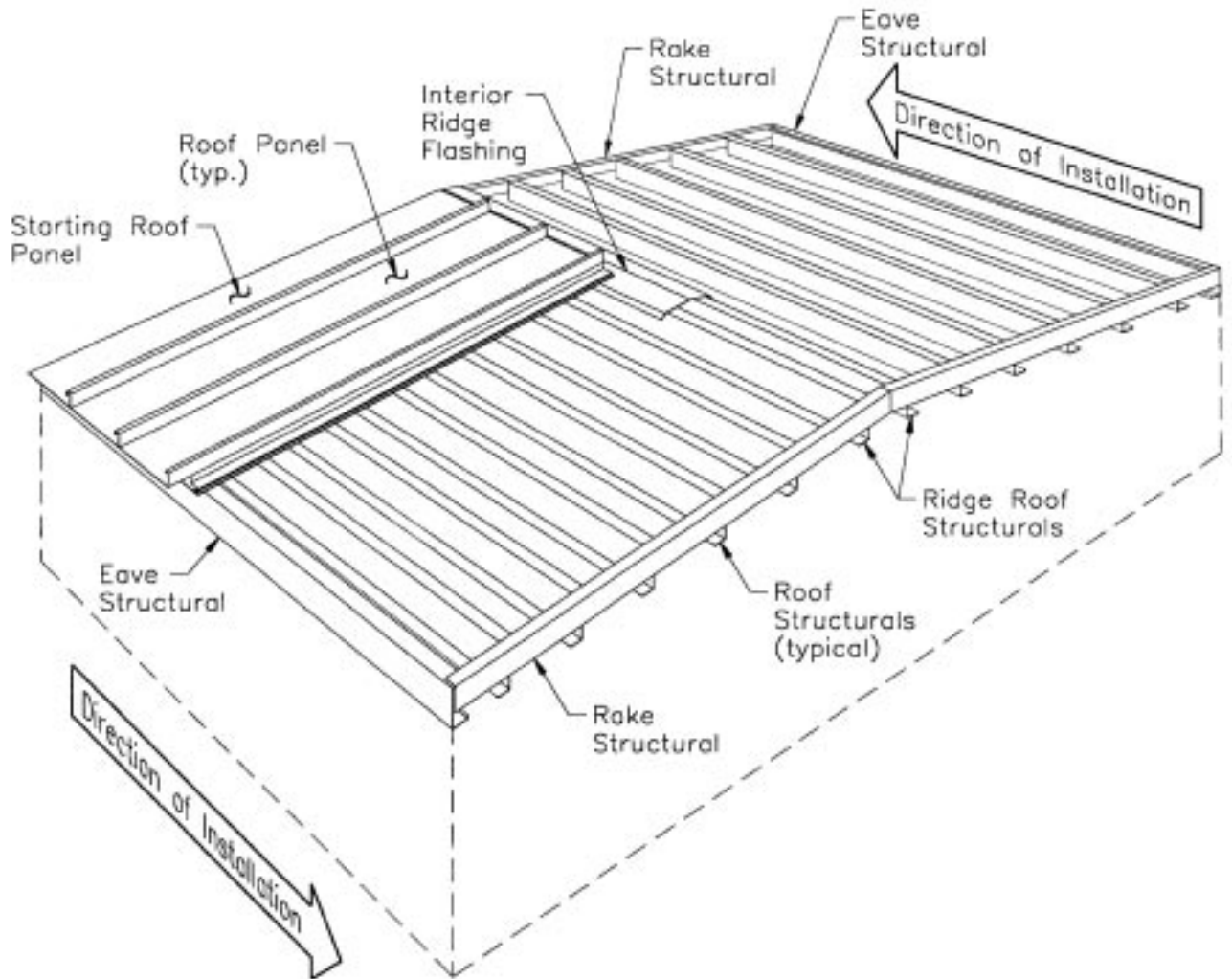

### Typical Roof Panel Installation

This section describes the roof panel installation for a typical roof with a ridge condition.

For other conditions such as roof panel endlaps, high eave trim and high eave transition, refer to that specific section in addition to this section.

## CFR-42 ROOF PANEL

C450.606.1

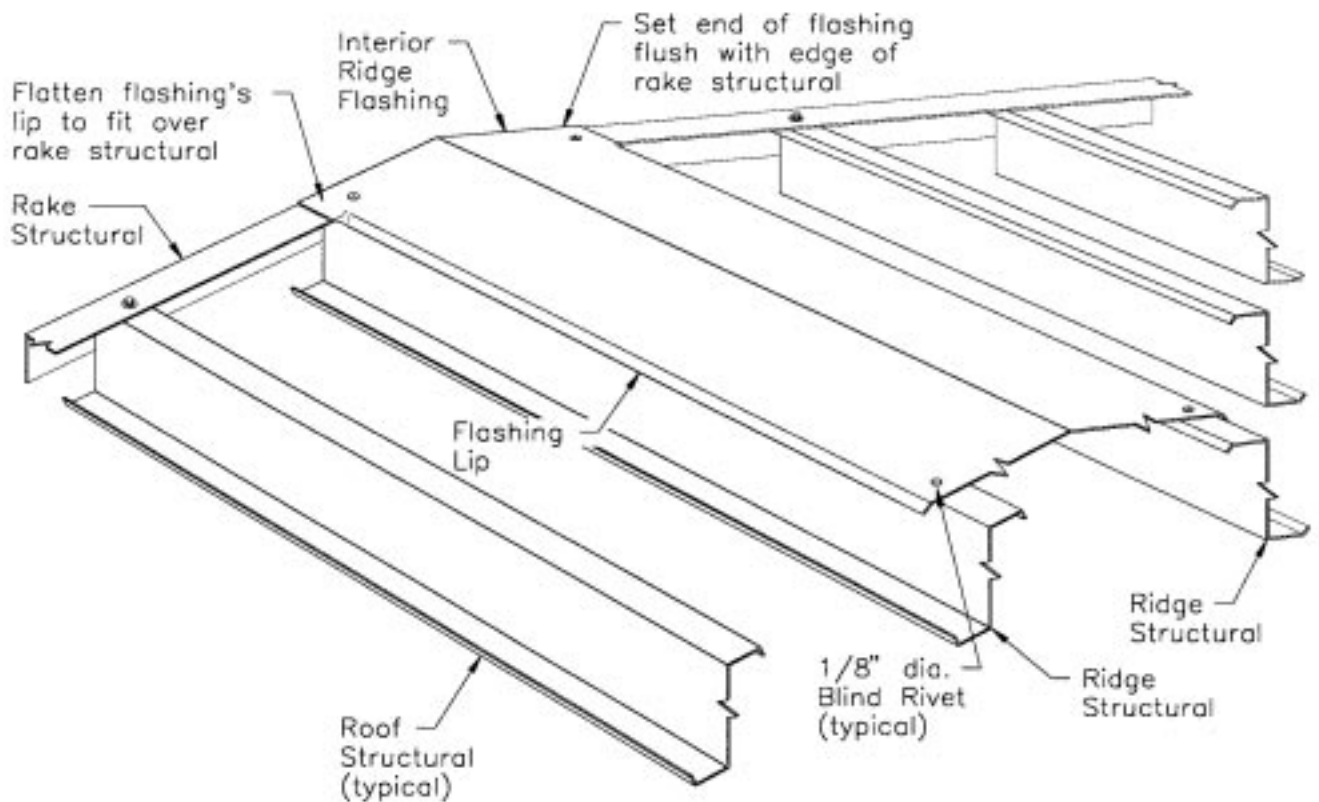

### Interior Ridge Flashing Installation

1. If the roof has a ridge condition, the interior ridge flashing must be installed before the vapor sealant and roof panels are installed.
2. Position the flashing so that it is centered over the ridge structurals.
3. Align the end of the flashing flush with the outer edge of the rake structural.
4. Fasten the flashing to the structurals with 1/8" dia. blind rivets as necessary to secure the flashing until the roof panels are installed.
5. At flashing splices, apply bead of vapor seal caulk, lap flashings 2" and secure lap with blind rivets @ 3" o.c.

## CFR-42 ROOF PANEL

C450.607

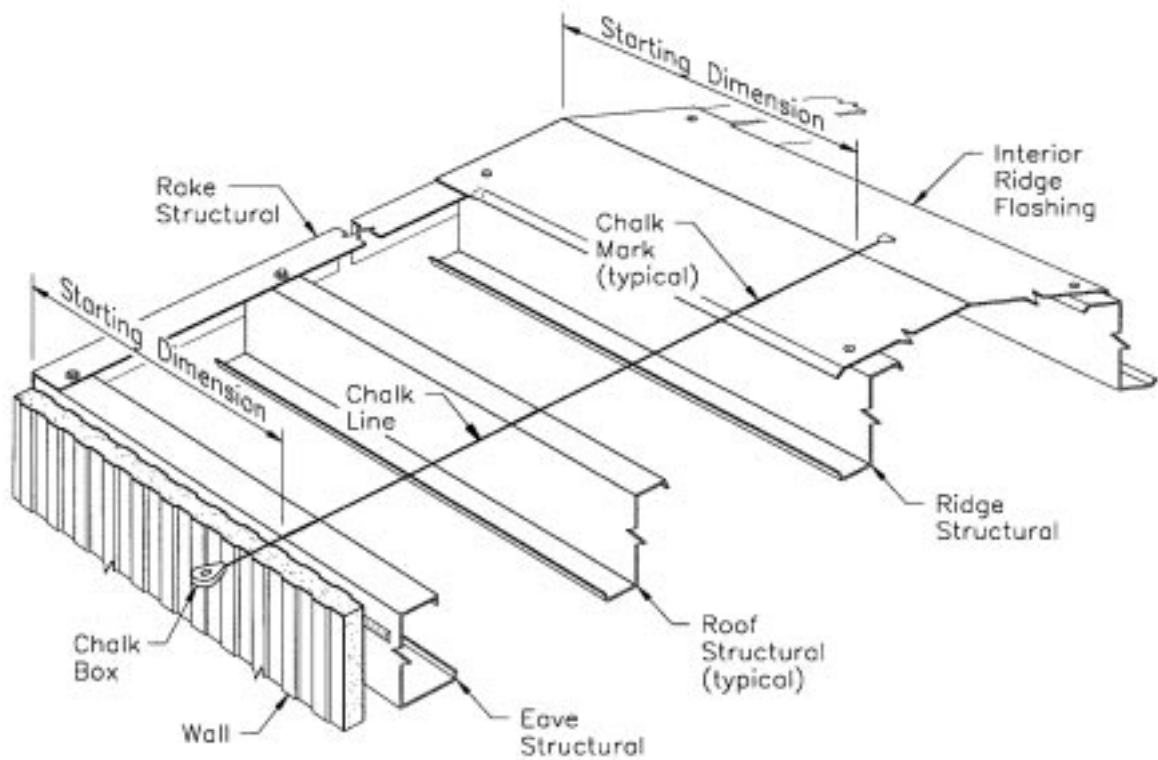
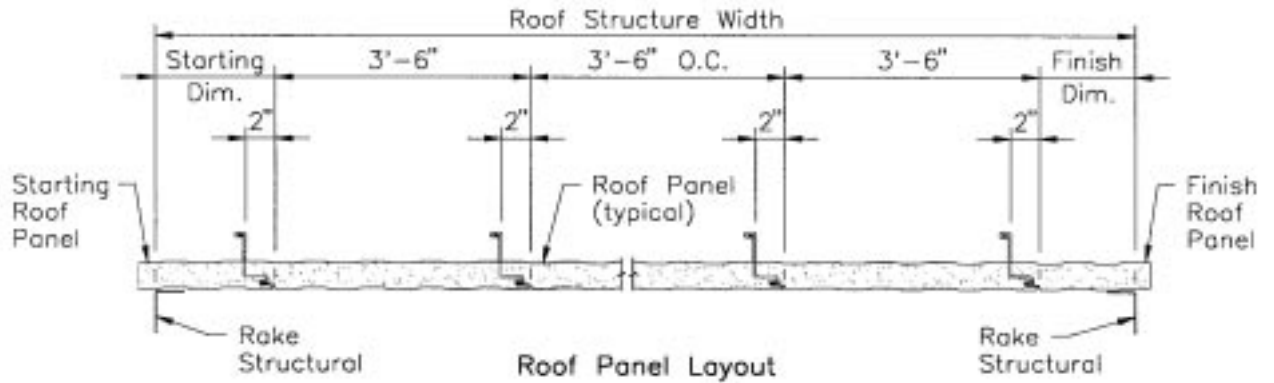

### Starting Dimension Layout

1. Determine the starting dimension. Note: The starting dimension may be shown on the job's installation drawings.
2. Measure the starting dimension from the face of the rake structural and mark the dimension on the eave structural and the ridge or high eave structural.
3. Stretch a chalk line between the marks and snap the chalk line across the roof structurals.

## CFR-42 ROOF PANEL

C450.608

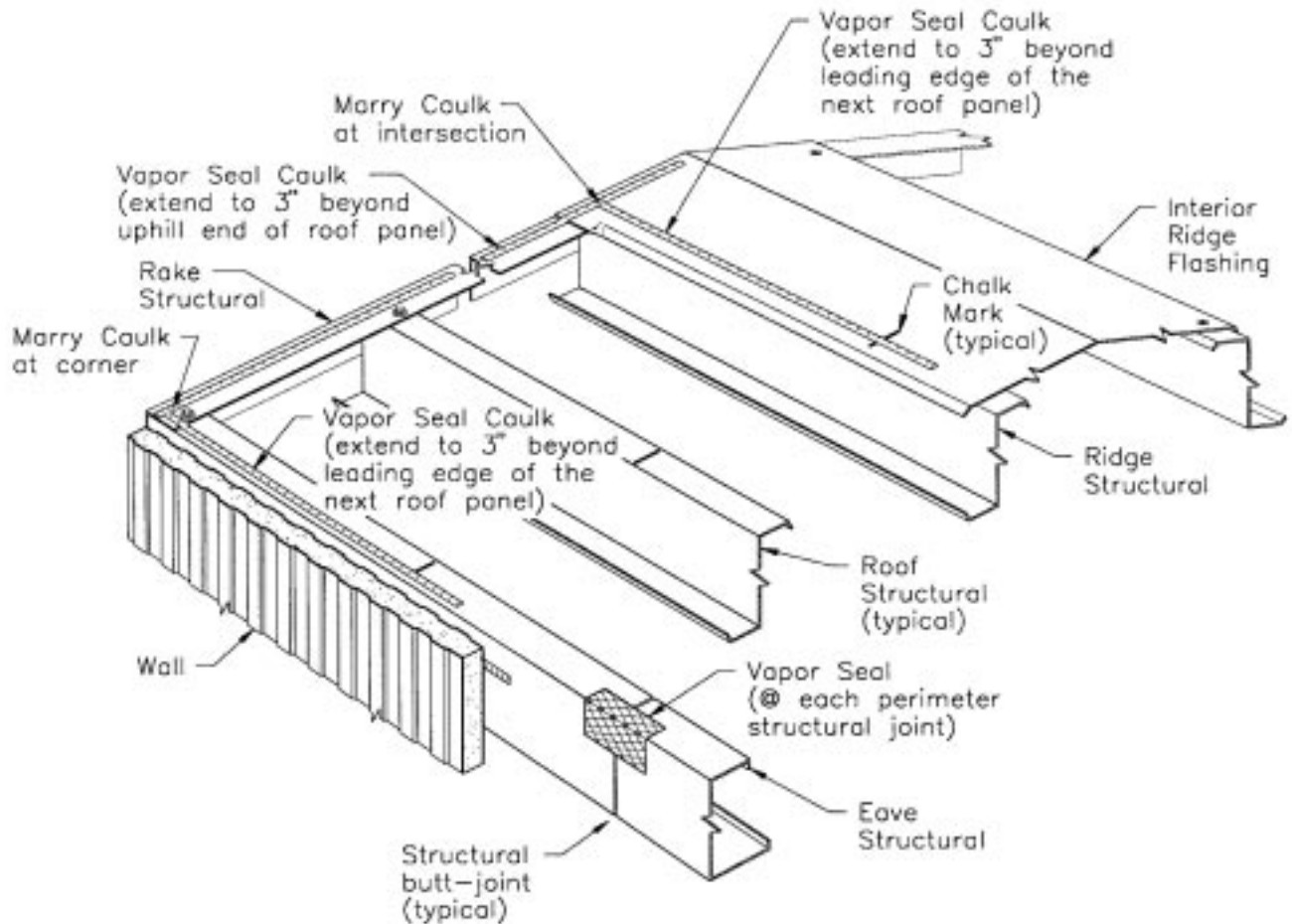

### Perimeter Vapor Seal Application

1. Apply continuous beads of vapor seal caulk along the rake and eave structurals and along the ridge flashing.
2. To avoid damage or contamination of the caulk, do not apply until immediately before installation of the next roof panel and apply only as much caulk as needed for that panel.
3. Apply the caulking bead large enough to assure filling the roof panel's interior face mesa ribs.
4. Ensure that the perimeter structural joints have been vapor sealed. Note: These seals are not specified or provided by Metl-Span.
5. Important: Cold storage applications may not require the vapor seal at the roof's interior face. Refer to the installation drawings for specific instructions.



## CFR-42 ROOF PANEL

C450.609

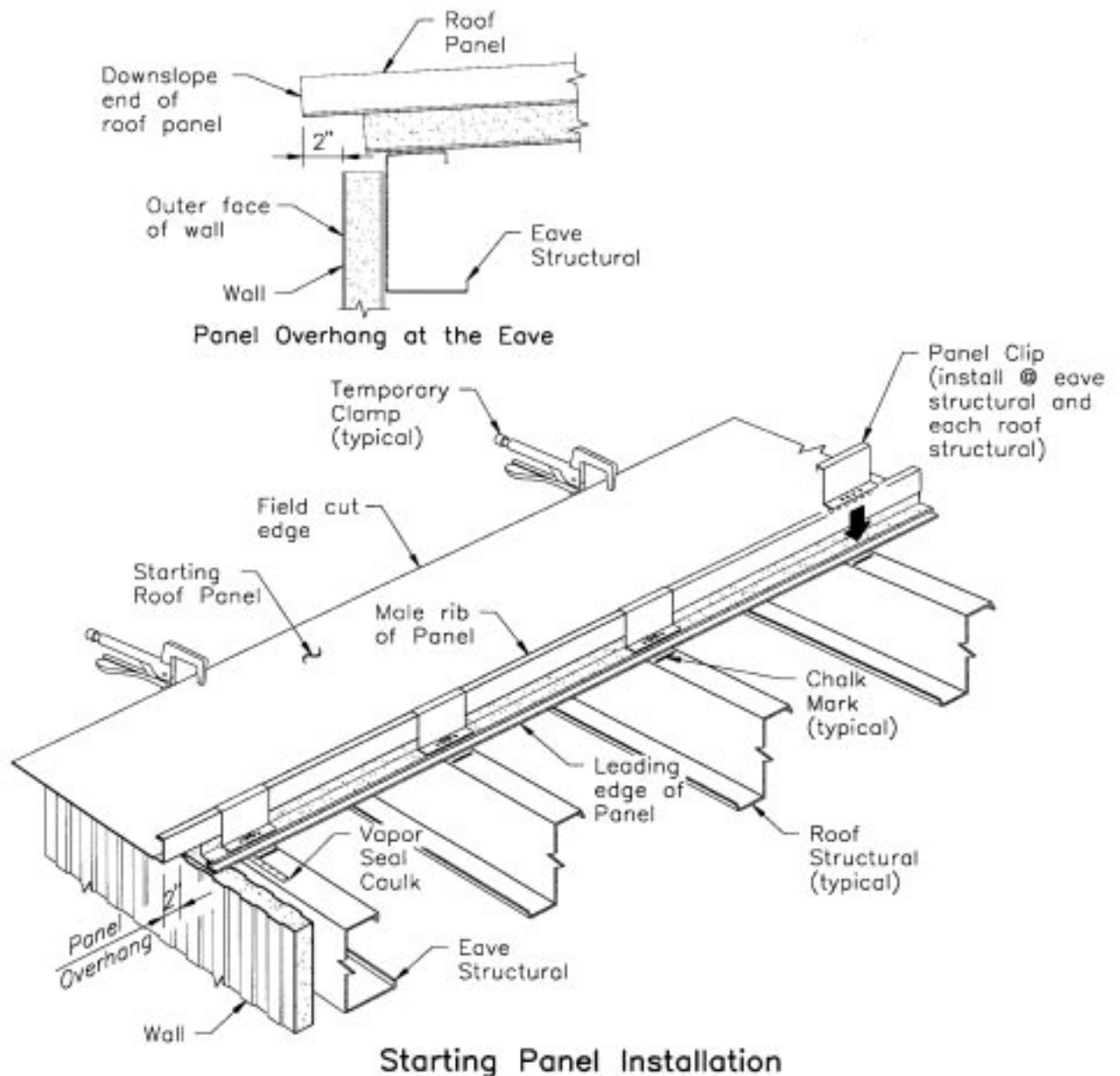

1. Field cut the starting panel to the required width and clean the panel of cutting residue.
2. Position the leading edge of the starting panel along the starting dimension chalk marks.
3. Position the end of the panel at 2" beyond the face of the wall. This dimension may vary for specific job conditions, refer to the job's installation drawings.
4. Temporarily clamp (or fasten) the cut edge of the panel to the rake structural.
5. Secure the leading edge of the panel to the eave and roof structural with the panel clips. See following Panel Clip Installation Detail.

## CFR-42 ROOF PANEL

C450.610

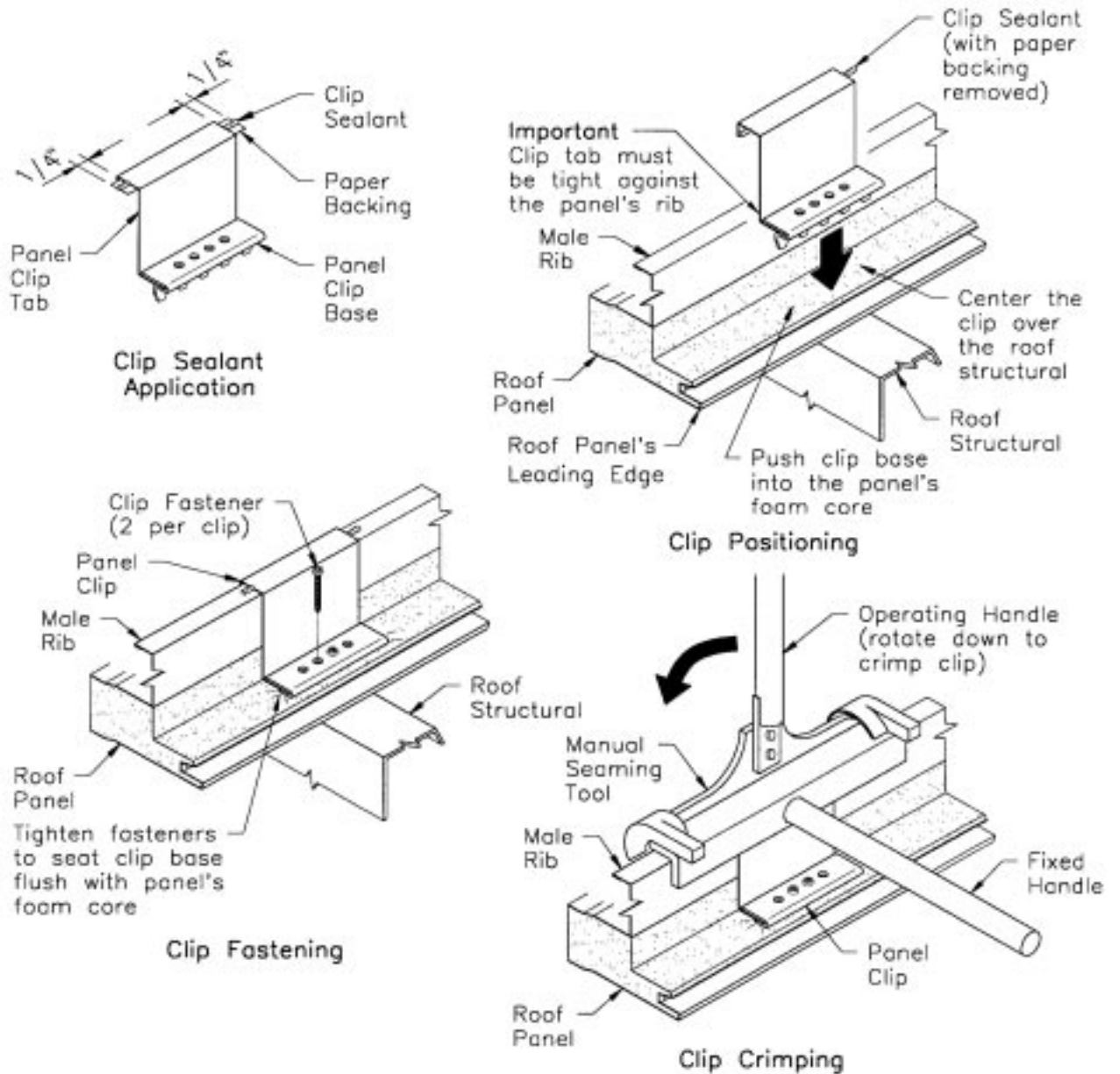

### Panel Clip Installation

1. Apply clip sealant to underside of the clip's tab. Extend sealant 1/4" beyond ends of clip tab.
2. Remove sealant's paper backing and position clip over the panel's leading edge. Align the clip's center attachment holes over the roof structural's top flange.
3. While holding the clip tight against the panel's edge, push the clip's base into the panel's foam core.
4. Fasten the clip to the roof structural with two clip fasteners.
5. Crimp the clip's tab around the panel's male rib with the manual seaming tool.



## CFR-42 ROOF PANEL

C450.611

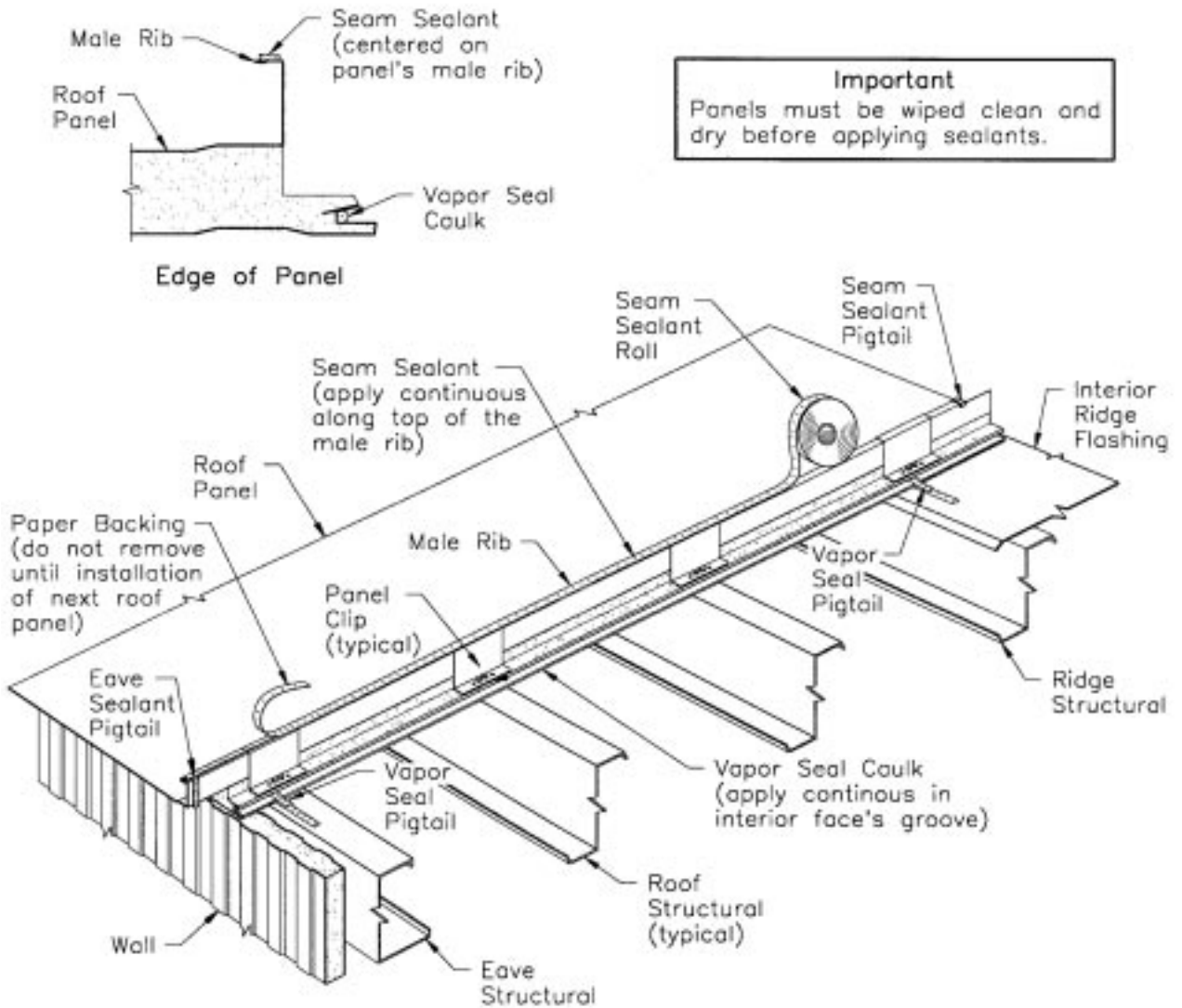

1. Apply seam sealant continuously along top of the panel's male rib. Use the sealant's paper backing as a guide to center the sealant on the rib. The seam sealant must marry with the exposed clip sealant.
2. Apply vapor seal caulk continuously in the panel's interior face groove.
3. Apply vapor seal caulk pigtails to connect the vapor seal in the groove with the vapor seal on the eave structural and on the interior ridge flashing. The pigtails must marry with the vapor seals.
4. Apply seam sealant pigtails at the eave and ridge ends of the panel's male rib. See following Sealant Pigtail Application Detail.

## CFR-42 ROOF PANEL

### C450.612.1

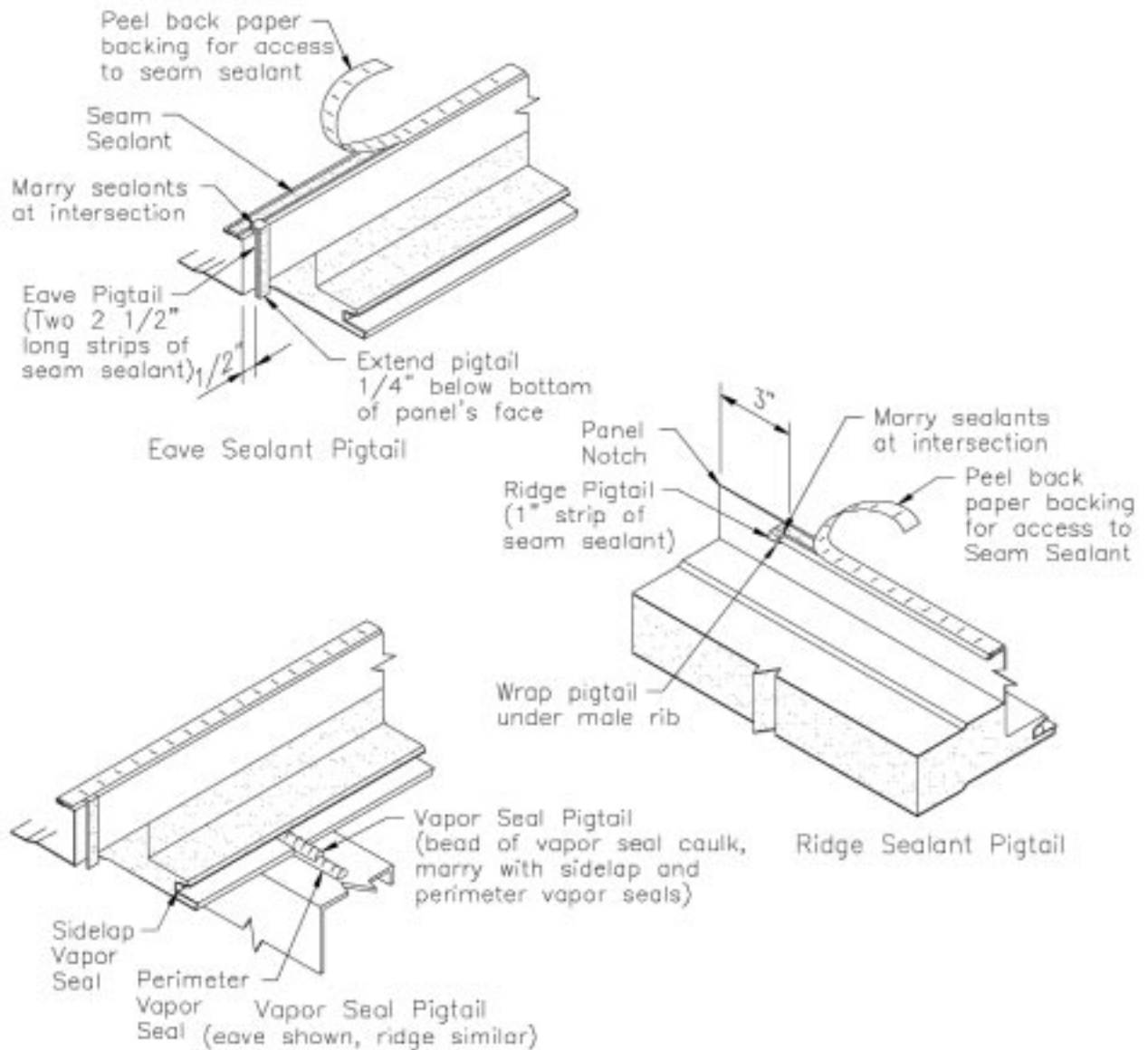

### Sealant Pigtail Application

1. Apply eave sealant pigtail at the panel's eave end. Put two strips together to double the thickness. The pigtail must marry with the seam sealant and extend below the panel's face to later engage the sealant on the eave trim.
2. Apply ridge sealant pigtail at the panel's ridge end. The pigtail must marry with the seam sealant and must cover the full width of the male rib's underside.
3. Do not remove the pigtails paper backings until installation of the next panel.
4. Apply vapor seal pigtails at the panel's eave and ridge end. The pigtails must marry with the vapor seal in the panel's groove and the eave and ridge perimeter vapor seals.

## CFR-42 ROOF PANEL

C450.613

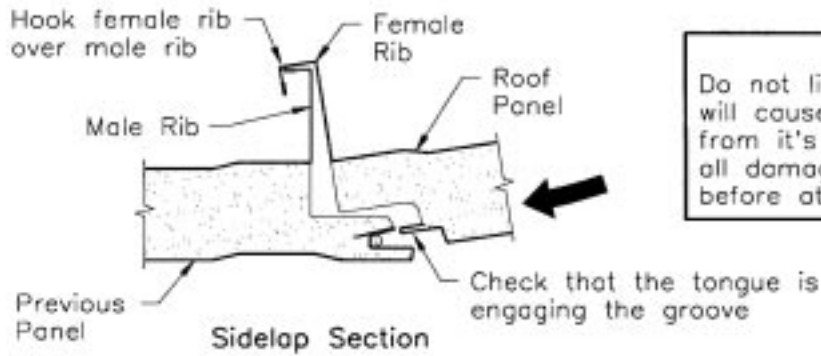

**Important**  
Do not lift panels in a manner which will cause the panel's face to separate from its foam core. Check and repair all damage to the panel's edge's before attempting to install the panel.

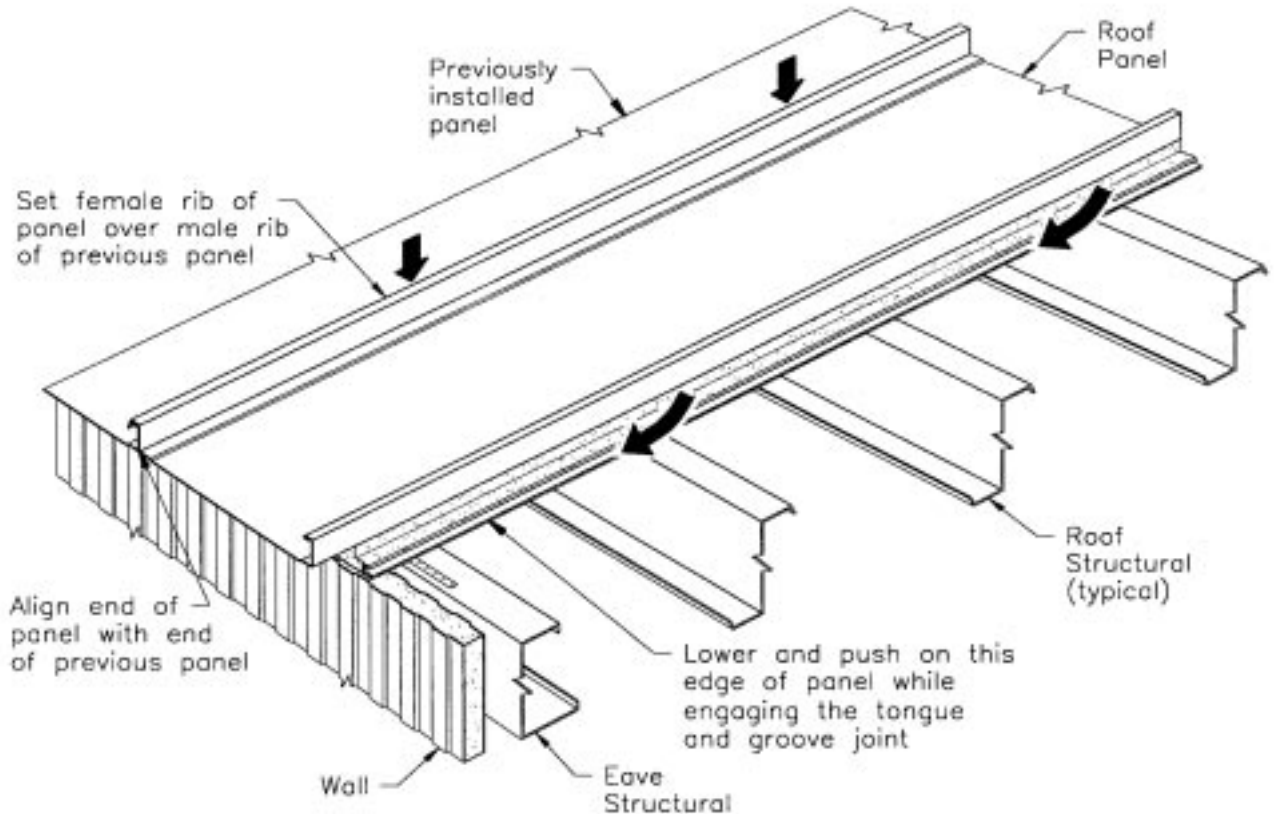

### Panel Sidelap Engagement

1. Remove the paper backing from the seam sealant on the previously installed panel.
2. Carry the roof panel to its position next to the previous panel.
3. Tilt the panel to hook its female rib over the male rib of the previous panel.
4. Align the eave end of the panel with the end of the previous panel.
5. Lower and push on the leading edge of the panel so that its tongue engages the groove of the previous panel.

## CFR-42 ROOF PANEL

C450.614

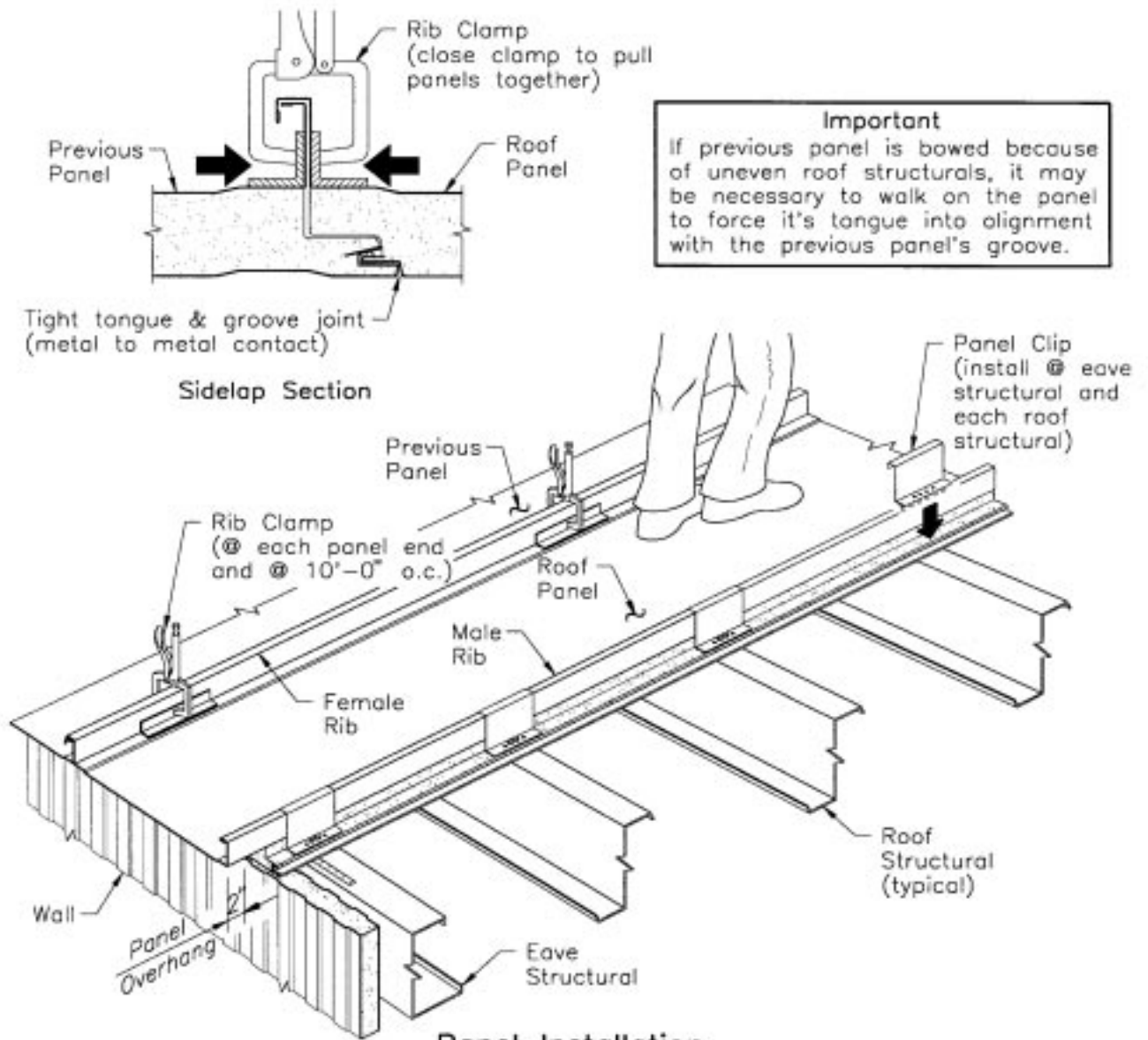

1. Check that the end of the panel is 2" beyond the outer face of the wall. Refer to the job's Installation Drawings for variations of this dimension.
2. Use the rib clamps to pull the panel sidelap together.
3. Check that the panel's tongue and groove joint is fully engaged, metal to metal contact at the interior face is desired.
4. Important: If the adjacent panels are bowed due to vertical misalignment of the roof structurals or thermal bowing, it may be necessary to walk along the panel's trailing edge to force the panel's tongue into vertical alignment with the previous panel's groove. Then use the rib clamps to pull the panel sidelap together.
5. Secure the leading edge of the panel to the eave and roof structurals with the panel clips.



## CFR-42 ROOF PANEL

C450.615

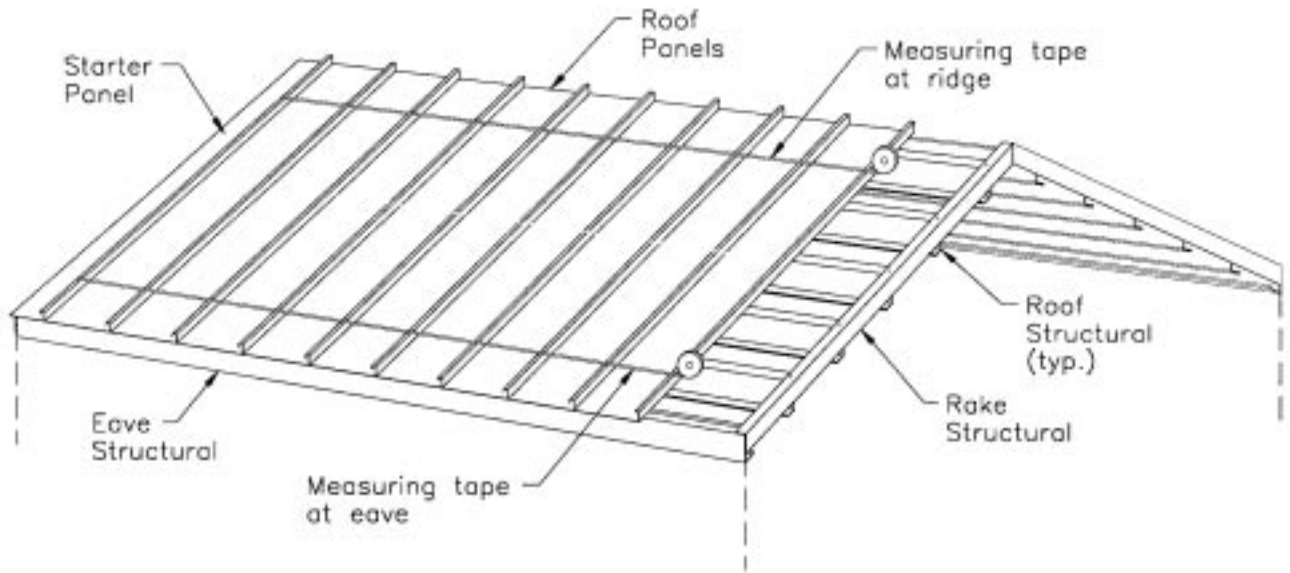

### Checking Panel Coverage

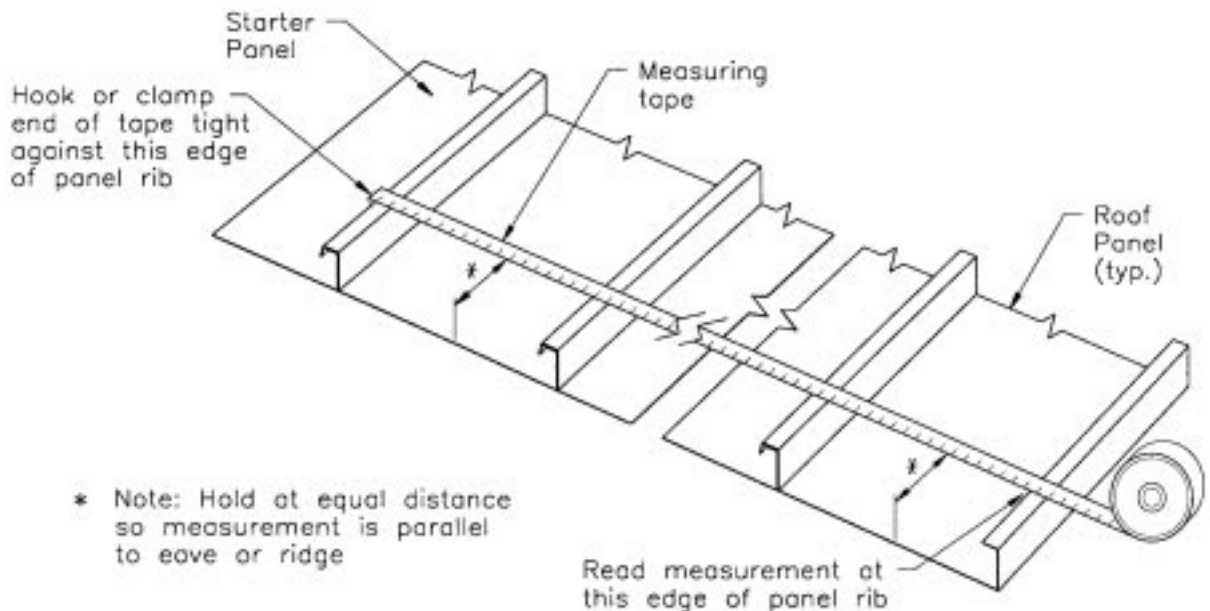

### Panel Coverage Measurement

1. To assure proper fit-up of the finish rake, ridge closures and roof accessories. The panel coverage must be checked frequently and corrected as necessary.
2. During the panel installation, adjust the closing pressure of the rib clamps to provide an exact 42" coverage per panel.
3. If correction is required, do not attempt more than +1/8" or -1/16" correction per panel.

## CFR-42 ROOF PANEL

C450.616

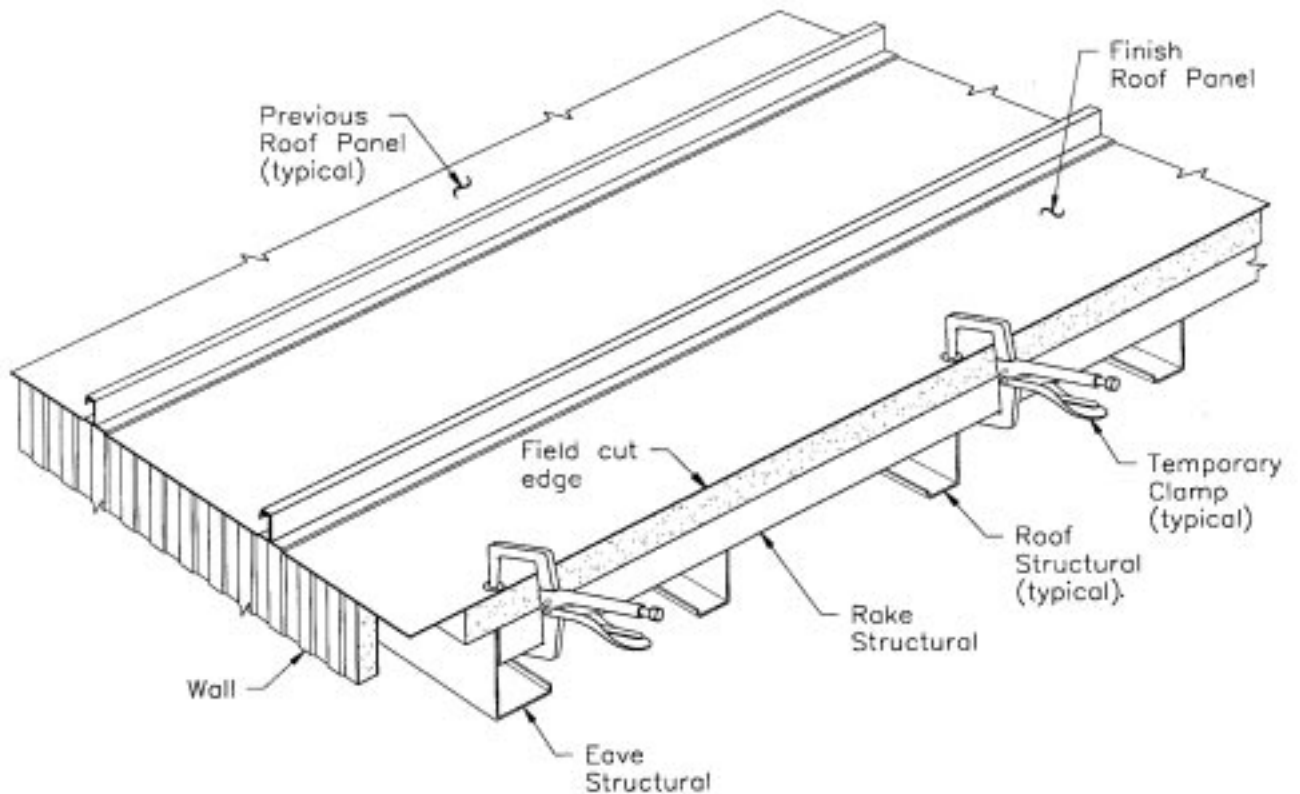

### Finish Panel Installation

1. Complete the installation of all the roof panels except for the finish panel.
2. Field cut the finish panel to the required width and clean the panel of cutting residue.
3. Install the finish panel and temporarily clamp the cut edge of the panel to the rake structural.



# CFR-42 ROOF PANEL

C450.617

## SECTION 2 – ENDLAP ASSEMBLY

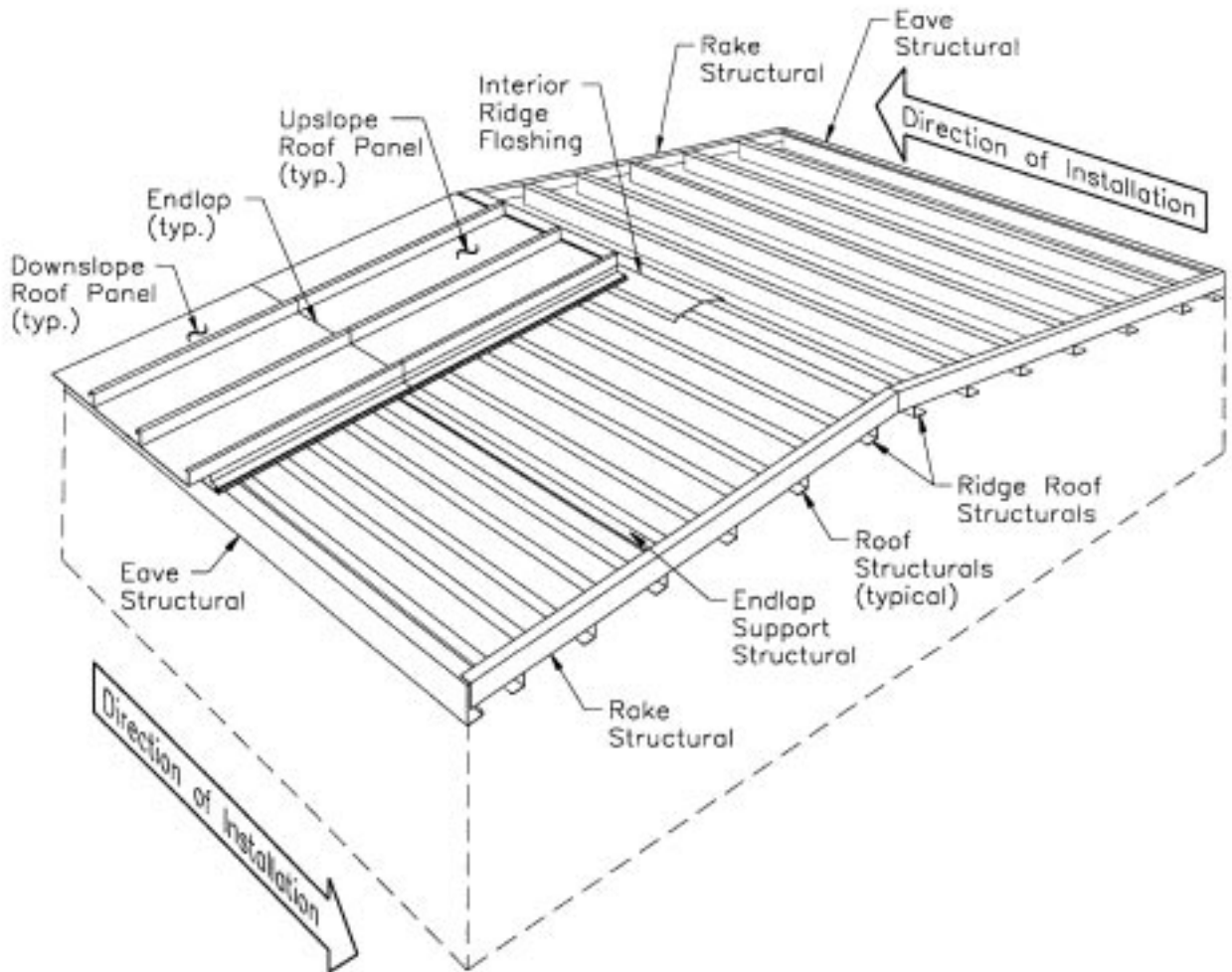

### Typical Roof With Endlap Condition

This section describes the assembly of roof panel endlaps for a typical roof with endlap conditions.

Use this section in conjunction with the previous Roof Panel Installation section.

## CFR-42 ROOF PANEL

C450.618

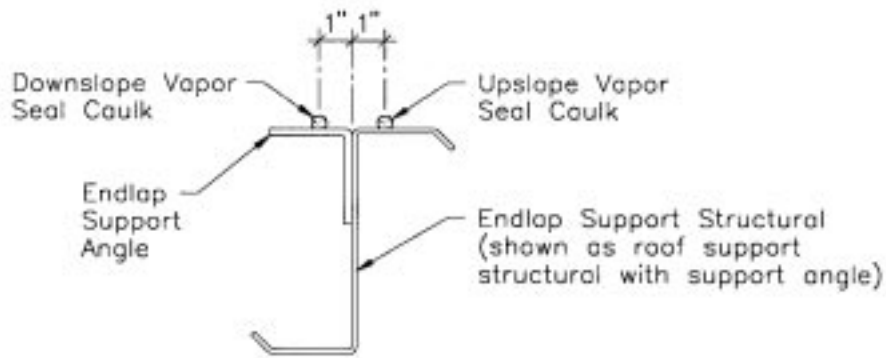

Endlap Support Structural Section

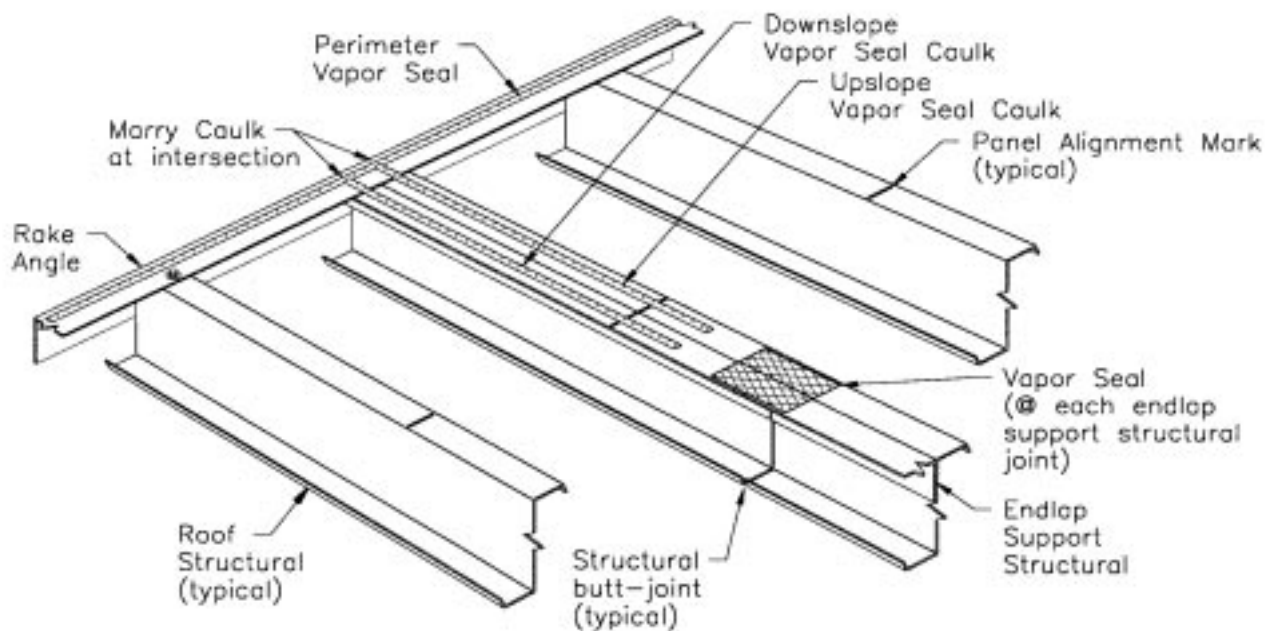

### Endlap Vapor Seal Application

1. Apply continuous beads of vapor seal caulk upslope and downslope of the center of the endlap support structural.
2. To avoid damage or contamination of the caulk, do not apply until immediately before installation of the next roof panel and apply only as much caulk as needed for that panel.
3. Apply the caulking bead large enough to ensure filling the roof panel's interior face mesa ribs.
4. Ensure that the endlap support structurals joints have been vapor sealed.  
Note: These seals are not specified or provided by Metl-Span.
5. Important: Cold storage applications may not require the vapor seal at the roof's interior face. Refer to the installation drawings for specific instructions.

## CFR-42 ROOF PANEL

C450.619.1

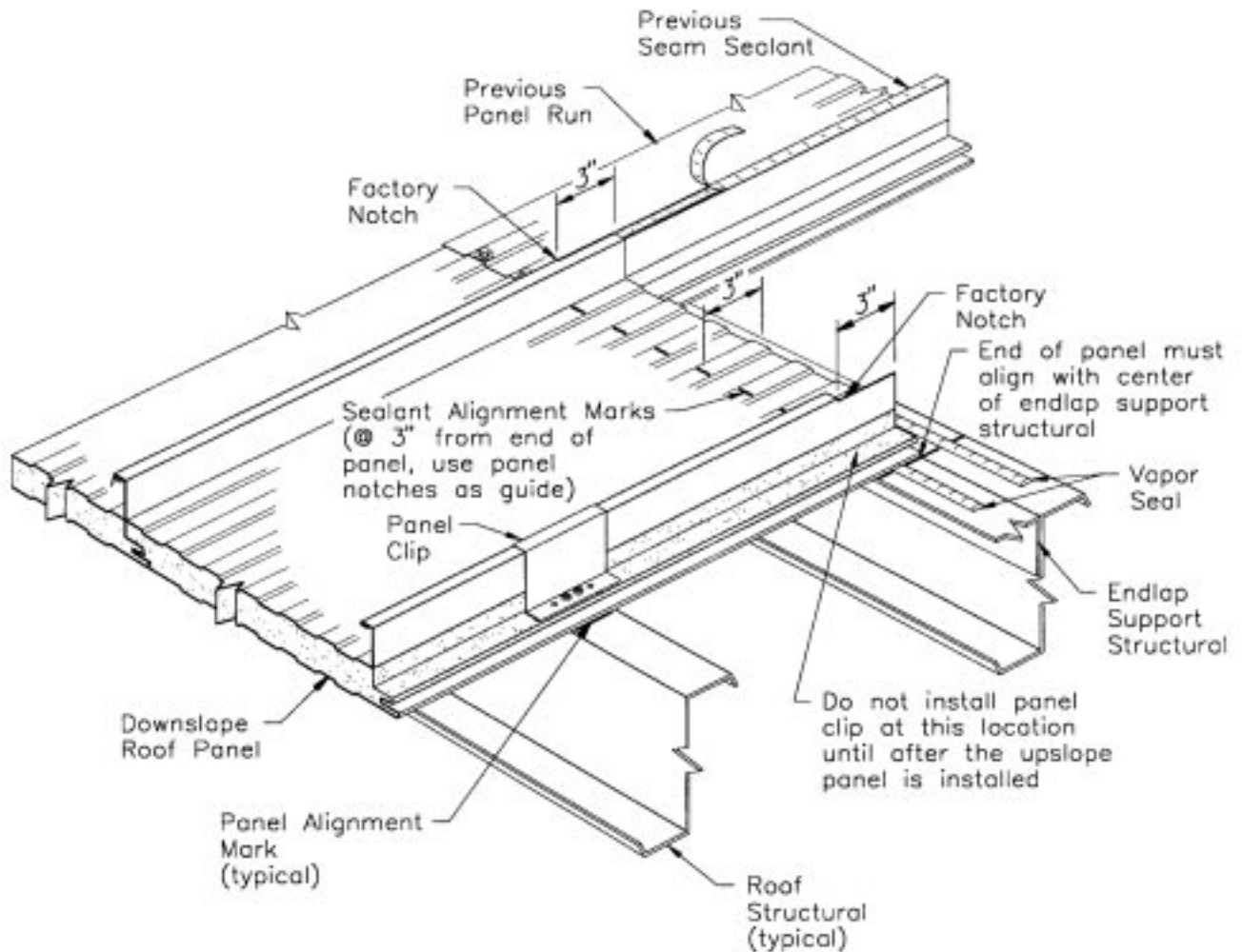

### Downslope Panel Installation

1. Position the downslope panel and check that its end aligns with the center of the endlap support structural  $\pm 1/2"$ .
2. Install the panel and secure with the panel clips. Do not install the panel clip at the endlap until after the upslope panel is installed.
3. Layout and mark the endlap sealant location at 3" from the end of the panel.

## CFR-42 ROOF PANEL

### C450.621.1

**Important**  
The panel's surface must be wiped clean and dry before application of the endlap sealant.

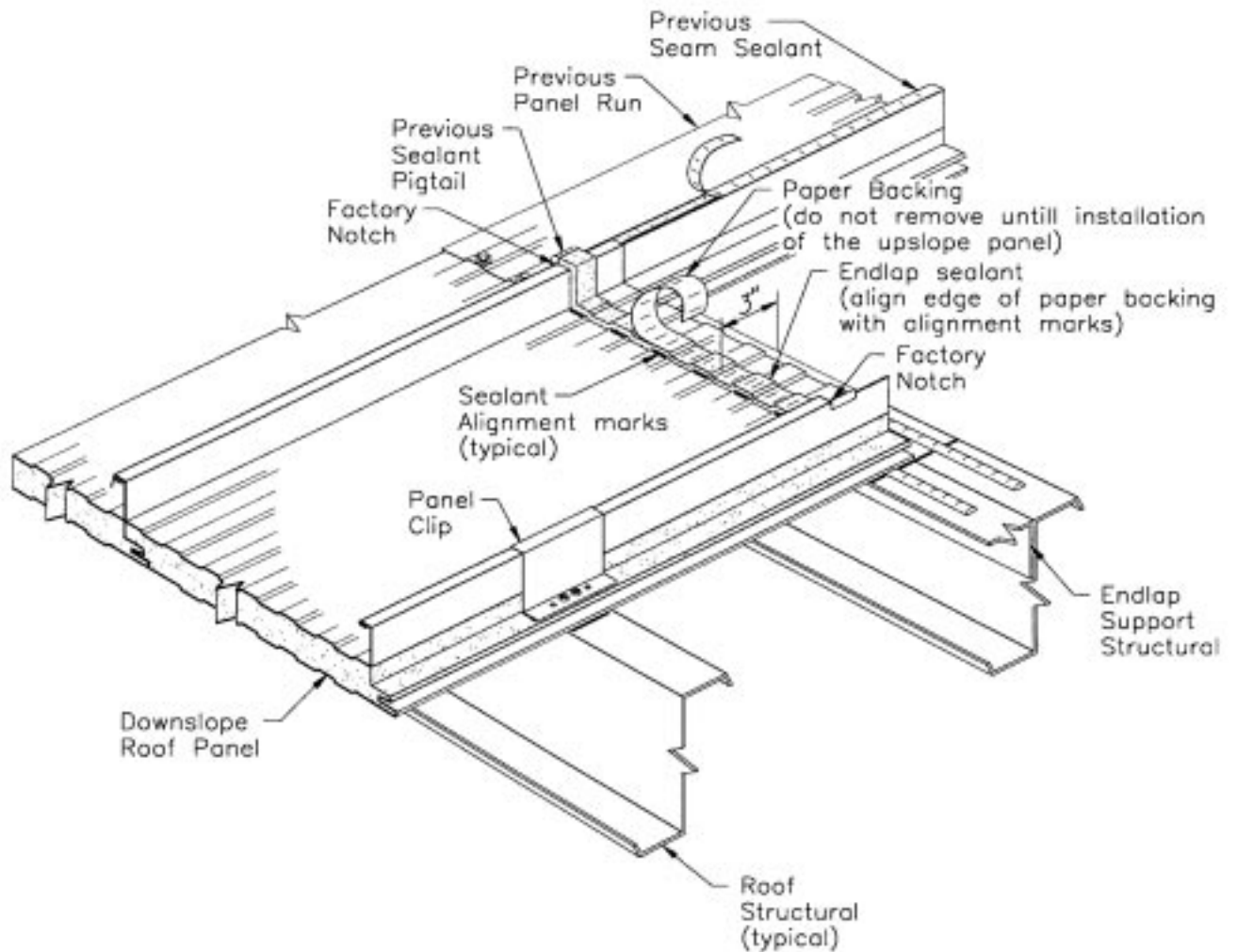

### Endlap Sealant Application

1. Apply endlap sealant continuous across the panel. Align the edge of the sealant's paper backing with the alignment marks. See following Sealant Placement detail.
2. At this time, check that all of the panel's backer plates are in position. See Standard Roof Panel Description detail. Contact Metl-Span for replacement plates and installation instructions for backer plate locations.



## CFR-42 ROOF PANEL

### C450.622.1

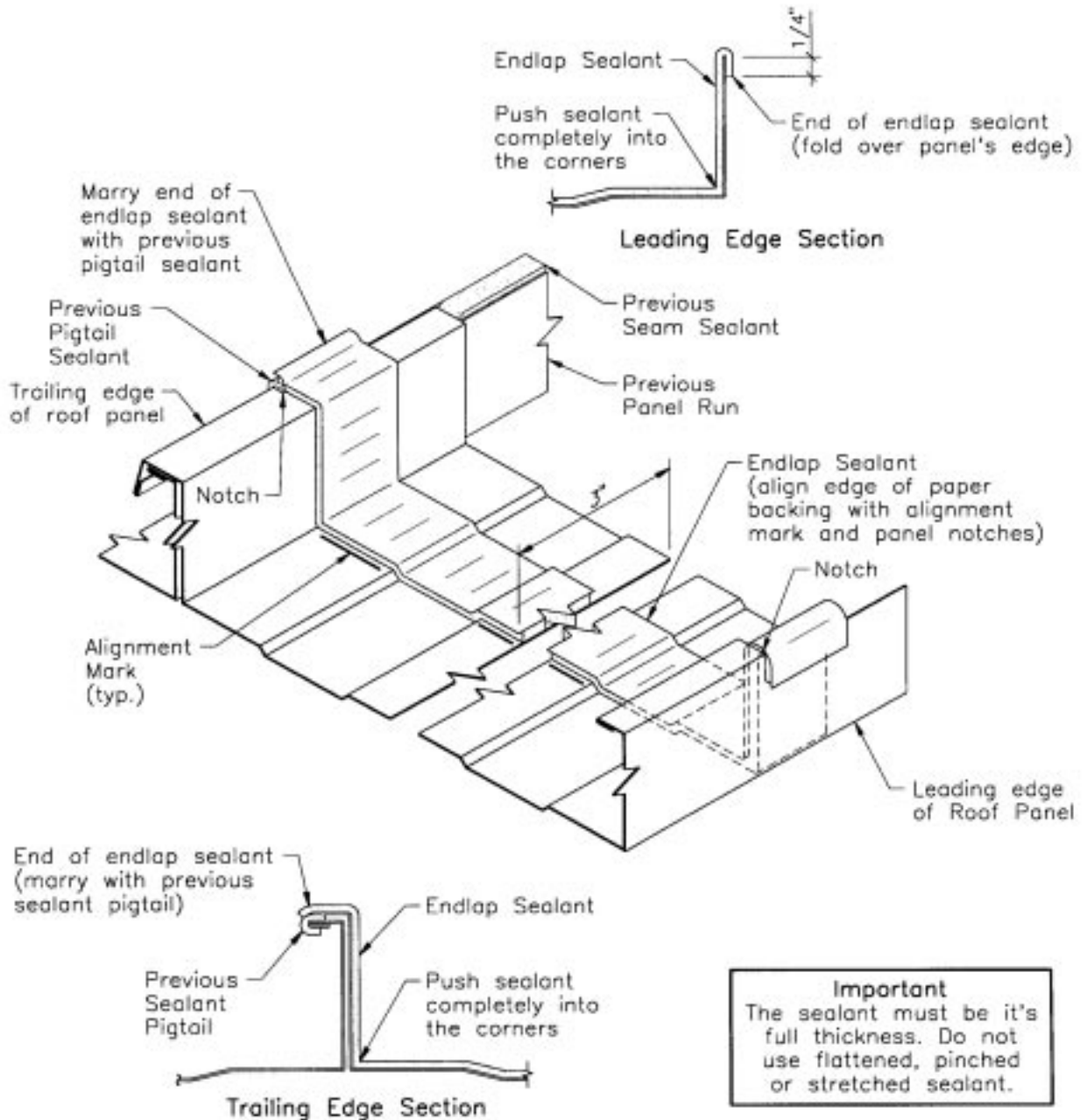

### Endlap Sealant Placement

1. Start the endlap sealant by marrying its end to the previous sealant pigtail.
2. Apply the endlap sealant continuous across the panel. Align the edge of the paper backing with the alignment marks and panel notches. Be sure that it is pushed completely into all of the panel's corners.
3. Finish the endlap sealant by folding its end 1/4" over the panel's leading edge.

## CFR-42 ROOF PANEL

### C450.623.1

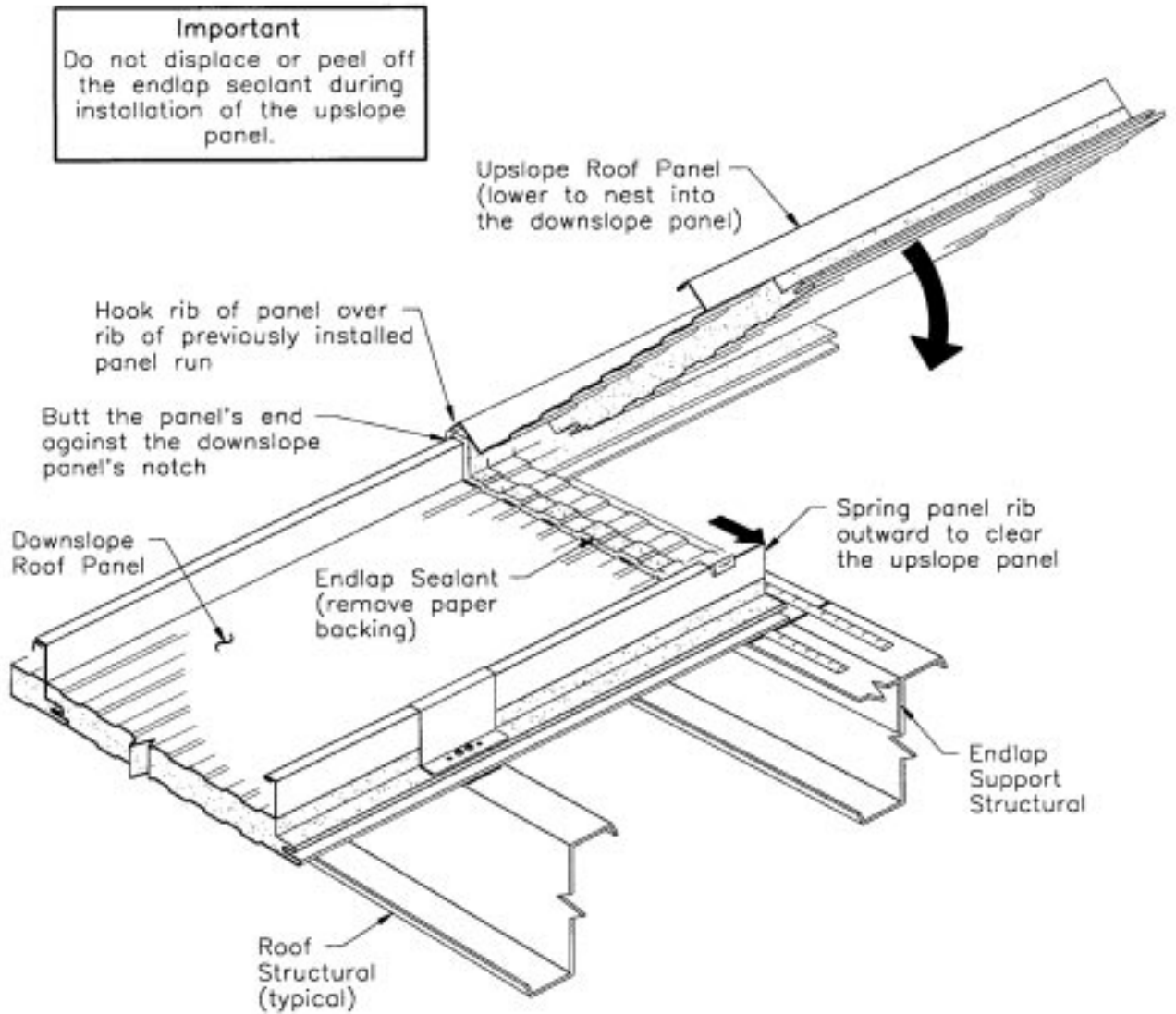

### Upslope Panel Engagement

1. Position the upslope panel so the end of its female rib butts the notch of the downslope panel. Be sure the panel's tongue is engaging the previous panel's groove.
2. Push the male rib of the downslope panel outward and lower the upslope panel to nest into the downslope panel.
3. Check that the endlap sealant is not displaced or peeled off when the upslope panel is lowered into the downslope panel.



## CFR-42 ROOF PANEL

C450.624

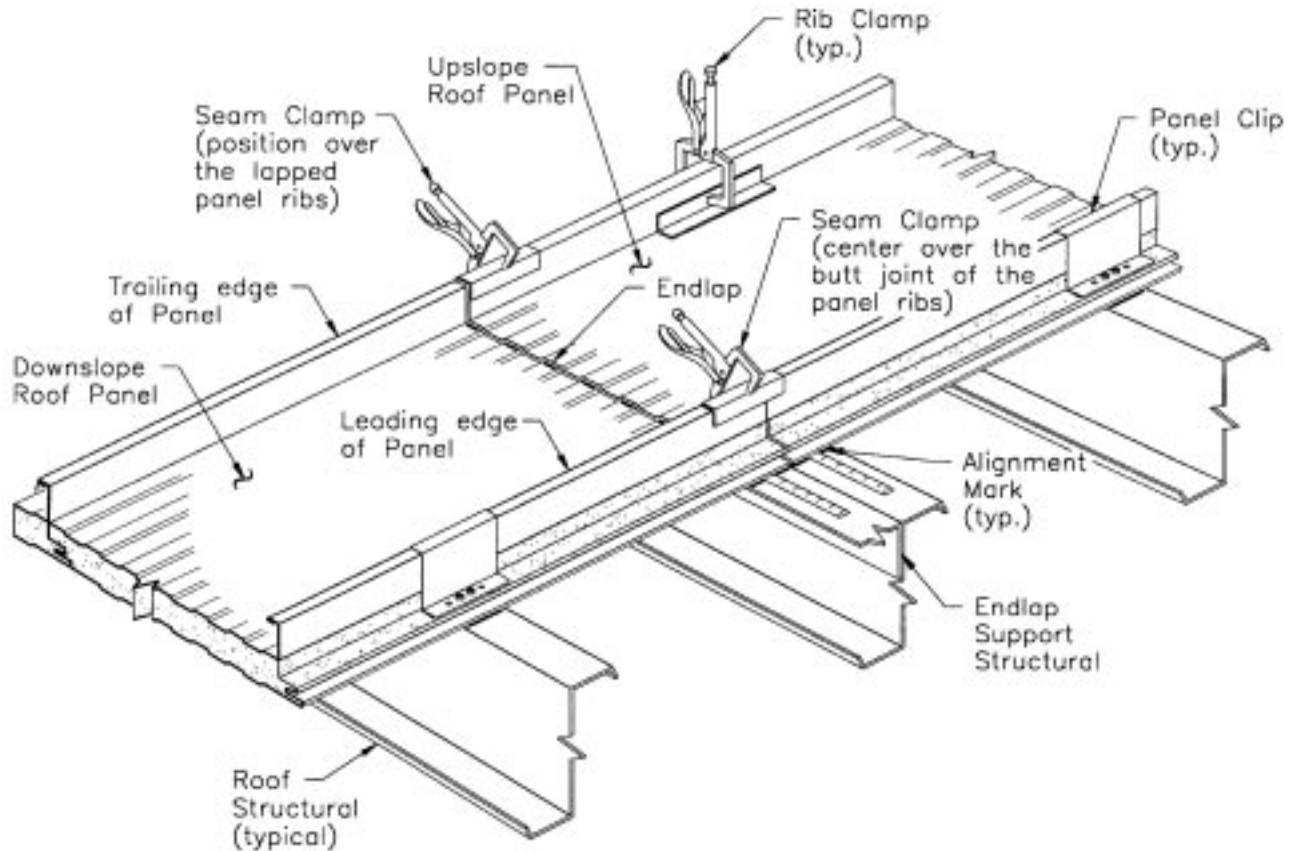

### Upslope Panel Installation

1. Use rib clamps to pull the upslope panel sidelap together. Check that the panel is aligned to the alignment marks. Secure the panel to the roof structurals with panel clips. Do not install clips at the endlap until the endlap assembly is completed.
2. Compress the endlap together by using seam clamps on the panel ribs. At the trailing edge, position the clamp over the lapped ribs. At the leading edge position the clamp to straddle both (upslope and downslope) ribs.
3. In cold weather, close the clamps slowly to allow the sealant to flow and prevent distortion of the panel ribs.

## CFR-42 ROOF PANEL

C450.625.1

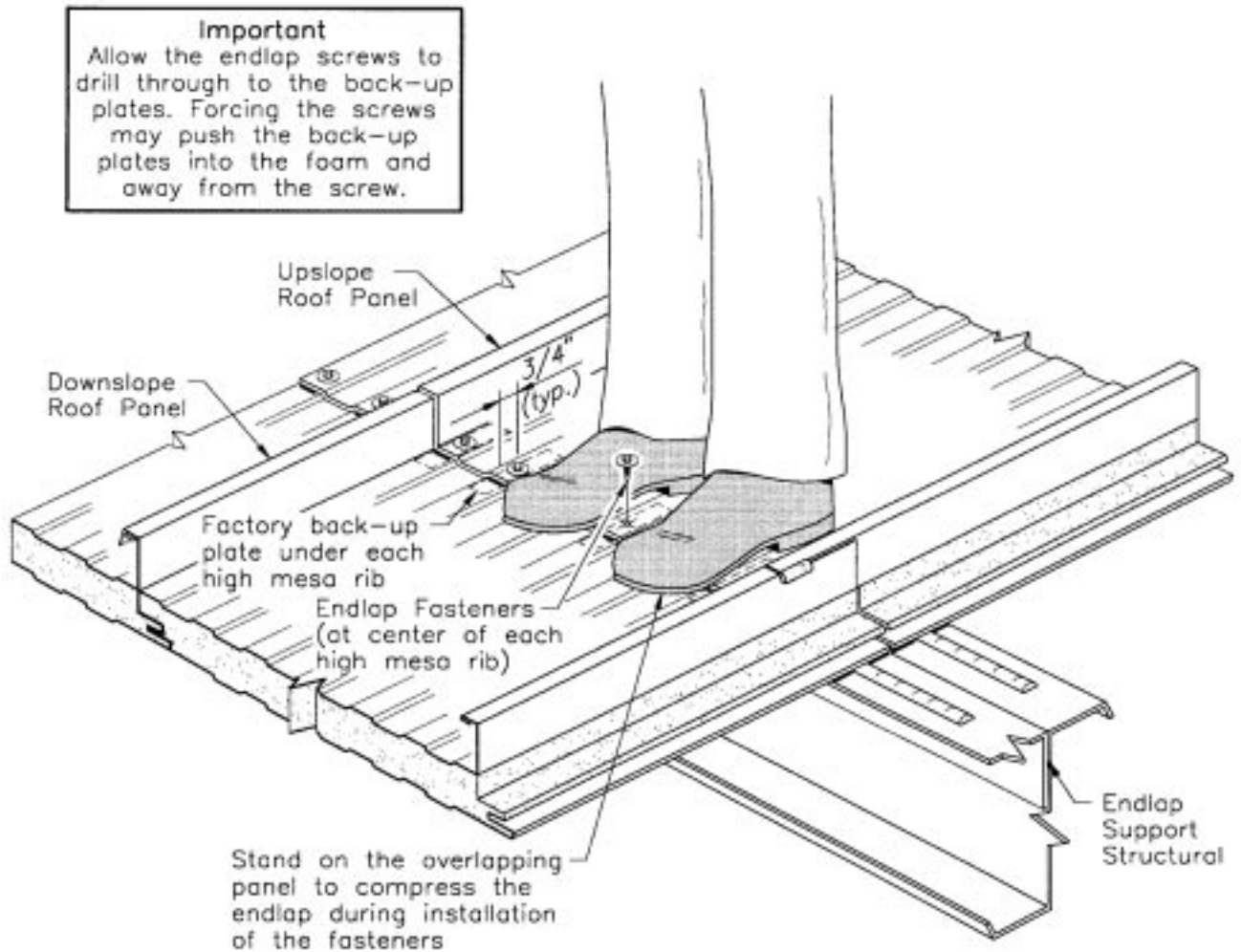

### Endlap Fastener Installation

1. Check that the upslope panel is completely nested into the downslope panel and that the endlap sealant is in full contact with both panel surfaces, especially at the corners.
2. Stand on the upslope panel's end to compress the endlap during installation of the endlap fasteners.
3. Install the endlap fasteners at the center of each high mesa rib and  $3/4$ " from the upslope panel's end. Check that the fasteners are penetrating the sealant.
4. Tighten the screws as necessary to assure uniform and complete contact of the endlap sealant to both panel surfaces.

## CFR-42 ROOF PANEL

C450.626

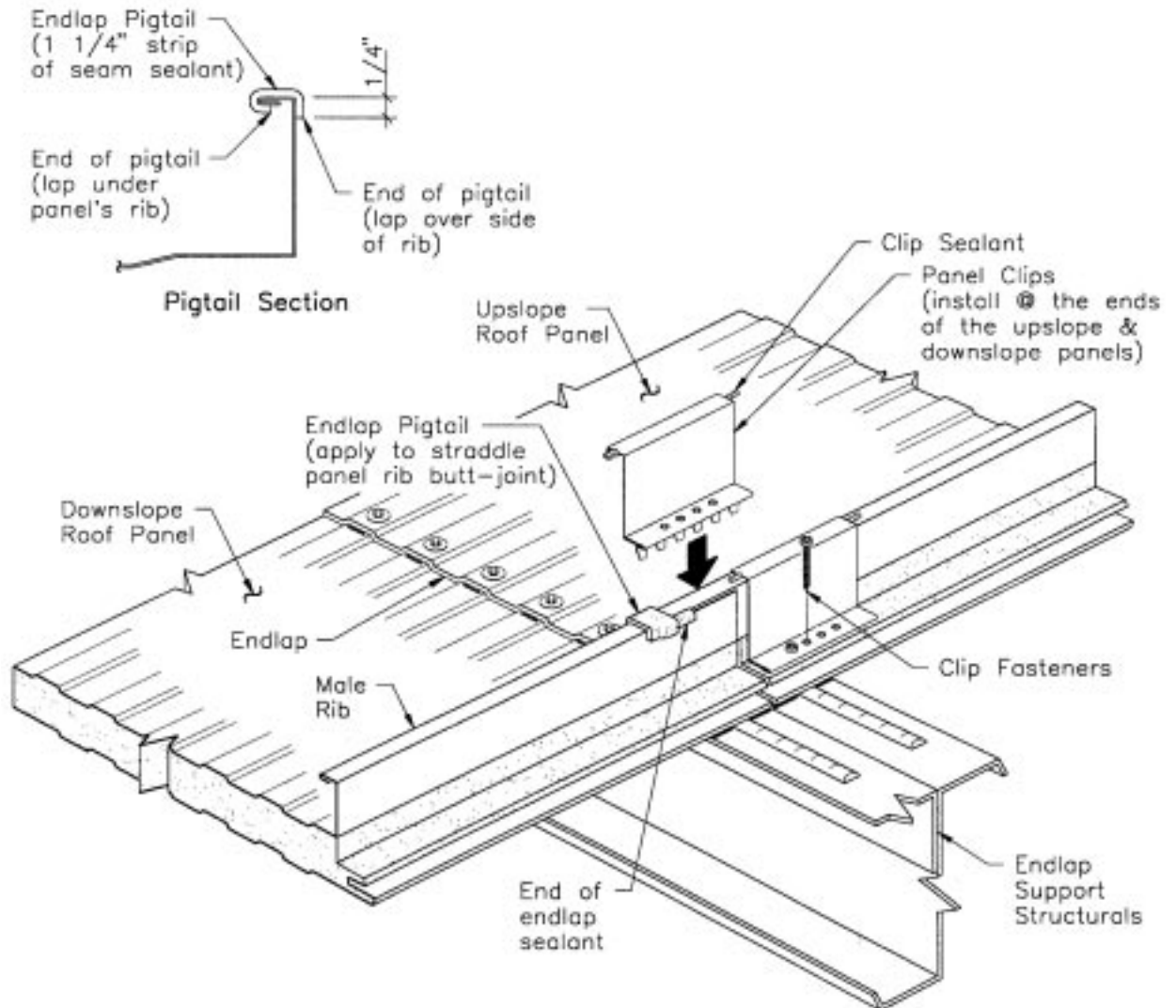

### Endlap Pigtail and Panel Clip Installation

1. Apply endlap pigtail to straddle the male rib's butt joint. Use 1 1/4" strip of seam sealant for pigtail. Lap one end of pigtail over the side of the rib. Lap the other end under the rib.
2. Install panel clips at the ends of the upslope and downslope panels. Position both clips so they can be fastened to the endlap support structural.
3. Install the clip fasteners through the clip's outer holes as necessary for attachment to the endlap support structural.
4. Crimp the clips over the panel's male ribs with the manual seaming tool.

## CFR-42 ROOF PANEL

C450.627

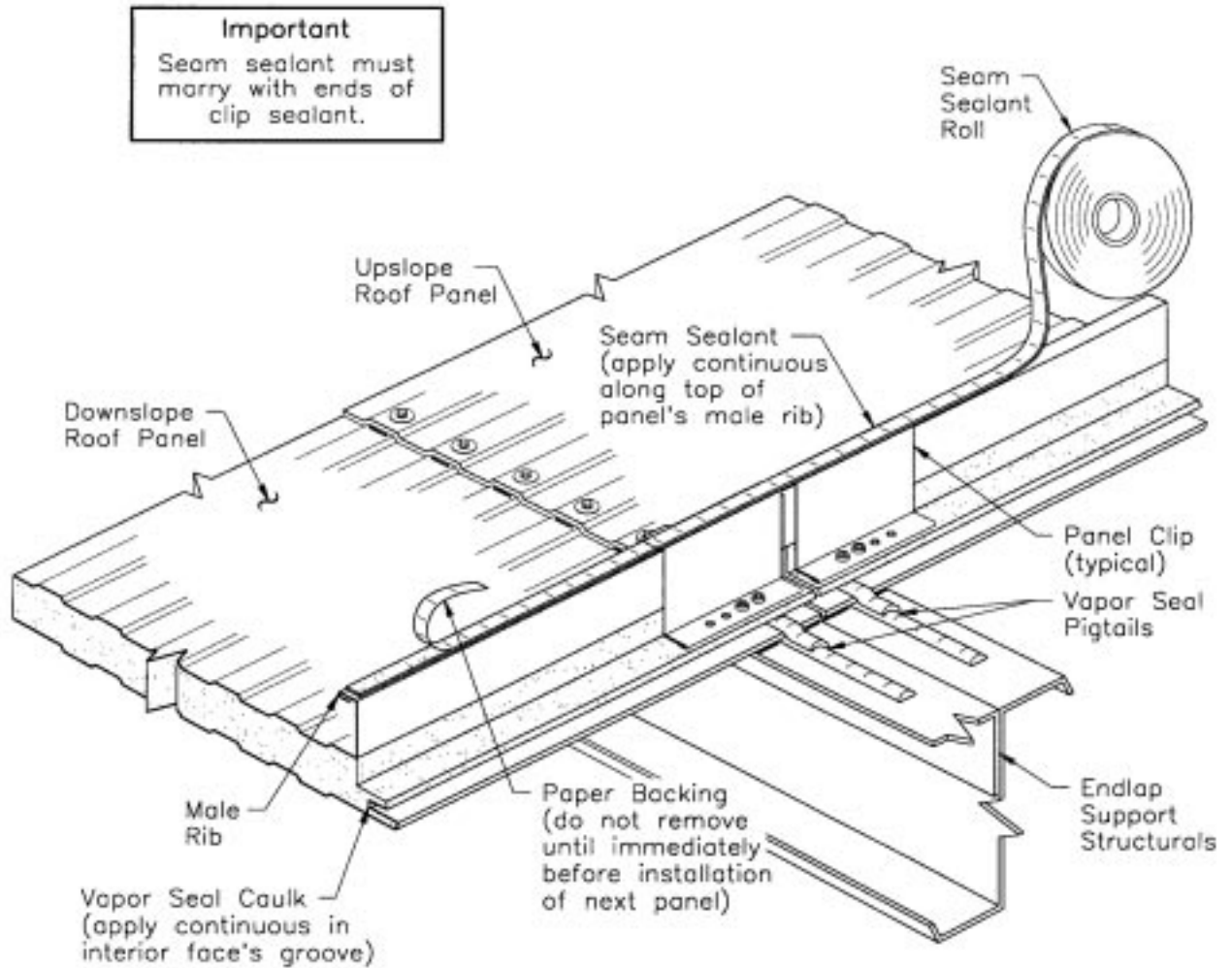

### Seam Sealant and Vapor Sealant Application

1. Apply seam sealant continuous along the top of the panel run's male rib. The seam sealant must marry with the clip sealant ends.
2. Apply vapor sealant caulk continuous in the panel's interior face groove.
3. Apply vapor seal pigtails to connect the vapor seal in the groove to the vapor seals on the endlap support structural.



## CFR-42 ROOF PANEL

C450.628

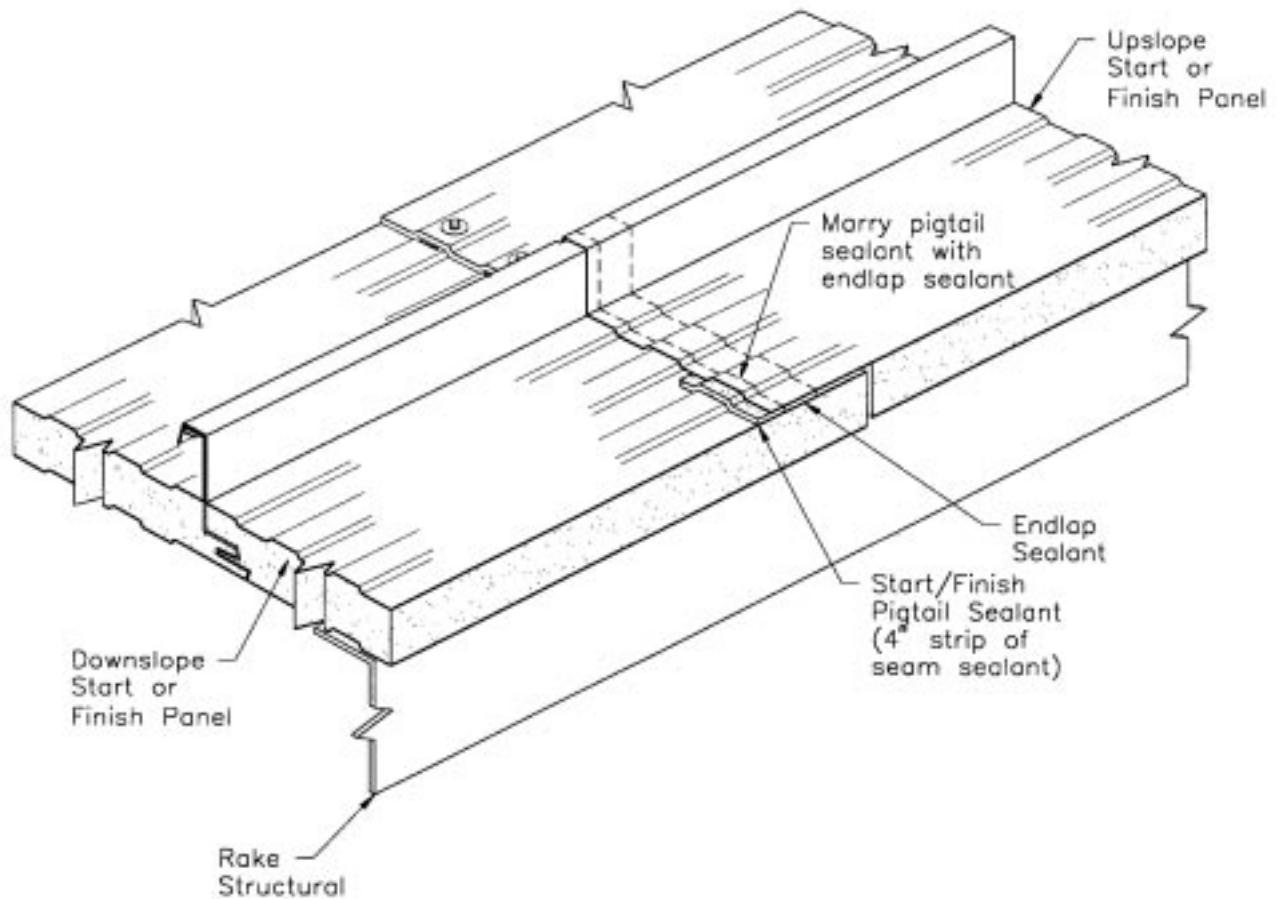

### Start/Finish Panel Pigtail Application (Finish Panel Shown, Start Panel Similar)

1. Before installing the upslope starting and finish panels, apply the start/finish pigtail sealant. Use a 4" long strip of seam sealant for the pigtail. Marry the edge of the pigtail sealant with the edge of the endlap sealant.
2. Check that the rake closure sealant will cross the pigtail sealant when the rake closure is installed.
3. Install the upslope starting or finish panel and cover the exposed pigtail sealant with it's paper backing until immediately before installation of the rake closure.

CFR-42 ROOF PANEL

C450.629

SECTION 3 – RAKE AND RIDGE CLOSURES INSTALLATION

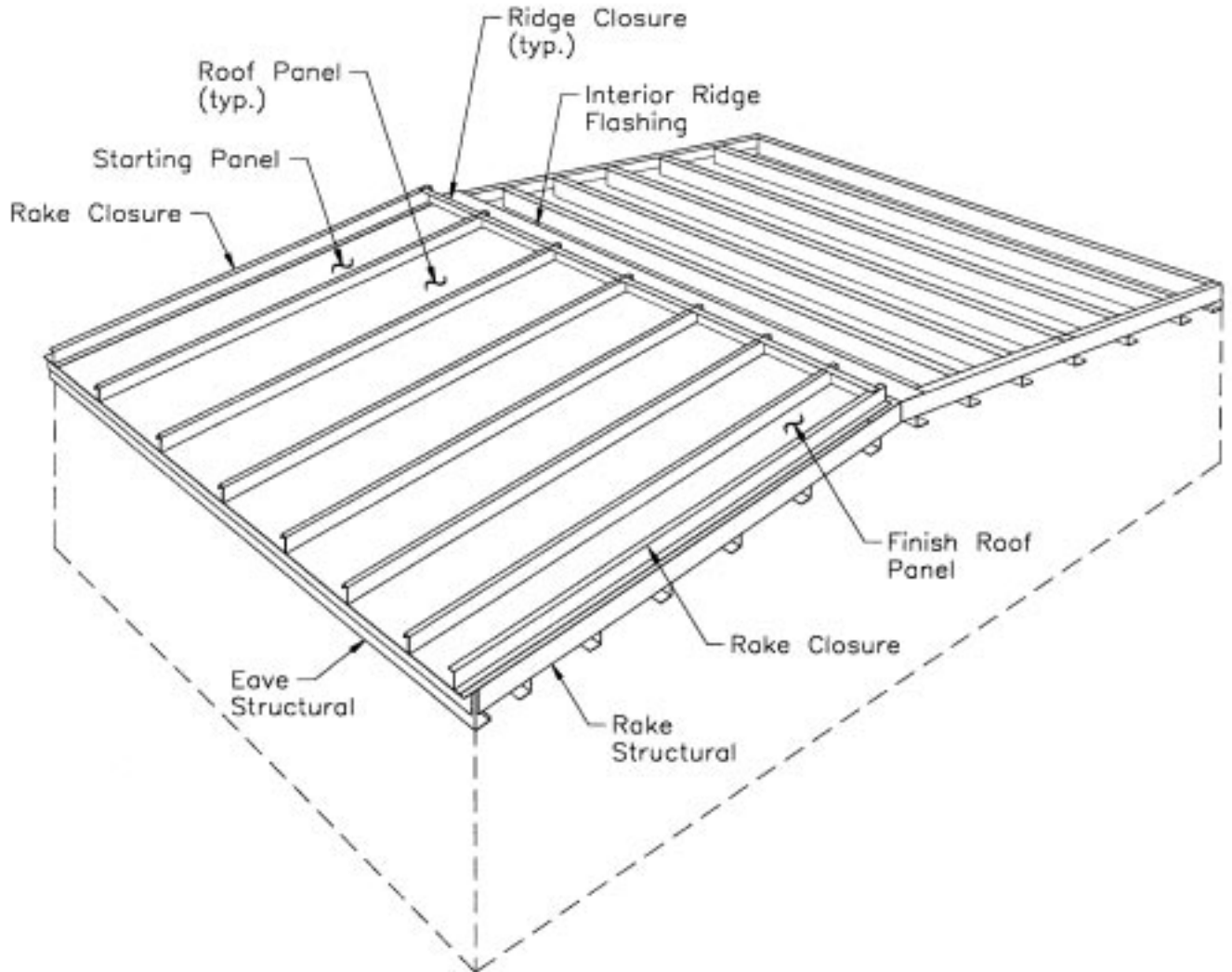

Typical Rake and Ridge Closures Installation

This section describes the installation of the rake and ridge closures for a typical roof with standard rake, ridge or high eave conditions.

Ridge conditions shown, high eave conditions are similar.



## CFR-42 ROOF PANEL

C450.630

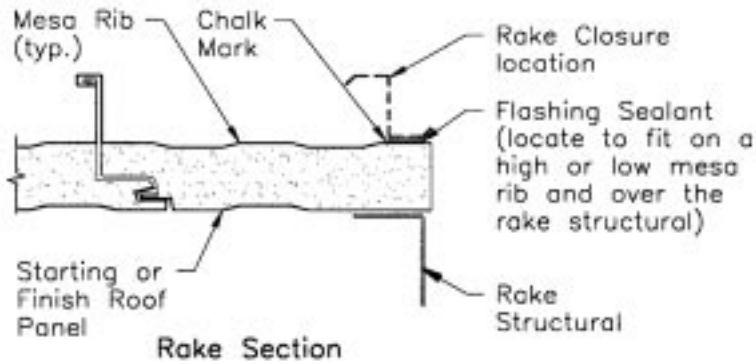

**Important**  
Roof panel and rake closure surfaces must be wiped clean and dry before sealant is applied.

**Caution**  
The sealant must be it's full thickness. Do not use flattened, pinched or stretched sealant.

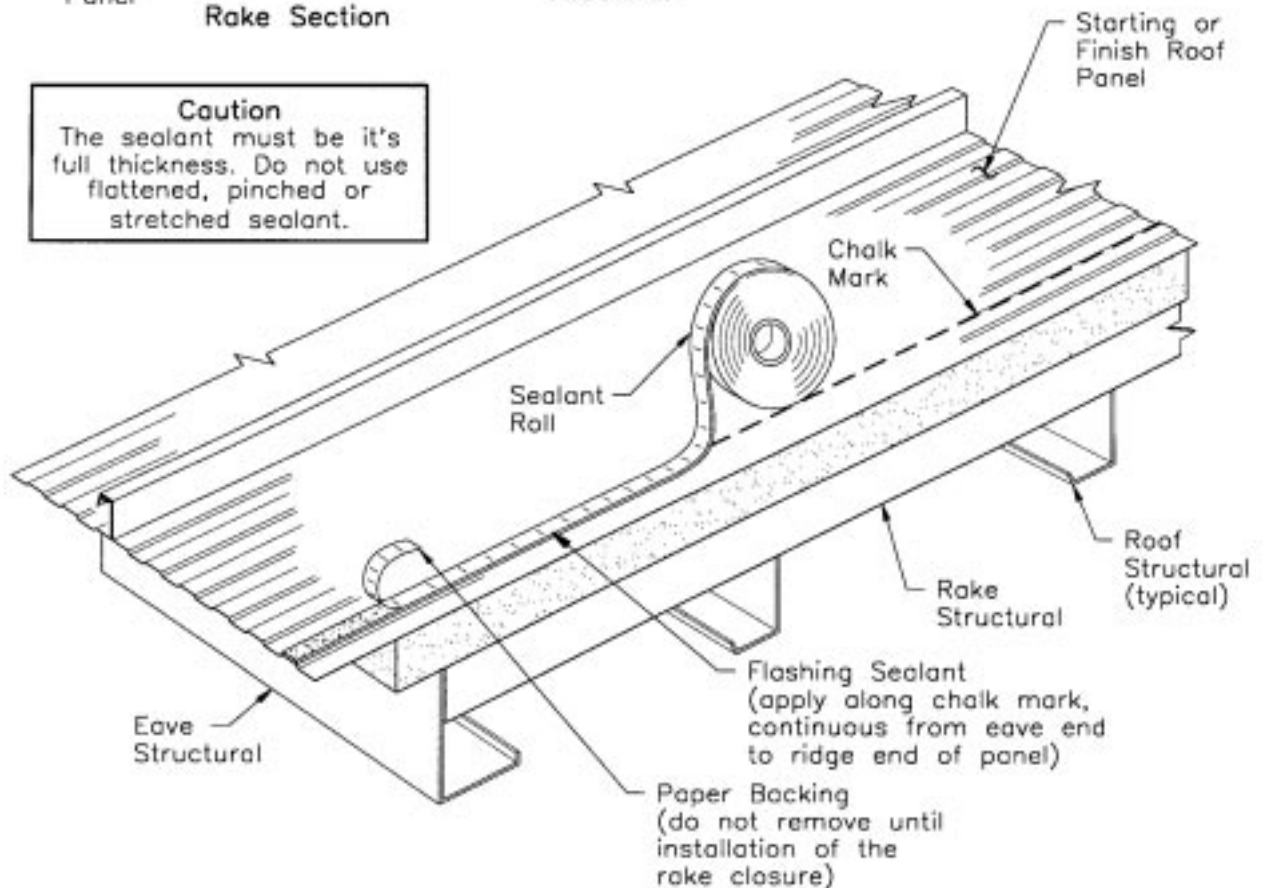

### Rake Closure Sealant Application

1. Determine the rake closure location on the starting and finish panels. The rake closure must set fully on a high or low mesa rib and must be positioned so the rake closure attachment screws will properly engage the rake structural. Note: The specific rake closure location may be shown on the job's installation drawings.
2. Mark the location for the rake closures face with a chalk line stretched from the eave end to the ridge end of the starting and finish panels.
3. Apply flashing sealant continuously from the eave end to the ridge end of the panel. Align the edge of the sealants paper backing with the chalk mark on the panel.

## CFR-42 ROOF PANEL

C450.631

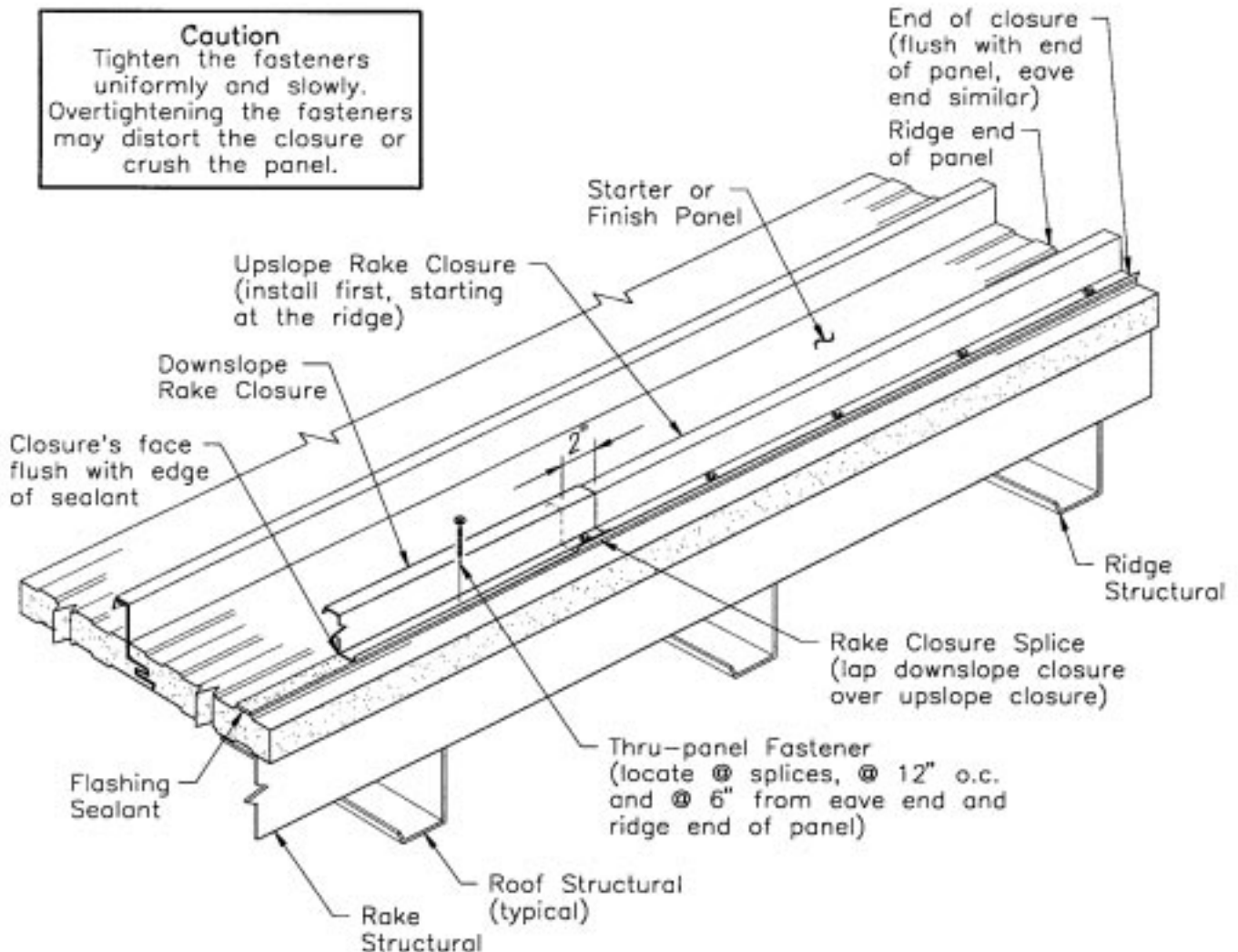

### Rake Closure Installation

1. To provide watershed laps at the rake closure splices, install the rake closures from the ridge to the eave. Start and finish the closures flush with the ridge and eave ends of the panel. Field cut the last closure to the required length.
2. Set the rake closure on the flashing sealant with the closure's face flush with sealant's edge.
3. Secure the rake closure with thru-panel fasteners located at the splices and at 12" o.c. Check that the fasteners penetrate through the center of the sealant and engages the rake structural.
4. Tighten fasteners as necessary to assure uniform and complete contact of sealant to the panel and rake closure surfaces.
5. See following Rake closure Splice Assembly detail.

## CFR-42 ROOF PANEL

C450.632

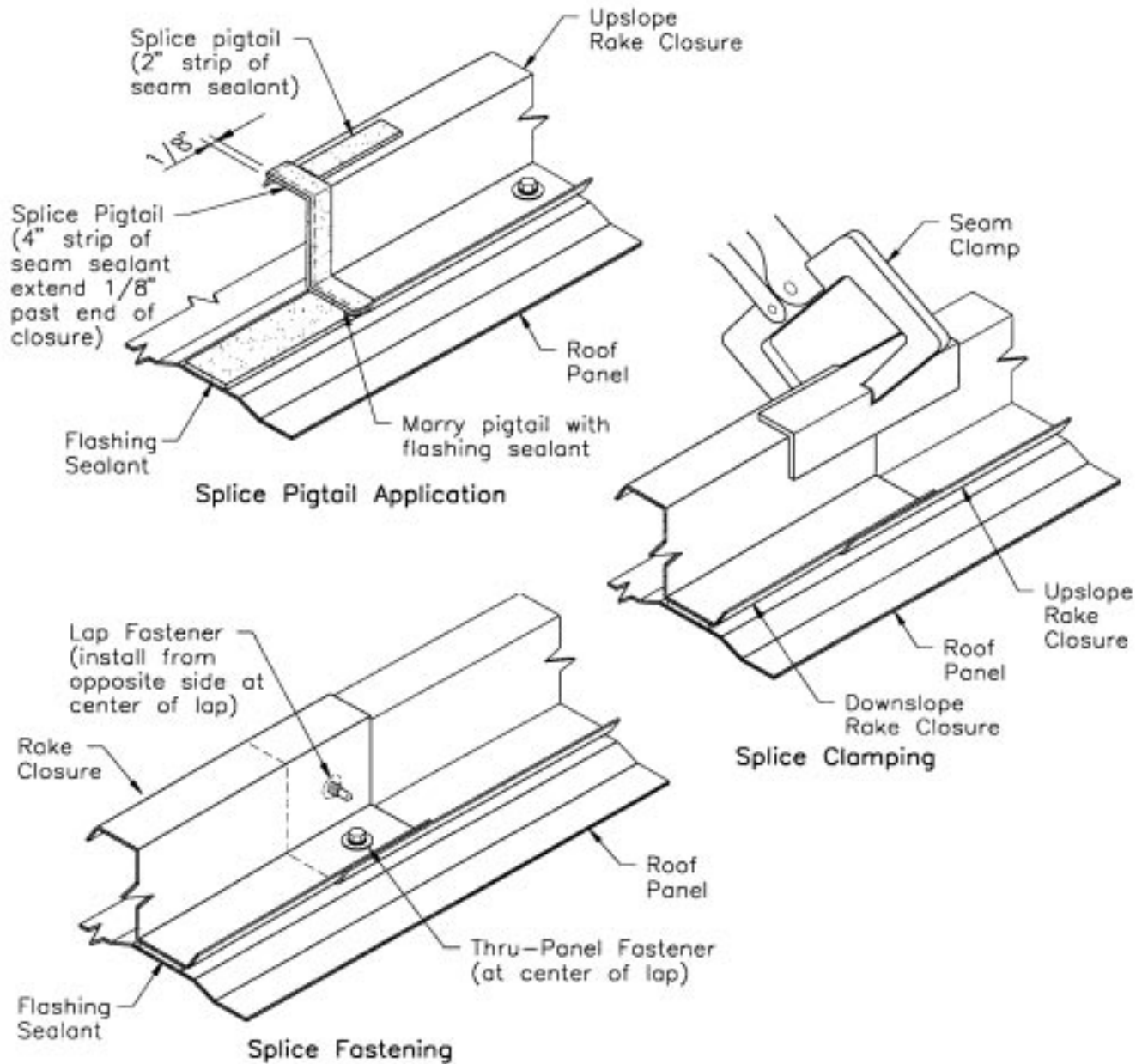

### Rake Closure Splice Assembly

1. Apply the splice pigtail on the end of the upslope rake closure. Use a 4" and a 2" long strip of seam sealant for the pigtails.
2. Position the edge of the pigtail 1/8" beyond the rake closure's end. Marry the bottom of the pigtail with the flashing sealant on the panel.
3. Compress the splice with seam clamps. In cold weather, close the clamp slowly to allow the sealant to flow and to avoid distortion of the closure.
4. Install a thru-panel fastener and a lap fastener through the splice. Install the lap fastener so its head and sealing washer are on the weather side of the rake closure.



## CFR-42 ROOF PANEL

C450.633

**Important**  
The ridge end of the panel seams must be crimped before installation of the ridge closure. Use the manual seamer tool.

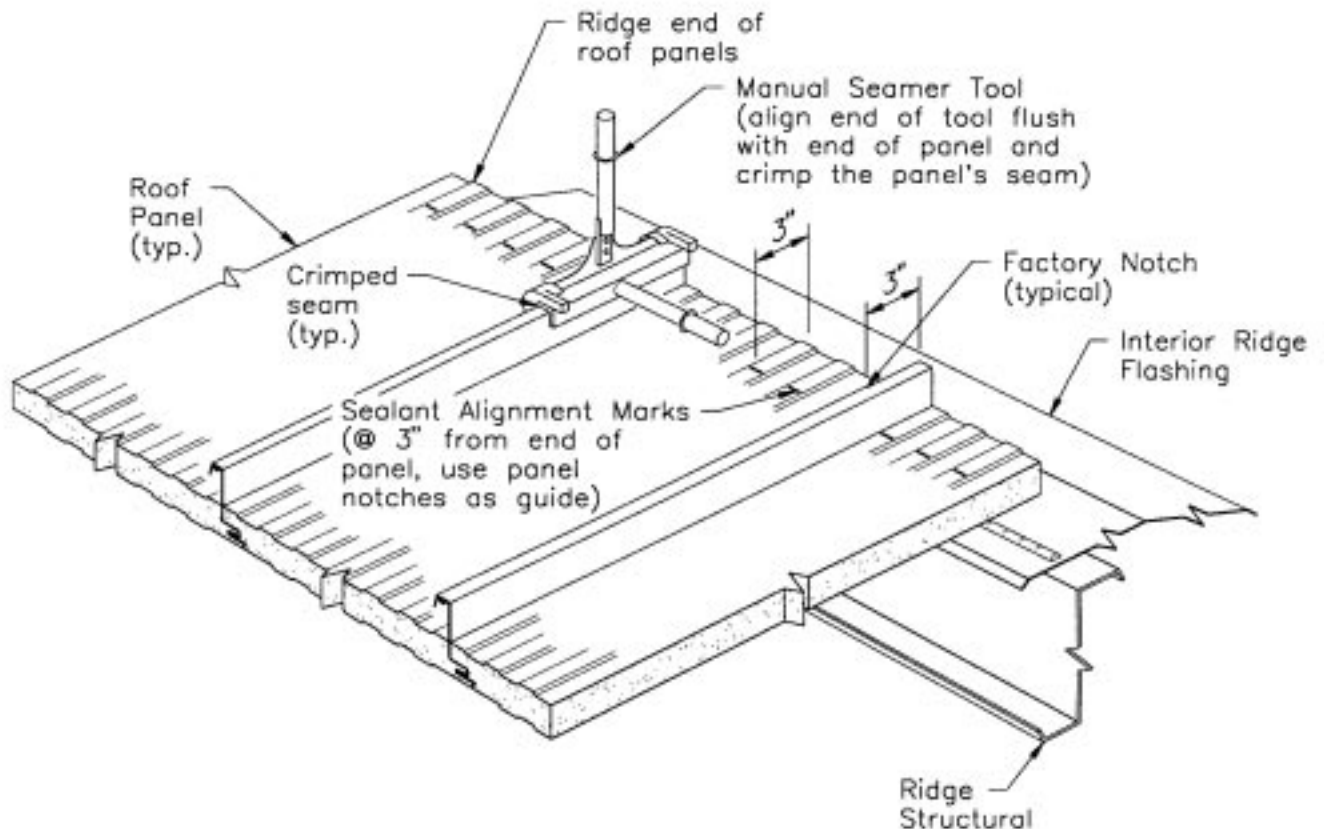

### Ridge Closure Preparation

1. Check that the ridge end of the roof panels are uniformly aligned within  $\pm 1/2"$ .
2. Layout and mark the endlap sealant location at 3" from the panel ends.
3. If the panel ends are not uniformly aligned, use a chalk line to establish a uniform sealant line which will accommodate the factory notches of the shortest roof panels.
4. Crimp the ridge end of the panel seams with the manual seamer tool before installing the sealant and ridge closures.

## CFR-42 ROOF PANEL

C450.634

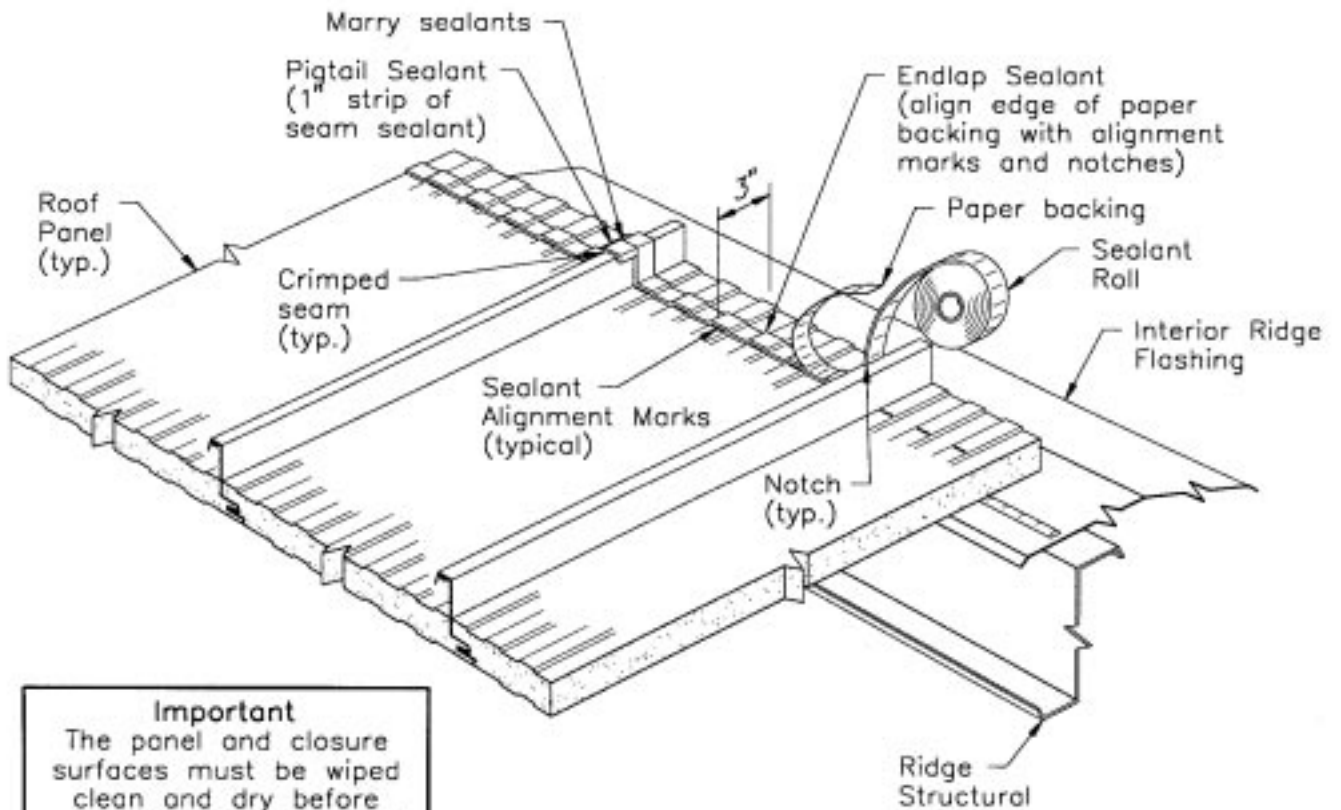
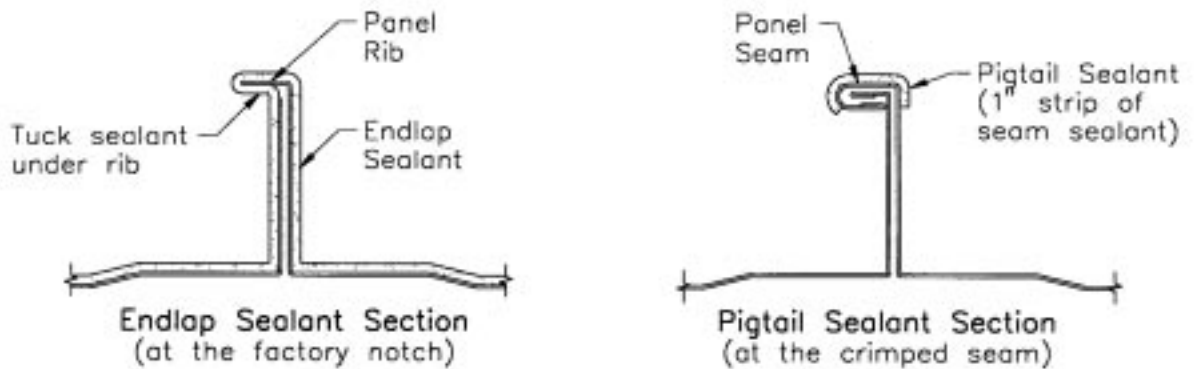

### Ridge Closure Sealant Application

1. Apply endlap sealant continuous across the panels. Align the edge of the sealant's paper backing with the alignment marks.
2. At the panel's sidelap, wrap the sealant under the panel's rib. The sealant's edge must be flush with the end of the factory notch.
3. At this time, check that all the panel's backer plates are in position. See Standard Roof Panel Description detail. Contact Metl Span for replacement plates and installation instructions.



## CFR-42 ROOF PANEL

C450.635

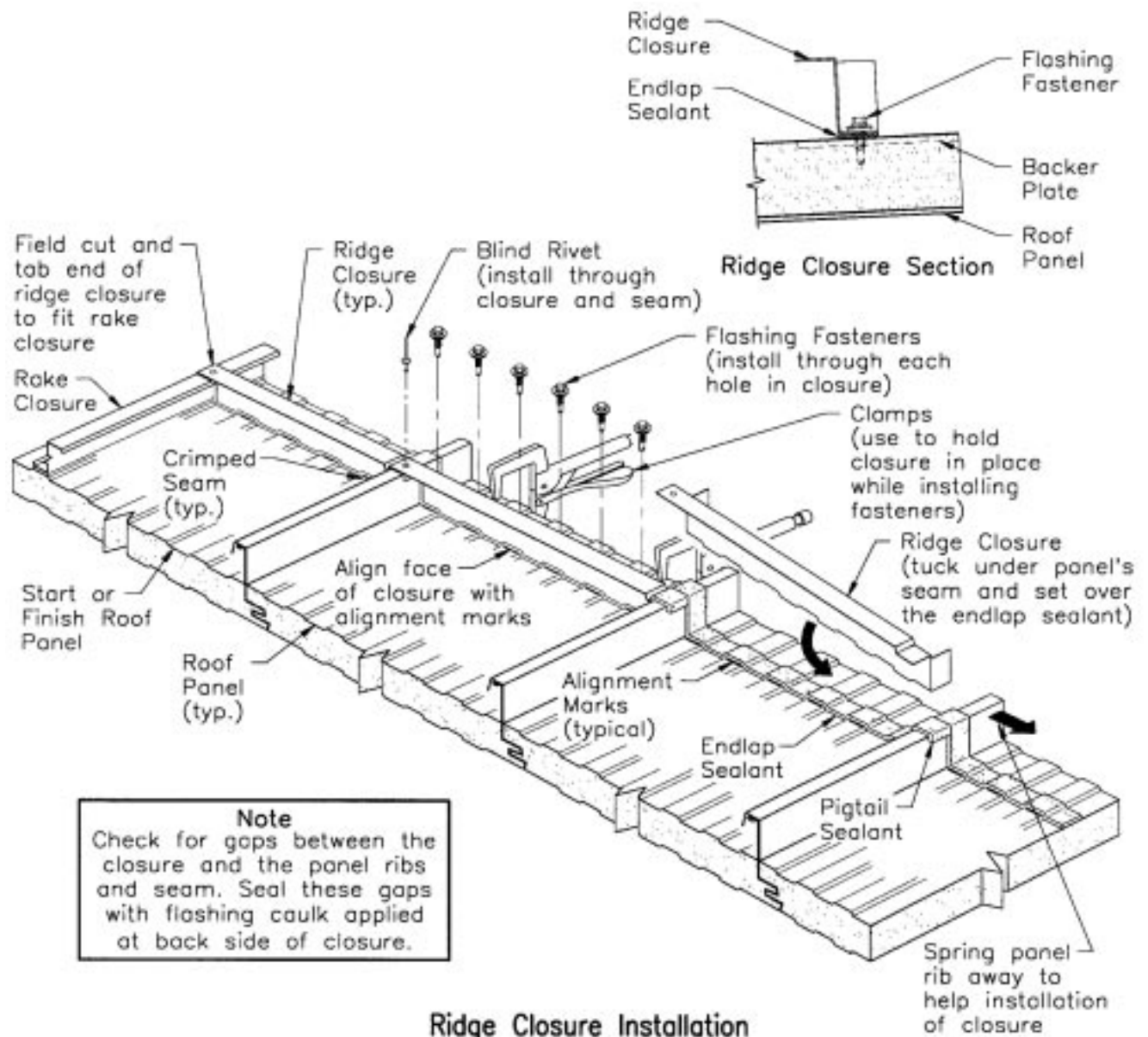

### Ridge Closure Installation

1. Tilt the ridge closure so its stepped end will slide under the roof panel's seam. Spring the panel rib outward to ease the installation of the closure. Check that the sealant is not displaced during the closure installation.
2. Align the face of the closure with the alignment marks. Check that the closure sits fully on the sealant. Use clamps to pull down and hold the closure during fastening.
3. Install the fasteners through each hole in the bottom flange of the closure. Check that the fasteners penetrate through the sealant and into the roof panel's backer plates. Tighten the fasteners as necessary to ensure uniform and complete contact of the sealant to the closure and panel surfaces.
4. Fasten the closure to the seam with a blind rivet.
5. At the rakes, field cut and tab the end of the ridge closure to fit with the rake closure. Fasten the tab to the rake closure with blind rivets.

## CFR-42 ROOF PANEL

C450.636

### SECTION 4 – TRIM AND FLASHING INSTALLATION

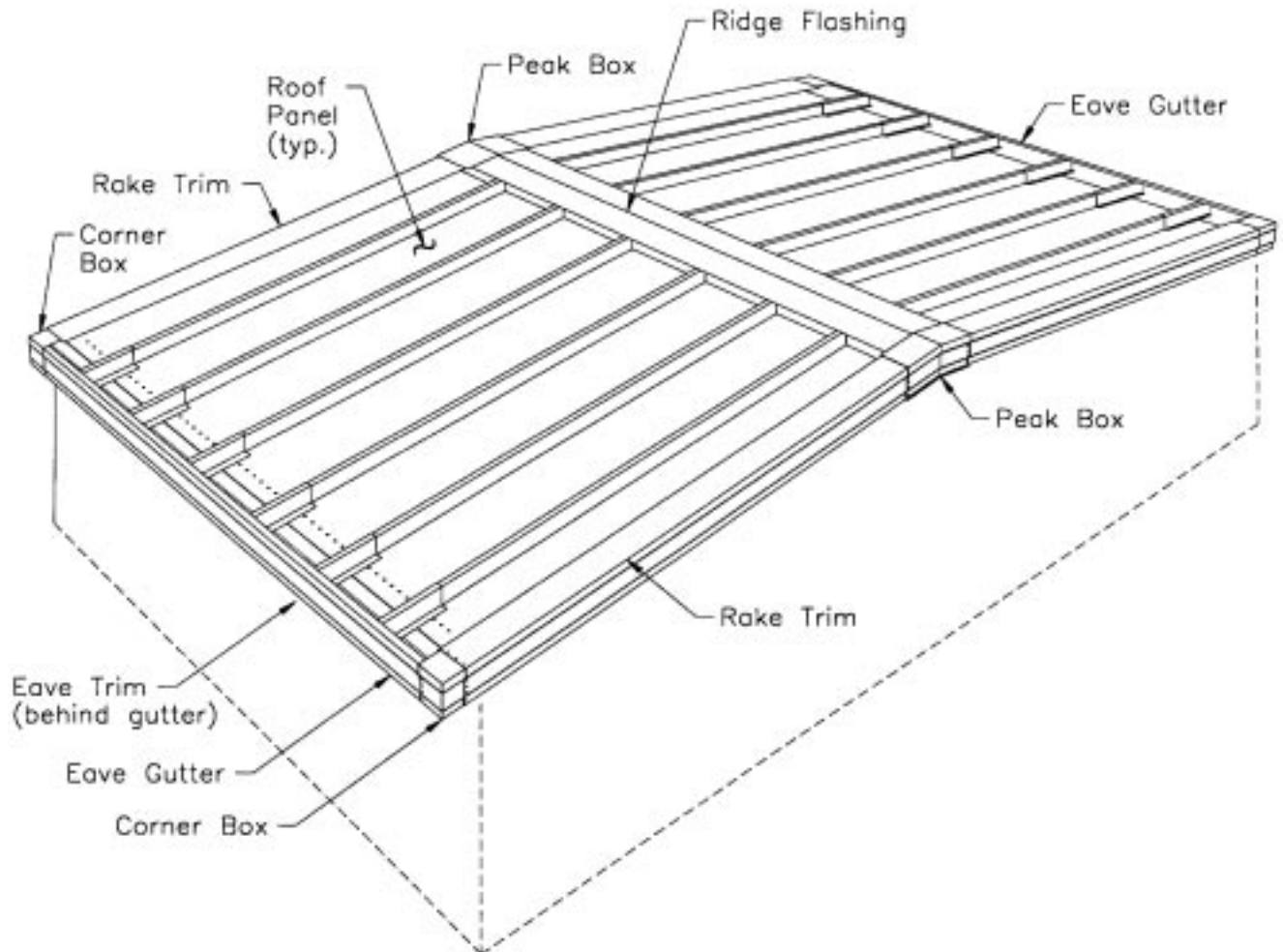

#### Typical Trim and Flashing Installation

This section describes the installation of the ridge flashing, rake trim, eave trim and eave gutter.

Installation of high side eave trim is similar.

See Transition Flashing Installation section for rake transition and high eave transition flashing installation.

For clarity of details, filler insulation is not shown. Refer to the job's installation drawings for filler insulation requirements.

## CFR-42 ROOF PANEL

C450.637

**Important**  
Install ridge flashing with  
a pitch  $1/2:12$  greater  
than the roof pitch.

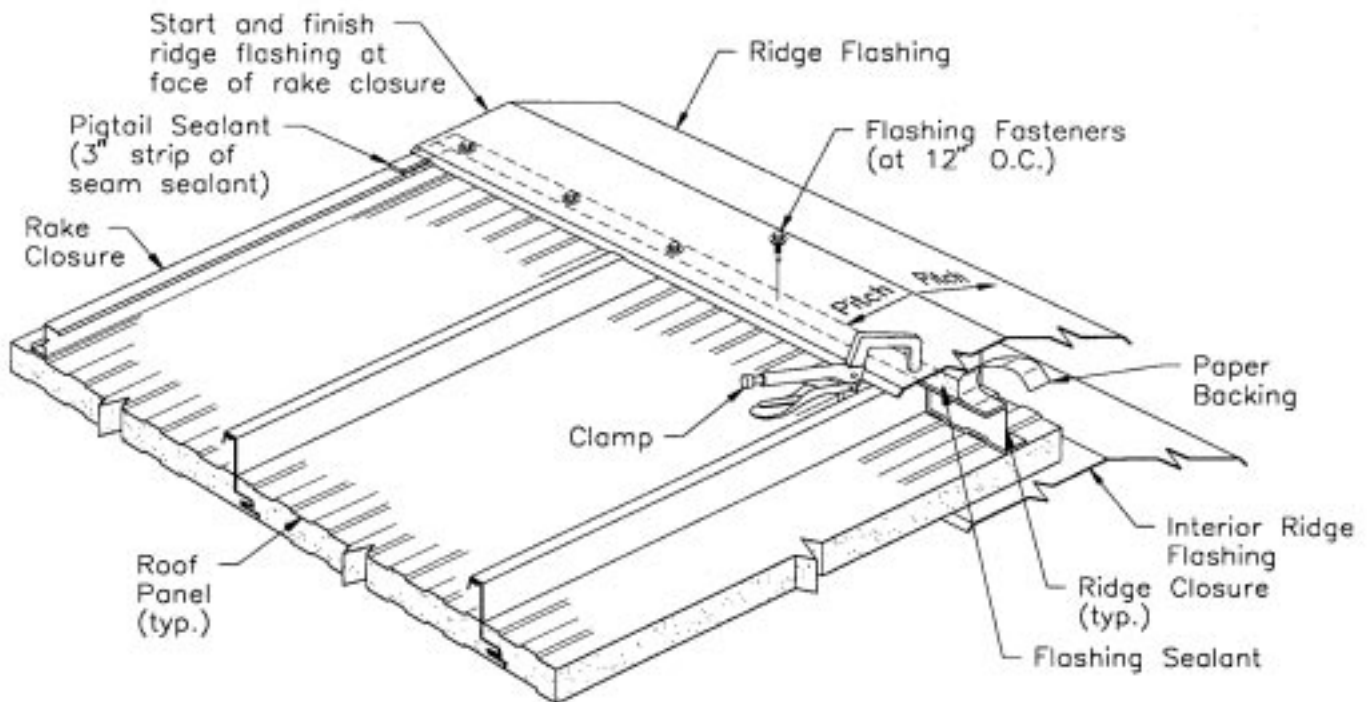

### Ridge Flashing Installation

1. Apply flashing sealant along the top of ridge closures. At the rakes, apply the pigtail sealant on top of the rake closure.
2. Center the ridge flashing over the ridge closures. Use a string line to assure a straight ridge run.
3. Set the ridge flashing in position and clamp to the ridge closures. Check that the flashing is set at a pitch  $1/2:12$  greater than the roof pitch. This will assure that the flashing will not sag during cold weather contraction.
4. Fasten the ridge flashing edges to the ridge closures with flashing fasteners at 12" O.C. Check that the fasteners penetrate the sealant.
5. At splices, lap the ridge flashings 2". Apply flashing sealant and pigtails to seal the splice and fasten with flashing fasteners at 2" O.C. Check that the splice is secured at it's proper pitch to prevent sagging of the finished splice.



## CFR-42 ROOF PANEL

C450.638

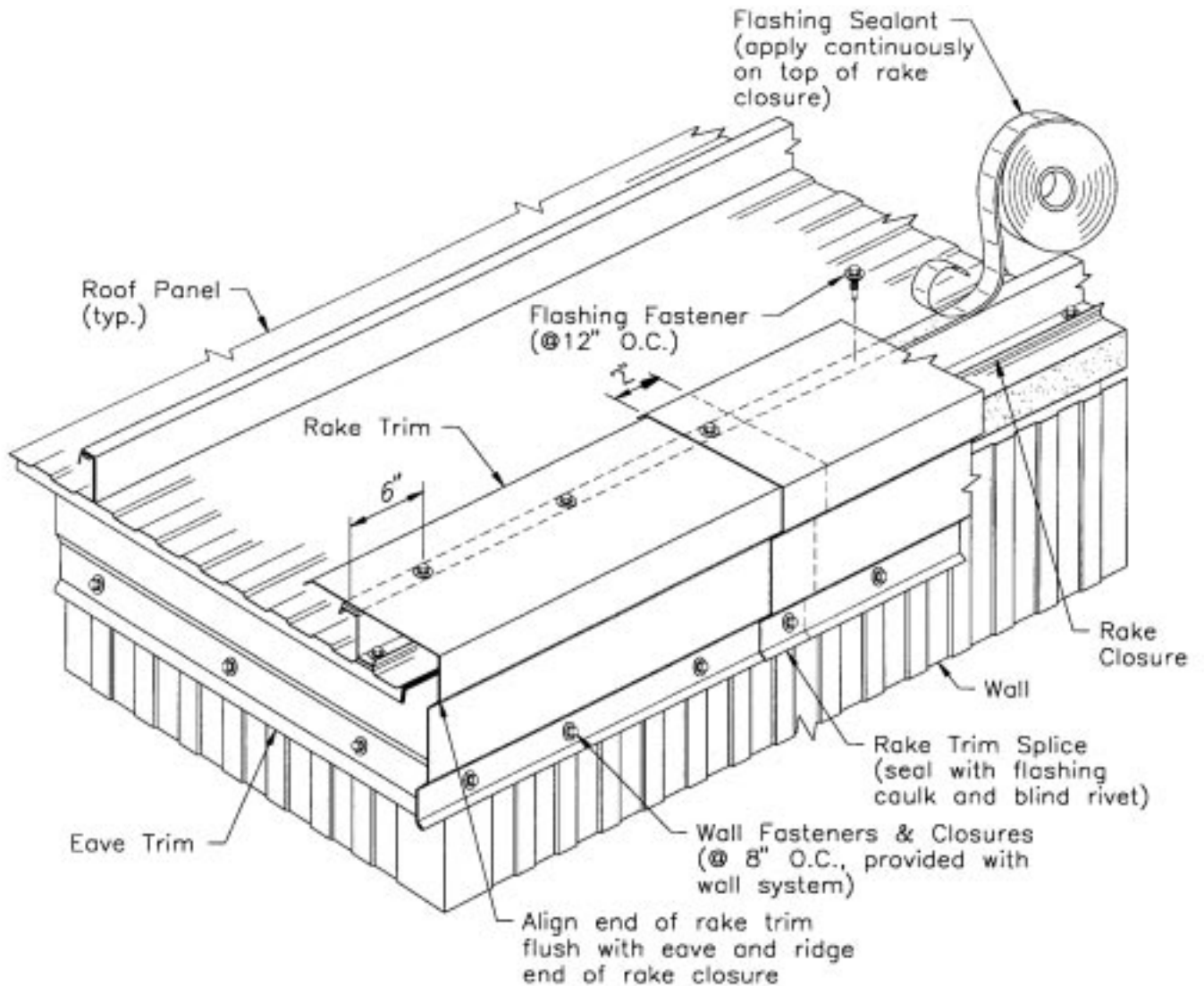

### Rake Flashing Installation

1. To ensure water shed of the rake trim splices, install the rake trim from the eave to the ridge.
2. Apply flashing sealant continuously along top of rake closure.
3. Align the ends of the rake trim flush with the eave and rake ends of the rake closure. Plumb and level the rake trim. Use string lines to ensure a straight rake trim run.
4. Fasten the rake trim to the rake closure with flashing fasteners at 12" O.C. Check that the fasteners penetrate the sealant.
5. At the rake trim splices, lap the rake trims 2". Seal and fasten the splice with flashing caulk and blind rivets.

## CFR-42 ROOF PANEL

C450.639

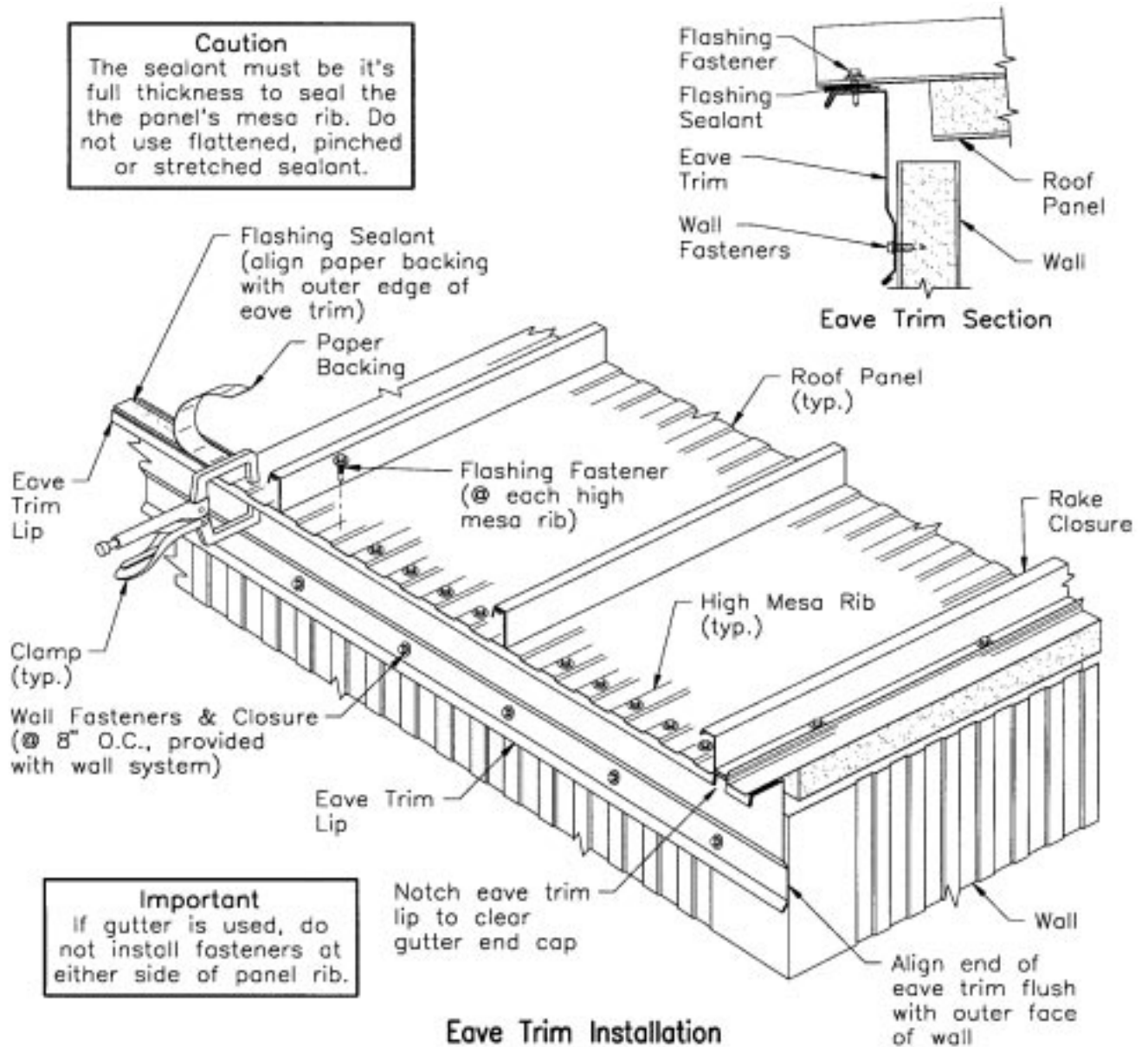

**Important**  
If gutter is used, do not install fasteners at either side of panel rib.

### Eave Trim Installation

1. If gutter is to be used, notch eave trim's lip to clear gutter end cap.
2. Apply flashing sealant continuously along top of eave trim. Align edge of sealant's paper backing with outer edge of eave trim.
3. Align end of eave trim with outer face of wall. Plumb the eave trim and temporarily clamp to roof panel.
4. Fasten the eave trim to the roof panel with flashing fasteners. Install the fasteners at every high mesa rib of the roof panel. Note: if eave gutter is to be used, do not install fasteners at the mesa rib on either side of the panel ribs.
5. Tighten the fasteners as necessary to ensure uniform and complete contact of the sealant. Check that the sealant completely seals the panel's mesa ribs.
6. At eave trim splices, lap the trim 2". Seal with flashing caulk and fasten with blind rivets.



## CFR-42 ROOF PANEL

C450.640.1

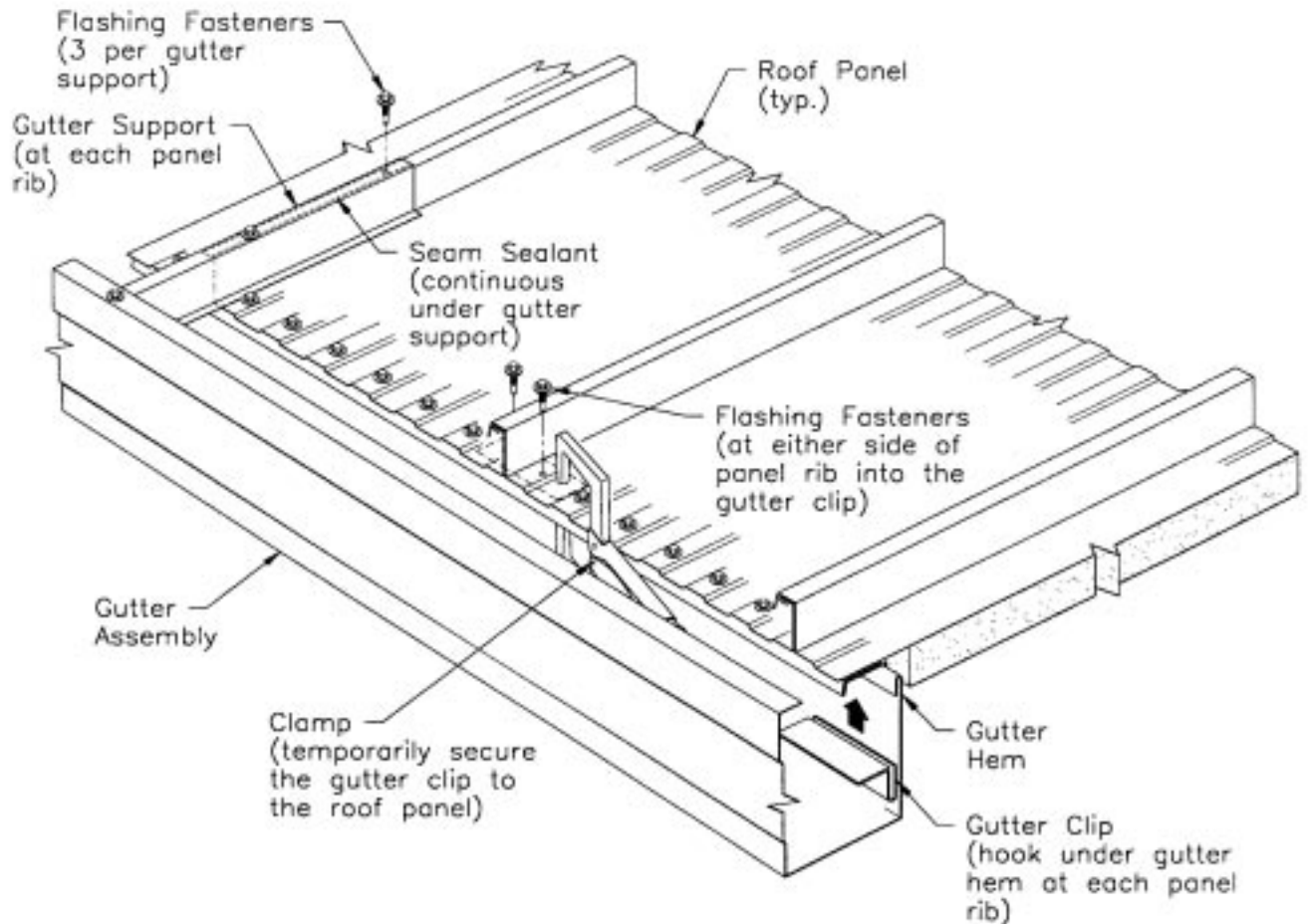

### Eave Gutter Installation

1. Slide a gutter clip up into the gutter's hem at each roof panel rib location.
2. Lift the gutter assembly into position under the eave trim. Temporarily clamp the gutter clips to the roof panel.
3. Fasten the gutter clips to the roof panel with a fastener at either side of the roof panel rib. Check that the fastener's threads engage the gutter clip.
4. Plumb the outer face of the gutter perpendicular to the roof pitch. Use a string line to ensure a straight gutter run.
5. Apply continuous strip of sealant to the under side of the gutter supports.
6. Install the gutter supports at each panel rib. Fasten the support to the panel rib and the gutter's outer lip.

## CFR-42 ROOF PANEL

C450.641

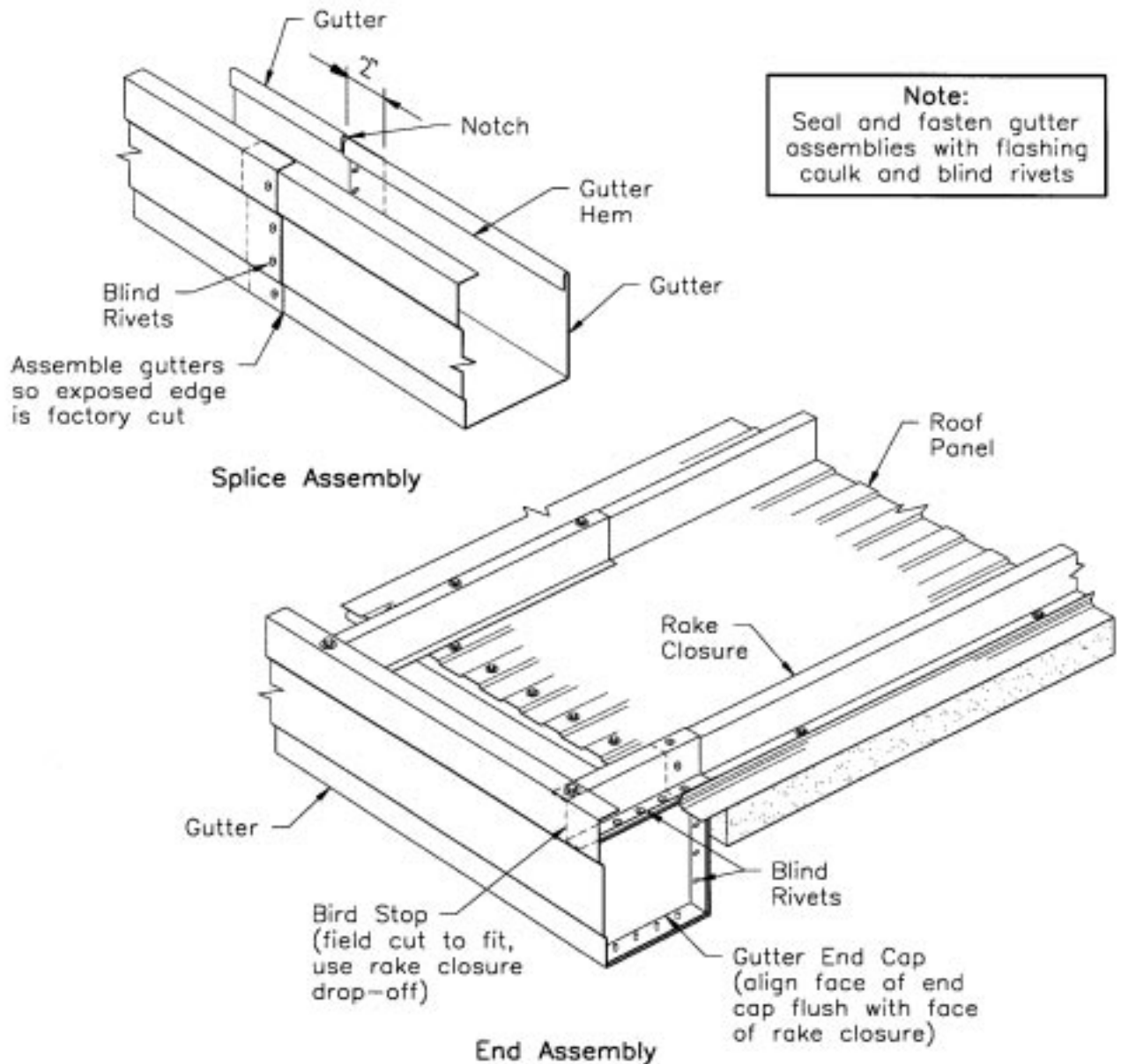

### Gutter End and Splice Assemblies

1. At the rakes, align the face of the gutter end cap flush with the face of the rake closure. Seal and fasten the end stops to the gutter.
2. Field cut rake closure drop-off to be used as the bird stops. Seal and fasten the bird stop to the top of the gutter end cap and to the rake closure.
3. At gutter splices, lap the gutters 2". Field notch the overlapping gutter's hem to clear the lap.
4. Seal and fasten the gutter assemblies with flashing sealant and blind rivets.

## CFR-42 ROOF PANEL

C450.642

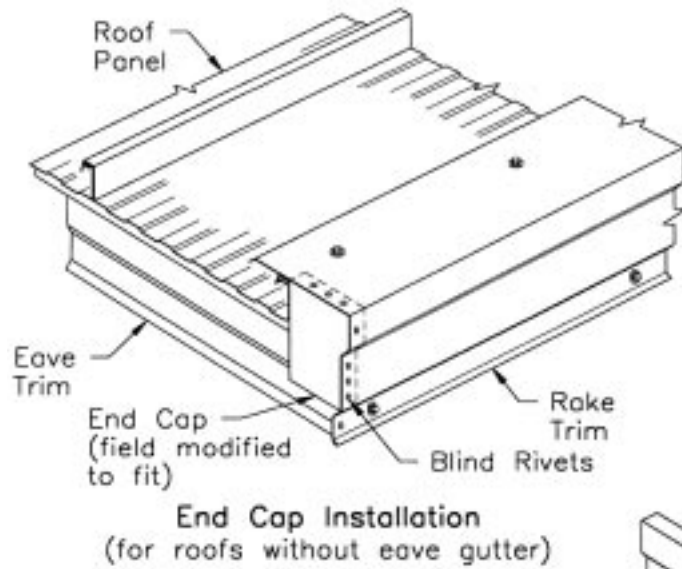

**Note**  
Seal and fasten cap assemblies with flashing caulk and blind rivets

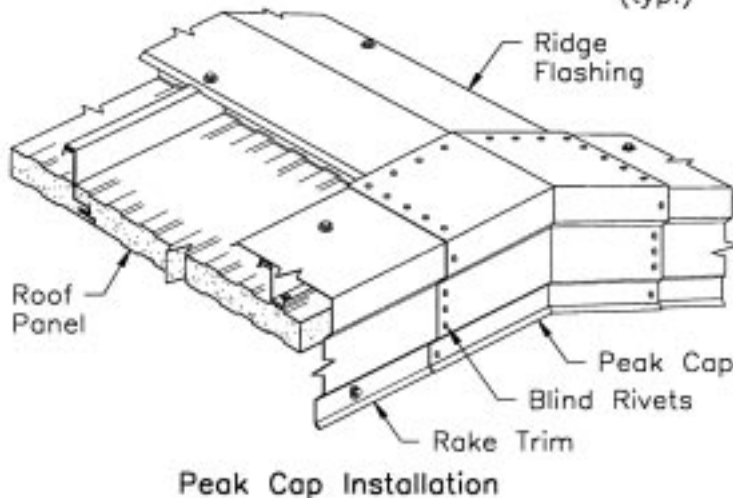
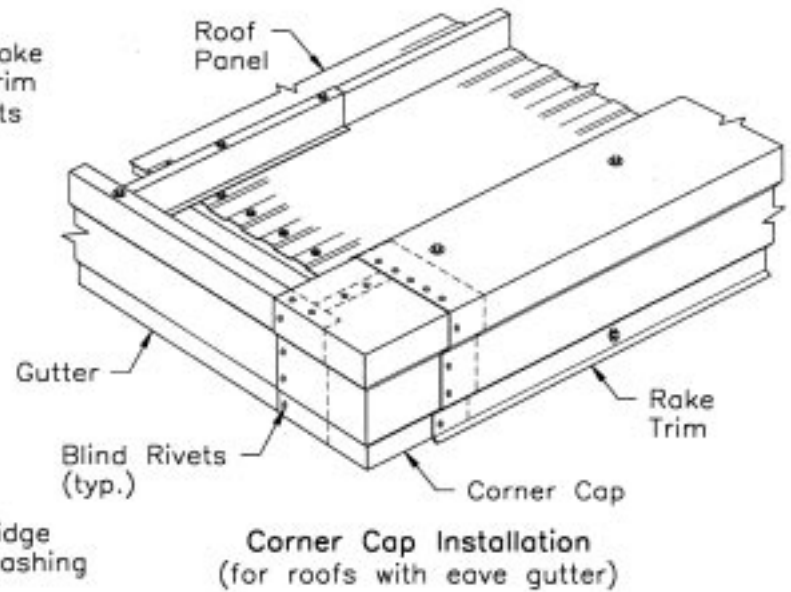

### Corner and Peak Cap Assemblies

1. For roofs without eave gutter, install the end cap inside the eave end of the rake trim.
2. For roofs with eave gutter, install the corner cap inside the eave end of the rake trim and over the end of the gutter.
3. For roofs with a ridge condition, install the peak cap over the ridge ends of the rake trim.
4. Seal and fasten assemblies with flashing caulk and blind rivets.

CFR-42 ROOF PANEL

C450.643

## SECTION 5 – TRANSITION FLASHING INSTALLATION

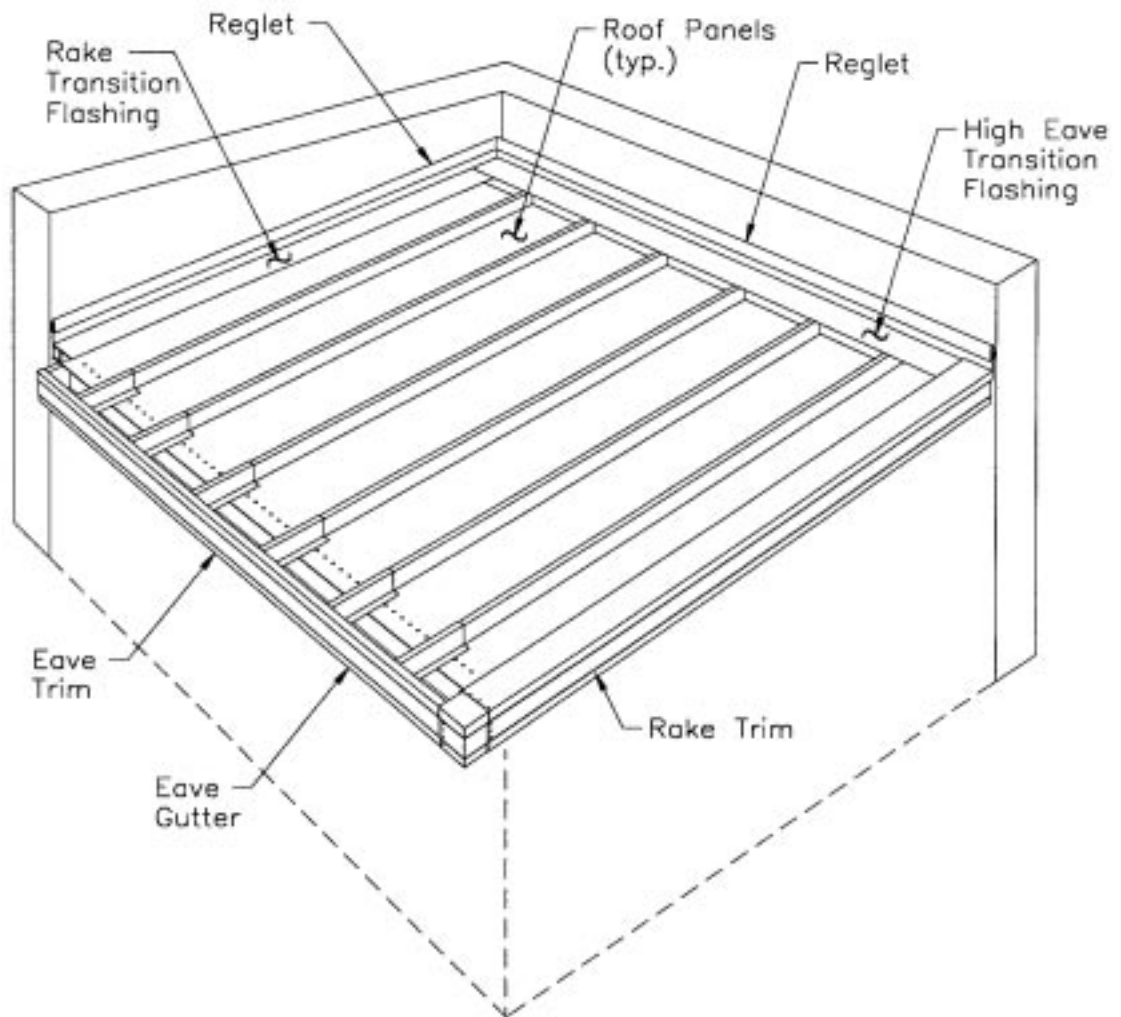

### Typical Transition Flashing Installation

This section describes the installation of the high side transition flashing and rake transition flashing.

For clarity of details, filler insulation is not shown. Refer to the job's installation drawings for filler insulation requirements.



## CFR-42 ROOF PANEL

C450.644

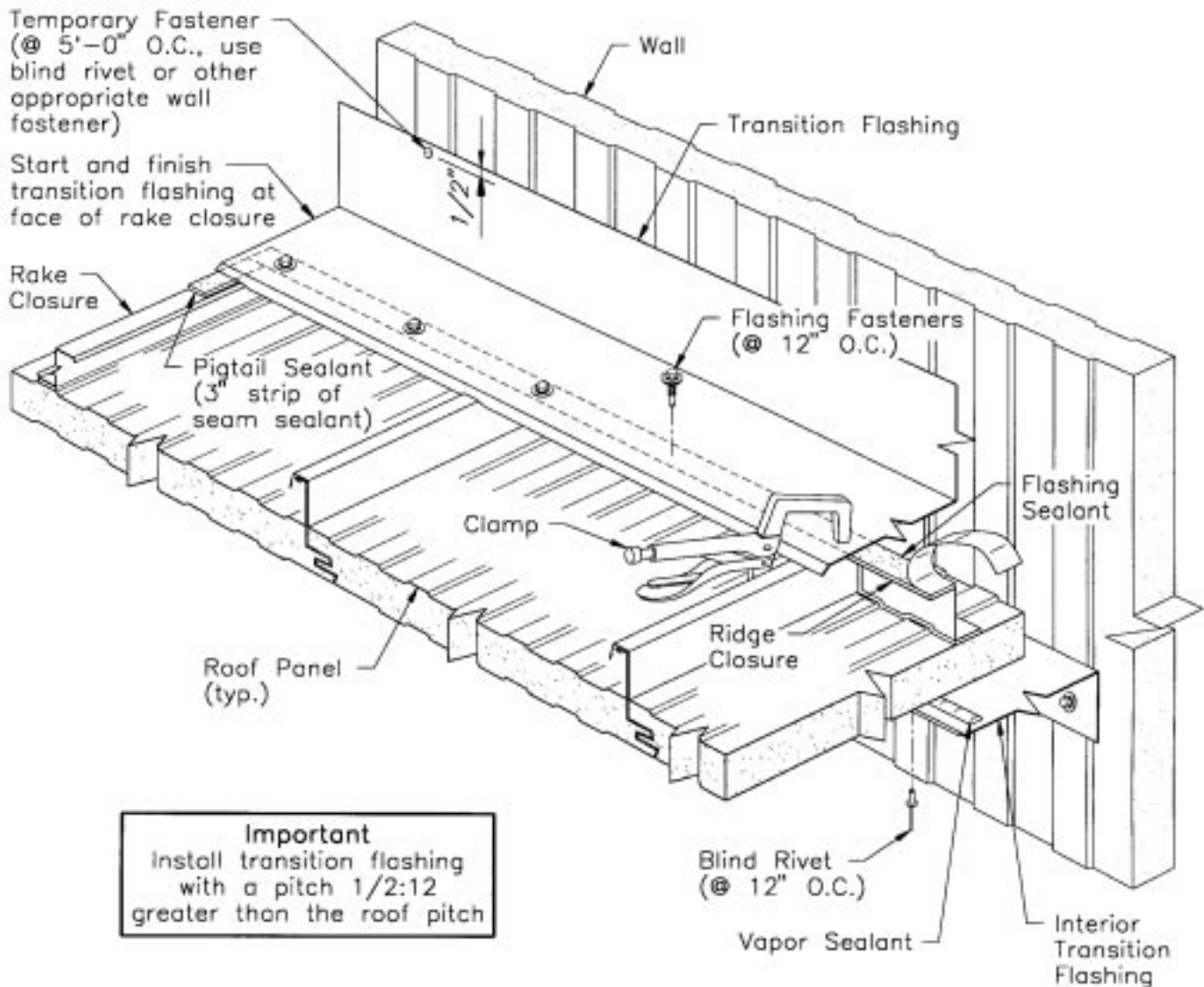

### High Side Transition Flashing Installation

1. Apply flashing sealant along the top of the ridge closures. At the rakes, apply the pigtail sealant on top of the rake closure.
2. Set the transition flashing in position and clamp to the ridge closures. Check that the flashing is set at a pitch  $1/2:12$  greater than the roof pitch. Temporarily fasten the top edge of the flashing to the wall.
3. Fasten the flashing to the ridge closures with flashing fasteners at 12" O.C. Check that the fasteners penetrate the sealant.
4. At splices, lap the ridge flashings 2". Apply flashing sealant and pigtails to seal the splice and fasten with flashing fasteners at 2" O.C. Check that the splice is secured at its proper pitch to prevent sagging of the finished splice.



## CFR-42 ROOF PANEL

C450.645

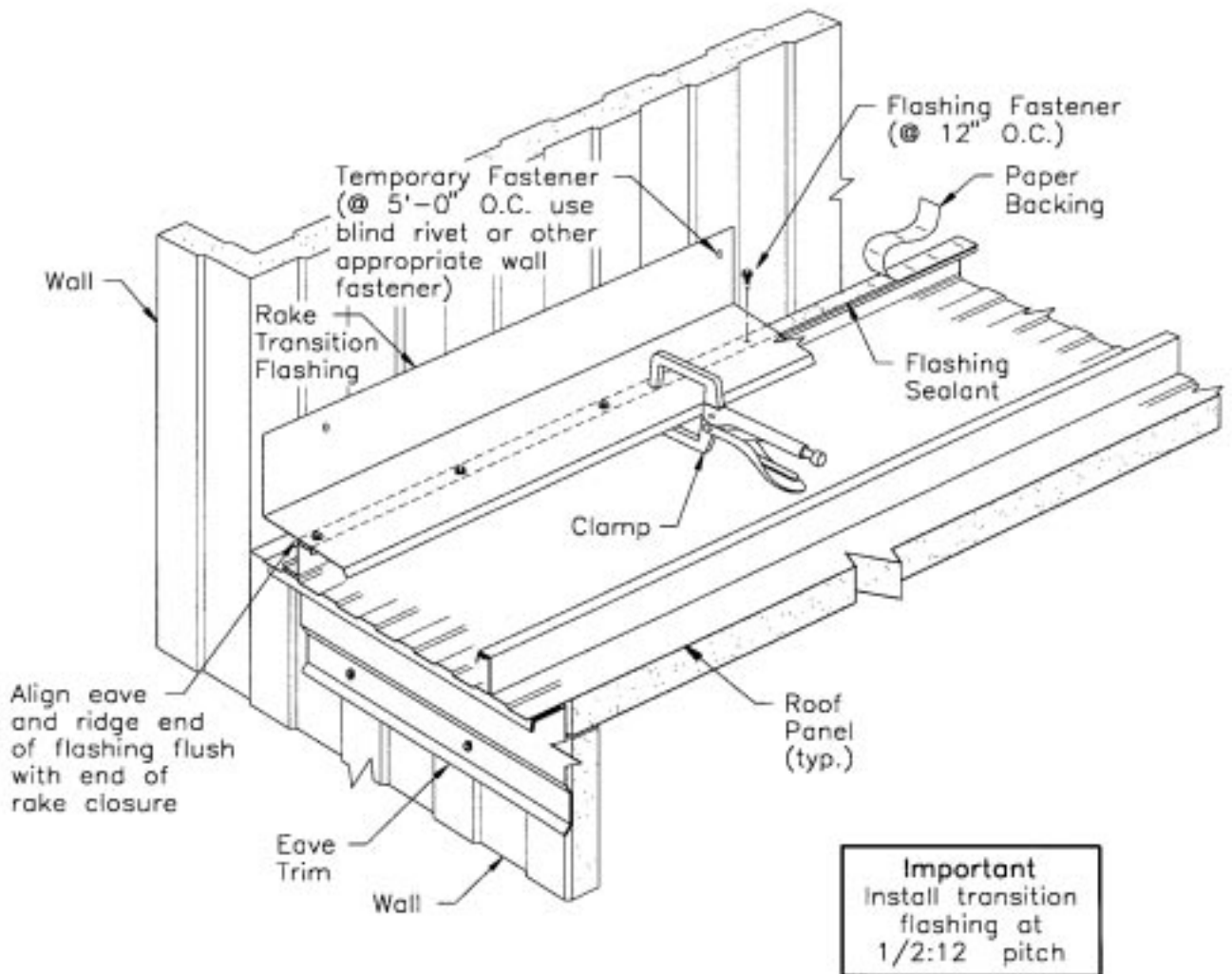

### Rake Transition Flashing Installation

1. Apply flashing sealant along the top of the ridge closure. At the ridge or high side condition, continue the sealant over the end of the ridge or high side flashing.
2. Set the rake flashing in position and clamp to the rake closure. Check that the flashing is set at a 1/2:12 pitch. Temporarily fasten the top edge of the flashing to the wall.
3. Fasten the ridge flashing to the ridge closures. Check that the fasteners penetrate the sealant.
4. At splices, lap the ridge flashings 2". Apply flashing sealant and pigtails to seal the splice and fasten with flashing fasteners at 2" O.C. Check that the splice is secured at it's proper pitch to prevent sagging of the finished splice.

## CFR-42 ROOF PANEL

C450.646

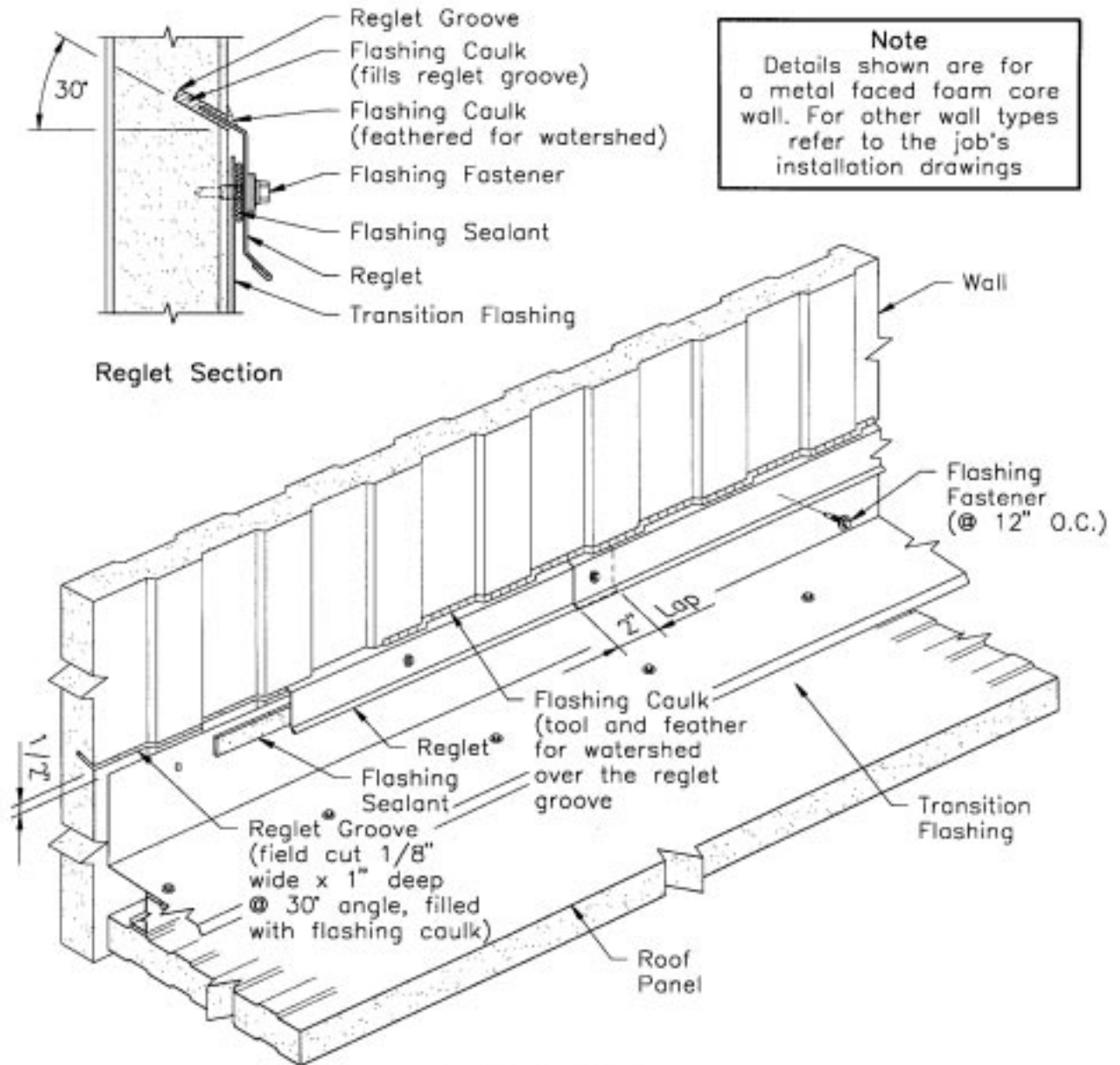

### Reglet Installation

1. Use chalk line to layout reglet groove along the wall at 1/2" above the transition flashing.
2. Field cut a continuous 1/8" wide x 1" deep groove into the walls outer face. Cut groove to angle upward at 30° from horizontal.
3. Fill the groove completely with flashing caulk.
4. Apply flashing sealant along the top edge of the transition flashing.
5. Insert the reglet's top edge into the groove.
6. Fasten the reglet to the wall with flashing fasteners.
7. Apply a bead of flashing caulk along the top of the reglet to wall junction. Tool and feather this bead to form a watershed.

## CFR-42 ROOF PANEL

C450.647

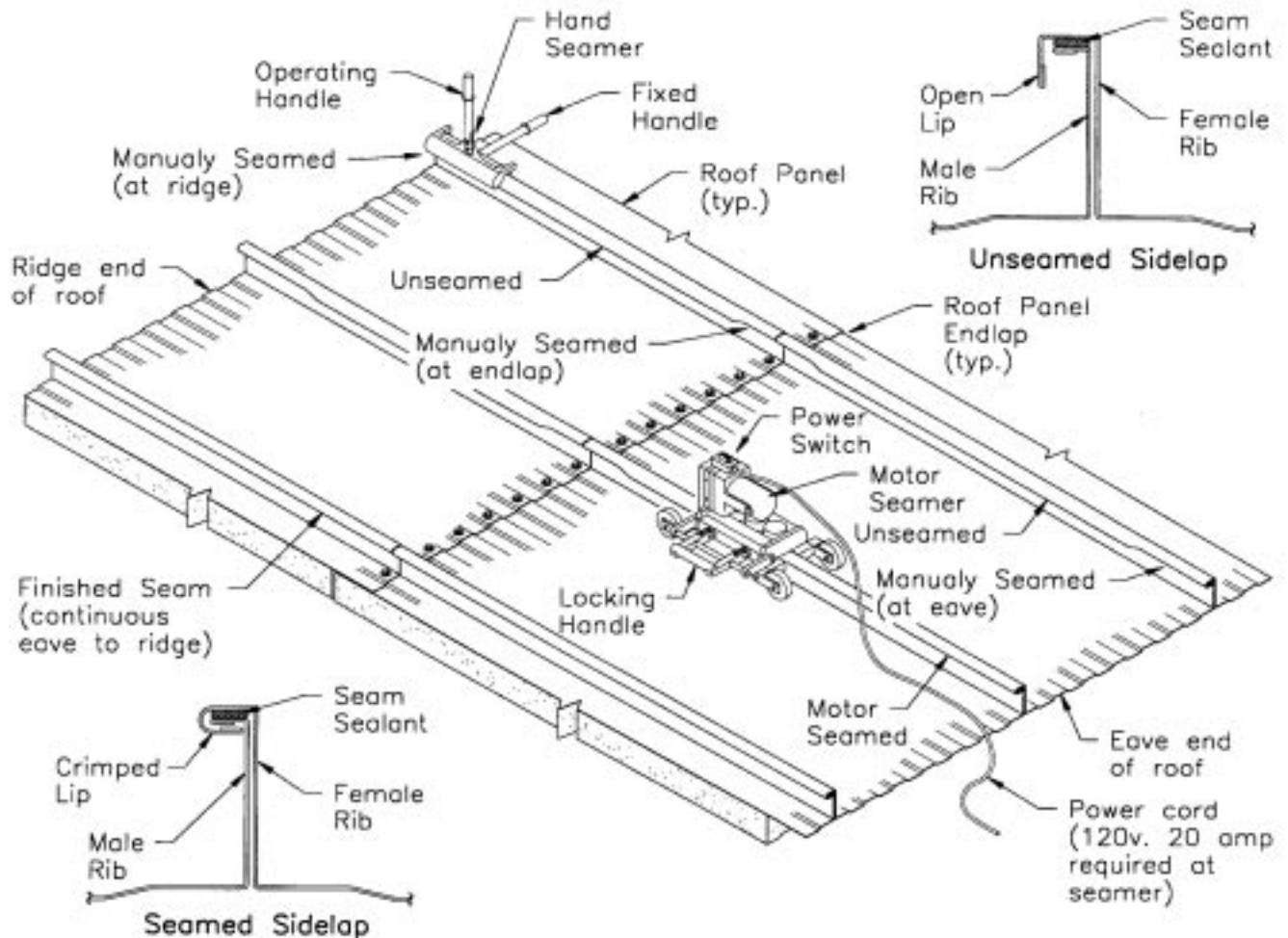

### Typical Roof Panel Seaming

1. This detail describes the seaming of the roof panel sidelaps. Because the roof system does not have its full wind and weather resistance capabilities until it is fully seamed, the sidelaps should be seamed as soon as possible after panel installation.
2. Use the manual seaming tool to seam (crimp) each roof sidelap at the eave and ridge end of the panels and at the roof panel endlaps. Seam at least 10" of sidelap in these areas.
3. To operate the manual seamer – Orient the seamer so that the operating handle is on the left side (when facing upslope). While holding the operating handle vertical and the fixed handle horizontal, place the tool fully over the sidelap. Seam the sidelap by rotating the operating handle down to horizontal.
4. To operate the motor seamer – Orient the machine so that its locking handle is on the left side (when facing upslope). While holding the locking handle up, set the machine fully over a manual seamed area. Lock the machine to the sidelap by pushing the locking handle down until it snaps locked. The machine may be run upslope or downslope. Use the machine's power switch to control the seamer's travel direction.
5. Refer to the instructions provided with the seaming machine for specific operating and maintenance instructions.





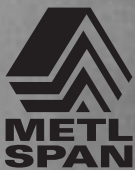

1497 NORTH KEALY  
LEWISVILLE, TEXAS 75057  
TEL : 877-585-9969  
FAX: 972-436-0648  
WEB: [www.metl-span.com](http://www.metl-span.com)  
EMAIL: [panel@metl-span.com](mailto:panel@metl-span.com)