

# Erectomatic®

Industrial Shelving



[www.pencoproducts.com](http://www.pencoproducts.com)





# About Penco

## Stack It, Store It, Secure It



The need for storage products is universal and Penco has grown a wide spectrum of solutions to fill that need. In doing so, Penco has become one of America's largest and most trusted suppliers of storage and work-area products. With state-of-the-art US manufacturing facilities and QuickShip Distribution Centers strategically located throughout the United States and Canada, Penco is positioned to best serve your needs.

Market sectors served by Penco include educational, healthcare, and government facilities, as well as offices, manufacturing companies, distribution warehouses, retail outlets, sports arenas and community parks.

Shelving and pallet rack products are popular with warehousing and manufacturing applications, ranging from a few units to multi-level and high rise applications.

Lockers are widely used in educational facilities, fitness centers, healthcare, military, emergency response, commercial and industrial locations.

Other products such as storage cabinets, work benches and shop furniture are used wherever material gets shipped, received or stored.



Erectomatic® & Hi-Performance® are registered Trademarks of Penco Products, Inc.

## Penco's 140 Year History

In 1869, a man named L. Lewis Sagendorph fulfilled his ambition to begin his own company that would produce the finest metal products in America. He called his fledgling business the Penn Metal Corporation of Pennsylvania, and began by making steel culvert pipe on Oregon Avenue in South Philadelphia.



Over the years, Penn Metal's product lines broadened to include lockers, shelving and even aircraft landing mats. A reputation for quality fabrication spread, and the company's influence became nationwide. In the 1950's, the name was shortened to

Penco Products and the plant and offices were expanded to a modern facility in Oaks, Pennsylvania, near Valley Forge, PA.

In 2001, the manufacturing facilities were moved from Oaks to a 475,000 square foot manufacturing facility in Hamilton, North Carolina, allowing significant room for expansion. The corporate headquarters remains in Pennsylvania.



Headquarters in Skippack, PA



Manufacturing facility in Hamilton, NC

## Customer Service

Penco's Customer Service staff is a customer friendly, knowledgeable team that is dedicated to excellence in service delivery and communication. The team is based at Penco's Skippack, Pennsylvania headquarters in a state-of-the-art work area.

Our goal is to provide professional, courteous, timely and accurate service to every customer in a fair, consistent and accessible manner. Penco's distributor partners and customers are our number one priority and focus.

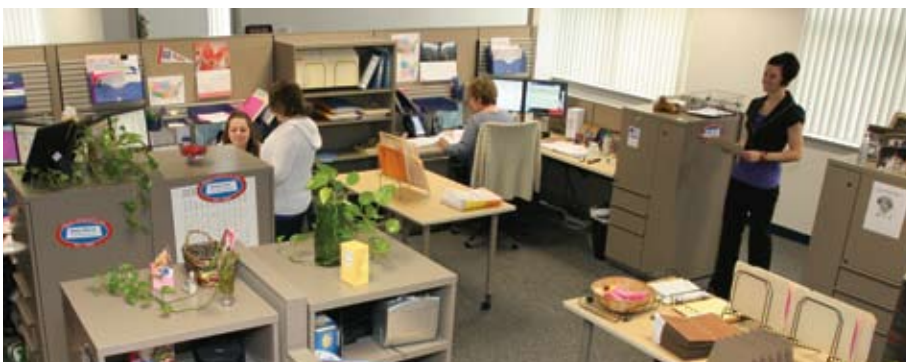



# Erectomatic® Shelving Highlights / Contents

The Erectomatic Hi-Performance Shelving System is designed for greater strength, durability and versatility. Start with a single-tiered system today and expand into high density, multi-level or high rise systems tomorrow. At the heart of the system is the Hi-Performance welded box-beam flange shelf designed to be:

- Stronger - capacities from 400 lbs to 2,000 lbs!
- Simpler - no need for shelf reinforcing channels...even for extra heavy duty capacity shelving. That means fewer parts, less expense.
- Versatile - can be used with your choice of four posts types.

Along with the box-beam shelf, the Erectomatic Hi-Performance Shelving System features Beaded Posts, Angle Posts, Welded T-Posts, Heavy Duty H-Posts and a one-piece shelf clip with a complete line of accessories that can be added as your storage requirements change.

Together, these high quality shelving components provide safe organized storage that is designed to allow for easy modifications and future expansion to meet your changing needs.

## Erectomatic Beaded Posts

Beaded front and welded together at rear flange for strength. Flush to permit straight-in/straight-out shelf installation or shelf changing. Enables full use of the shelf width for storage. No dead space behind post. Provides easy independent vertical shelf adjustment on 1-1/2" centers. For use in the front of the unit only. See page 11 for more information.



## Erectomatic Offset Angle and T-Posts

Used at the rear of the unit these posts are punched on 1-1/2" centers to allow quick, independent shelf adjustment. T-Posts consist of two angle posts welded together. They are used as common posts between units for faster assembly and fewer parts. See page 11 for more information.



## Erectomatic Heavy Duty H-Posts

All the advantages of the Flush Beaded Posts plus more than two times the load-carrying capacity. These heavy duty posts are common to front or rear and can support high rise or high density storage systems using standard Erectomatic components throughout. See page 12 for more information.



## Erectomatic One Piece Shelf Clip

A non-intrusive one piece compression clip, designed to secure the shelf to any Erectomatic post without intruding into the area to be devoted to storage. Four clips are provided with each shelf. See page 16 for more information.



## Erectomatic® Hi-Performance® Shelves

Manufactured from high strength steel, front and rear flanges are formed into a tubular box shape and welded to the underside of the shelf on 3" centers for superior strength. Shelf corners are lapped and welded and sides are double flanged. A special design feature keeps clips snug against the shelf regardless of shelf class. Available in four load capacity classes. Sizes up to 48" wide and 36" deep. Shelves are punched to accept accessories such as dividers, label holders, bin fronts and base strips. For use with all Erectomatic posts. Can be independently installed or re-positioned using four one-piece compression clips. See page 17 for more information.



## Contents

Introduction.....	2-5
Units.....	6-10
Components .....	11-13
Accessories .....	14-15
Multi-Level Components/Hardware..	15-16
Shelves .....	17
Drawers .....	18-23
Mezzanines & Multi-Level.....	24-25
Grating.....	26
Stairs & Safety Products.....	27
Specifications .....	28
Installation Photos.....	29
Colors .....	30
Other Penco Products .....	31



©2012 Penco Products, Inc., All Rights Reserved. Erectomatic®, Hi-Performance®, Clipper® and RivetRite® are Trademarks of Penco Products, Inc.



### Post Load Capacity Information

Post calculations should always be based on applied loads, shelf spacing and the allowable load for any post. To determine the actual load for any post, use the following procedure.

- Add the shelves in each unit multiplied by the load for each shelf. Do not include the bottom shelf which is 3" above the floor in your count.
- Divide the result by 2 to achieve loading to intermediate posts, and by 4 to achieve loading totals for posts located at aisle ends.
- The resulting numbers will be the load superimposed on each post.
- Check the superimposed load with the allowable load shown in the chart below.

If your shelving installation is in an area where seismic activity may occur, please contact Penco Products for design assistance.

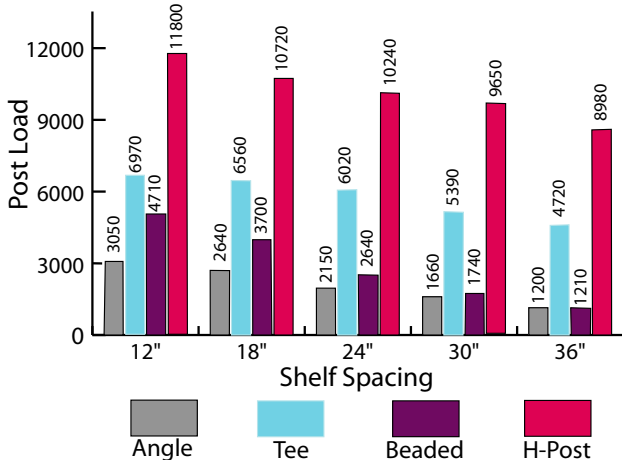

All post capacities shown are based on the latest AISI Design Manual for cold-formed members.

### Sway Braces

Open shelving units, 87' high or less, must have at least one set of side sway braces per side and one set of back braces. Both side and back braces may be common with adjacent units. For multiple level, deck-over or high-rise shelving structures, the lowest set of braces should be within 6" of the floor. For posts over 87" high up to 123", order two sets of side and rear braces for each unit. Posts taller than 123" may require additional bracing.

For brace location requirements in regions where there is seismic activity, contact Penco Products for assistance.

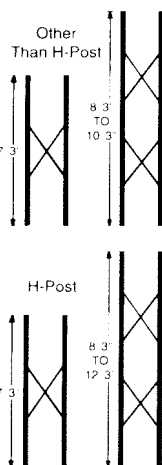

### Unit Growth

#### Beaded Post Shelving

For "D" — Single Face add 3/16" to nominal shelf depth.

For "D" — Double Face add 3/8" to nominal shelf depth.

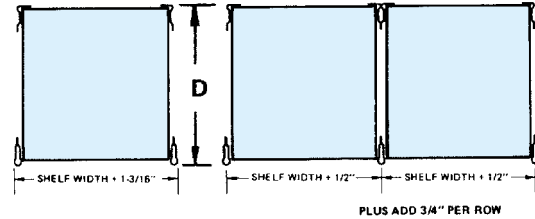

#### H-Post Shelving

For "D1" — Single Face add 5/16" to nominal shelf depth.

For "D1" — Double Face add 13/16" to nominal shelf depth for closed models, and 29/32" for open models.

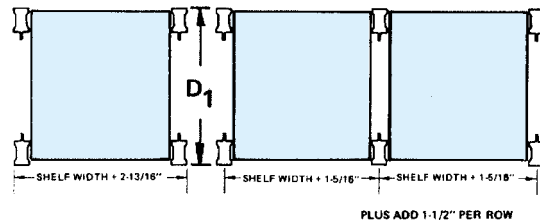

NOTE: Widths of Erectomatic posts should be added to the nominal shelf width in any floor plan to determine the overall shelving width. Check "D" and "D1" dimensions depth.

### The Most Reliable Shelf Test Method in the Industry

Test methods simulate actual applications to the highest degree possible. Evenly distributed static loads of boxed hardware are spaced to prevent "bridging" (product stacked together forms a mass like a stone archway resulting in a false safe load) to determine the maximum safe load for each size and type of shelf.

In actual usage, there is a risk that the recommended safe load may be exceeded, depending upon the type, size and placement of material on the shelf. A safety factor of 1.65 is included for your protection. Impact load, and point loads, such as standing on the shelf (unsafe) are not included in test procedures.

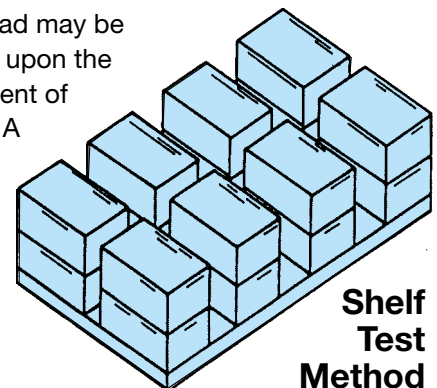

**Shelf Test Method**



**Versatile Erectomatic® Shelving can be accessorized for any job.**

**Sliding Divider**

Formed to fit around front and rear flanges of the shelf. May be positioned anywhere along shelf surface.

**Partial Divider**

Divides shelf surface into sections.

**Bin Front**

To retain small bulk parts on shelf.

**Full Height Dividers**

Used to subdivide the shelf opening into smaller units. Punched top and bottom for attachment to shelves.

**Heavy Duty Modular Drawers**

Provides secure high density storage for small parts. 100% full extension.

**Shelf Boxes**

Strong steel open topped box for storing small parts. Equipped with built-in stop.

**Welded End Panel**

One piece welded assembly of steel sheet and posts used to enclose shelving sides or as a partition between sections placed side by side.

**Base Strip**

Designed to close the space between the bottom shelf and floor to promote good housekeeping.

**Back Panel**

Completely closes the back of shelving units and provides lateral stability.

**Hi-Performance® Shelf**

Available in 19 sizes and 4 classes of load carrying capacity.

**Beaded Post**

Used as a common front post or row end. Allows independent 1-1/2" vertical adjustability and access to the full shelf width.

**Offset Angle Post**

Roll formed for strength and punched on 1-1/2" centers for shelf adjustment. Can be used at front or back of unit.

**Side Braces**

Eliminates front to back sway on open type shelving.

**Back Braces**

Attaches to rear posts of open type shelving to ensure lateral stability.

**Label Holder**

Accepts 7/8" labels.



**CLOSED Shelving Unit**

**OPEN Shelving Unit**

# Erectomatic®

## Open Shelving Units



All Units Are 87" High  
and have Heavy Duty  
Hi-Performance® Shelves

Open shelving is the most basic method of storing packaged or bulky items. Units feature Beaded Posts at the front of the unit and Offset Angle or T-Posts at the rear and are stabilized by side and back sway bracing. All starting units are complete and free standing. Open starting units utilize beaded front posts with offset angle posts at the rear. Adjoining open shelving units consist of shelves, 1 beaded post, 1 T-post, 1 set of side sway braces and 1 set of back sway braces.

When installing a row of shelving with starting and adjoining units, a rear angle post from the starting unit is replaced with the T-Post supplied with the adjoining unit, and is used in common between the units. The angle post from the starting unit is used at the end of the row.

Back-to-back shelving utilizes common back braces.

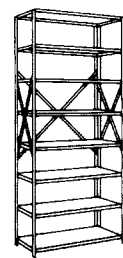
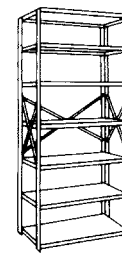
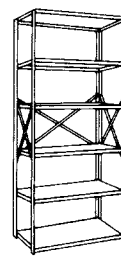
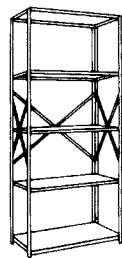
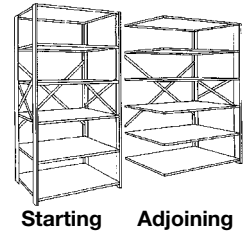

Many other sizes are available.

**5 Shelves**

**6 Shelves**

**7 Shelves**

**8 Shelves**

Width	Depth	Height	Starting	Starting	Starting	Starting
36" Wide Units	12"	87"	H51012	H51112	H51212	H51312
	18"	87"	H51018	H51118	H51218	H51318
	24"	87"	H51024	H51124	H51224	H51324
	30"	87"	H51030	H51130	H51230	H51330
	36"	87"	H51036	H51136	H51236	H51336
42" Wide Units	12"	87"	H57512	H57712	H57912	-
	18"	87"	H57518	H57718	H57918	-
	24"	87"	H57524	H57724	H57924	-
	30"	87"	H57530	H57730	H57930	-
	36"	87"	H57536	H57736	H57936	-
48" Wide Units	12"	87"	H56912	H57112	H57312	-
	18"	87"	H56918	H57118	H57318	-
	24"	87"	H56924	H57124	H57324	-
	30"	87"	H56930	H57130	H57330	-
	36"	87"	H56936	H57136	H57336	-
Width	Depth	Height	Adjoining	Adjoining	Adjoining	Adjoining
36" Wide Units	12"	87"	H51012A	H51112A	H51212A	H51312A
	18"	87"	H51018A	H51118A	H51218A	H51318A
	24"	87"	H51024A	H51124A	H51224A	H51324A
	30"	87"	H51030A	H51130A	H51230A	H51330A
	36"	87"	H51036A	H51136A	H51236A	H51336A
42" Wide Units	12"	87"	H57512A	H57712A	H57912A	-
	18"	87"	H57518A	H57718A	H57918A	-
	24"	87"	H57524A	H57724A	H57924A	-
	30"	87"	H57530A	H57730A	H57930A	-
	36"	87"	H57536A	H57736A	H57936A	-
48" Wide Units	12"	87"	H56912A	H57112A	H57312A	-
	18"	87"	H56918A	H57118A	H57318A	-
	24"	87"	H56924A	H57124A	H57324A	-
	30"	87"	H56930A	H57130A	H57330A	-
	36"	87"	H56936A	H57136A	H57336A	-



# Erectomatic®

## Closed Shelving Units



All Units Are 87" High  
and have Heavy Duty  
Hi-Performance® Shelves

Many other sizes are available.

End panels, T-panels and back panels provide stability and protection for stored items. Front base strips are included. Locking doors may be added for greater security. All starting units are complete and free standing. Closed starting units use welded end panels. Closed adjoining units consist of shelves, 1 T-Panel, 1 base strip and a back panel.

When installing a row of shelving with starting and adjoining units, an end panel from the starting unit is replaced with the T-Panel supplied with the adjoining unit, and is used in common between the units. The angle post or end panel from the starting unit is used at the end of the row.

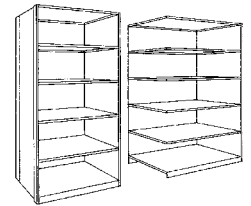

Starting Adjoining

Back-to-back shelving utilizes common back panels.

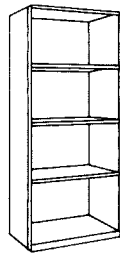

5 Shelves

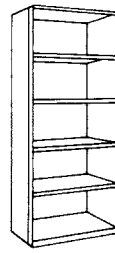

6 Shelves

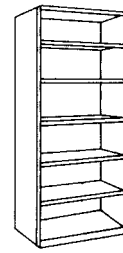

7 Shelves

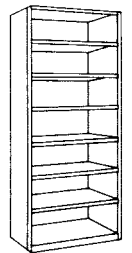

8 Shelves

Width	Depth	Height	Starting	Starting	Starting	Starting
36" Wide Units	12"	87"	H52012	H52112	H52212	H52312
	18"	87"	H52018	H52118	H52218	H52318
	24"	87"	H52024	H52124	H52224	H52324
	30"	87"	H52030	H52130	H52230	H52330
	36"	87"	H52036	H52136	H52236	H52336
42" Wide Units	12"	87"	H57612	H57812	H58012	-
	18"	87"	H57618	H57818	H58018	-
	24"	87"	H57624	H57824	H58024	-
	30"	87"	H57630	H57830	H58030	-
	36"	87"	H57636	H57836	H58036	-
48" Wide Units	12"	87"	H57012	H57212	H57412	-
	18"	87"	H57018	H57218	H57418	-
	24"	87"	H57024	H57224	H57424	-
	30"	87"	H57030	H57230	H57430	-
	36"	87"	H57036	H57236	H57436	-
Width	Depth	Height	Adjoining	Adjoining	Adjoining	Adjoining
36" Wide Units	12"	87"	H52012A	H52112A	H52212A	H52312A
	18"	87"	H52018A	H52118A	H52218A	H52318A
	24"	87"	H52024A	H52124A	H52224A	H52324A
	30"	87"	H52030A	H52130A	H52230A	H52330A
	36"	87"	H52036A	H52136A	H52236A	H52336A
42" Wide Units	12"	87"	H57612A	H57812A	H58012A	-
	18"	87"	H57618A	H57818A	H58018A	-
	24"	87"	H57624A	H57824A	H58024A	-
	30"	87"	H57630A	H57830A	H58030A	-
	36"	87"	H57636A	H57836A	H58036A	-
48" Wide Units	12"	87"	H57012A	H57212A	H57412A	-
	18"	87"	H57018A	H57218A	H57418A	-
	24"	87"	H57024A	H57224A	H57424A	-
	30"	87"	H57030A	H57230A	H57430A	-
	36"	87"	H57036A	H57236A	H57436A	-

# Erectomatic®

## 36" Wide Bin Units

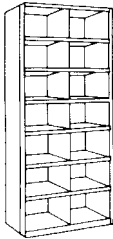
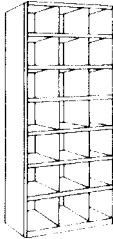
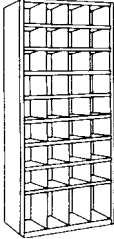
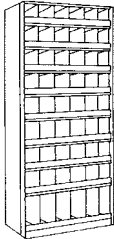
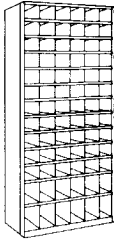
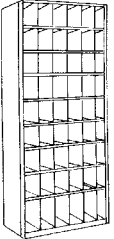

**Erectomatic Bin Units** are for storage of smaller parts and packaged goods. Easy access to materials stored. Save time in locating and picking stock. **Models are 36" wide, 87" high in depths shown, and use Heavy Duty Hi-Performance® Shelves.** Enclosed back and sides. Base Strips included. Bin openings are width x height. Many other sizes are available.

												
	Openings	Size	Openings	Size	Openings	Size	Openings	Size	Openings	Size	Openings	Size
	14	18" x 12"	21	12" x 12"	32 4	9" x 9" 9" x 12"	48 6	6" x 9" 6" x 12"	66 12	6" x 6" 6" x 9"	48 6	6" x 9" 6" x 12"
	All with 3" High Bin Fronts											
Shelf Depth	Starting		Starting		Starting		Starting		Starting		Starting	
12"	H52512		H52612		H52712		H52812		H52912		H53012	
18"	H52518		H52618		H52718		H52818		H52918		H53018	
24"	H52524		H52624		H52724		H52824		H52924		H53024	
Shelf Depth	Adjoining		Adjoining		Adjoining		Adjoining		Adjoining		Adjoining	
12"	H52512A		H52612A		H52712A		H52812A		H52912A		H53012A	
18"	H52518A		H52618A		H52718A		H52818A		H52918A		H53018A	
24"	H52524A		H52624A		H52724A		H52824A		H52924A		H53024A	

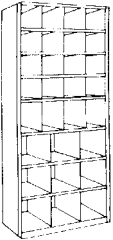
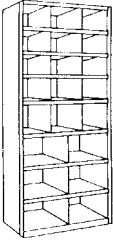
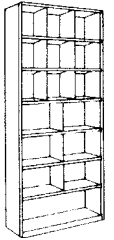
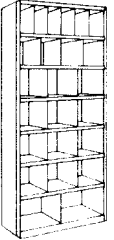
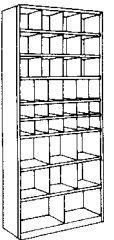
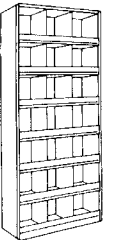
												
	Openings	Size	Openings	Size	Openings	Size	Openings	Size	Openings	Size	Openings	Size
	16 4 9	9" x 9" 9" x 12" 12" x 12"	12 3 6	12" x 9" 12" x 12" 18" x 12"	9 6 1	12" x 12" 18" x 12" 36" x 12"	6 4 12 2	6" x 12" 9" x 12" 12" x 12" 18" x 12"	12 6 12 6 2	9" x 9" 6" x 9" 6" x 6" 12" x 12" 18" x 12"	21	12" x 12"
	With 3" High Bin Fronts											
Shelf Depth	Starting		Starting		Starting		Starting		Starting		Starting	
12"	H53112		H53212		H53312		H53412		H53512		H53612	
18"	H53118		H53218		H53318		H53418		H53518		H53618	
24"	H53124		H53224		H53324		H53424		H53524		H53624	
Shelf Depth	Adjoining		Adjoining		Adjoining		Adjoining		Adjoining		Adjoining	
12"	H53112A		H53212A		H53312A		H53412A		H53512A		H53612A	
18"	H53118A		H53218A		H53318A		H53418A		H53518A		H53618A	
24"	H53124A		H53224A		H53324A		H53424A		H53524A		H53624A	





# Erectomatic®

## Shelf Box and Ledge Units

**Erectomatic Shelf Box Units** are ideal for storing for drills, reamers, fasteners, and small parts. Drawers can be easily removed and taken to the work station. **All models are 36" wide and 87" high**, and use Heavy Duty Hi-Performance® Shelves. Bin openings are width x height. Base strip included. Many other sizes are available.

	Openings	Size	Openings	Size	Openings	Size	Openings	Size	Openings	Size	Openings	Size
	8	9" x 9"	3	12" x 6"								
	9	12" x 12"	12	6" x 6"								
	6	6" x 6"	3	12" x 12"	36	6" x 6"	-	-	-	-	-	-
	2	18" x 12"	2	18" x 6"								
			2	18" x 12"								
	12 Shelf Boxes, 5-5/8" wide with 2 dividers ea.		4 shelves w/12 partial dividers each. 12 Shelf Boxes 5-5/8" wide with 2 dividers ea.		48 Shelf Boxes 5-5/8" wide with 2 dividers each.		84 Shelf Boxes 5-5/8" wide with 2 dividers each.		56 Shelf Boxes 8-7/16" wide with 2 dividers ea.		Shelf Boxes with 2 dividers each: 42 5-5/8" wide 16 8-7/16" wide 9 11-1/4" wide	
<b>Shelf Depth</b>	<b>Starting</b>		<b>Starting</b>		<b>Starting</b>		<b>Starting</b>		<b>Starting</b>		<b>Starting</b>	
12"	H53812		H53912		H54012		H54112		H54212		H54312	
18"	H53818		H53918		H54018		H54118		H54218		H54318	
24"	H53824		H53924		H54024		H54124		H54224		H54324	
<b>Shelf Depth</b>	<b>Adjoining</b>		<b>Adjoining</b>		<b>Adjoining</b>		<b>Adjoining</b>		<b>Adjoining</b>		<b>Adjoining</b>	
12"	H53812A		H53912A		H54012A		H54112A		H54212A		H54312A	
18"	H53818A		H53918A		H54018A		H54118A		H54218A		H54318A	
24"	H53824A		H53924A		H54024A		H54124A		H54224A		H54324A	

**Erectomatic Ledge Units** combine storage space with a work surface. Models are **36" wide and 87" high**, and use Heavy Duty Shelves, in the depths shown. Closed units include front base strips. Accessorize to fit your requirement with dividers, label holders, doors, etc. selected from the component parts pages of this catalog.

	Description	Description	Openings	Size
	4 adjustable shelves above ledge, 3 below	4 adjustable shelves above ledge, 3 below	12	12" x 9"
			1	36" x 12"
			2 adj. shelves with 3" high bin fronts below ledge	
<b>Shelf Depth Above</b>	<b>Starting</b>	<b>Starting</b>	<b>Starting</b>	
12"	H5491218	H5501218	H5511218	
12"	H5491224	H5501224	H5511224	
18"	H5491824	H5501824	H5511824	
<b>Shelf Depth</b>	<b>Adjoining</b>	<b>Adjoining</b>	<b>Adjoining</b>	
12"	H5491218A	H5501218A	H5511218A	
12"	H5491224A	H5501224A	H5511224A	
18"	H5491824A	H5501824A	H5511824A	

# Erectomatic®



## Counter Units & Cabinet Models

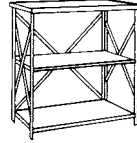
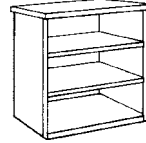
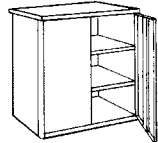

All Erectomatic Counter Units are 36" wide and 39" high. They provide neat compact storage with a smooth work surface. Shelves are Heavy Duty. Base Strip included with closed models. Counter models accept standard shelving accessories. See component pages of this catalog.

			
	Description	Description	Description
	2 adjustable shelves	2 adjustable shelves	2 adjustable shelves 2 swinging doors
Shelf Depth	Starting	Starting	Starting
18"	H55418	H55518	H55818
24"	H55424	H55524	H55824
Shelf Depth	Adjoining	Adjoining	Adjoining
18"	H55418A	H55518A	H55818A
24"	H55424A	H55524A	H55824A

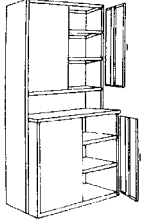
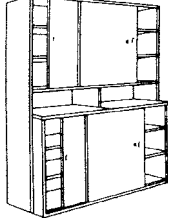
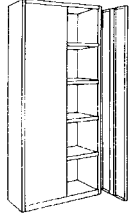
**Erectomatic Cabinet Models** are completely enclosed with swinging or sliding doors. Doors are equipped with locks to provide security. Swinging doors have a 3-point latching, chrome finished handles, and built-in lock. Sliding doors have cylinder lock; glide on nylon rollers and guides. **Models are 87" high**, in the widths and shelf depths shown with Heavy Duty Shelves. Base Strips included.

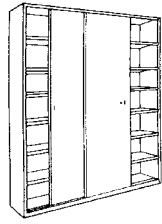
									
		Description	Description				Description	Description	Description
		36" Wide	72" Wide				36" Wide	36" Wide	72" Wide
		2 adjustable shelves above ledge 2 adjustable shelves below ledge 2 sets swinging doors	4 adjustable shelves above ledge 4 adjustable shelves below ledge 2 sets sliding doors				4 adjustable shelves 2 swinging doors	5 adjustable shelves 2 sets of swinging doors	12 adjustable shelves 1 set of sliding doors
Shelf Depth Above	Shelf Depth Below	Starting	Starting	Shelf Depth	Starting	Starting	Starting	Starting	
12"	18"	H5641218	H5651218	12"	H55912	H56312	-	-	
12"	24"	H5641224	H5651224	18"	H55918	H56318	H56618	H56618	
18"	24"	H5641824	H5651824	24"	H55924	H56324	H56624	H56624	
Shelf Depth	Shelf Depth	Adjoining	Adjoining		Adjoining	Adjoining	Adjoining	Adjoining	
12"	18"	H5641218A	H5651218A	12"	H55912A	H56312A	-	-	
12"	24"	H5641224A	H5651224A	18"	H55918A	H56318A	H56618A	H56618A	
18"	24"	H5641824A	H5651824A	24"	H55924A	H56324A	H56624A	H56624A	



# Erectomatic® Shelving Components

Erectomatic Shelving Components can be ordered in any combination for all kinds of custom applications. Be certain to order shelves and posts of sufficient capacity to hold the maximum expected load (refer to the capacity information on pages 4 and 17).

Posts and panels are available in custom heights (minimum quantity may apply). Contact your representative with your requirements.

Dimensions (inches)  
Width Depth Height Cat. No.

## Beaded Front Post

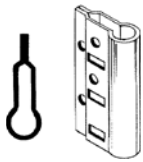

Used at front of shelving, in single units or in common with adjoining unit. Permits full access to shelf width. Allows independent adjustment of shelves on 1-1/2" centers.

Width	Depth	Height	Cat. No.
-	-	39	H0023C
-	-	75	H0026C
-	-	87	H0027C
-	-	99	H0028C
-	-	123	H00210C

## Offset Angle Post

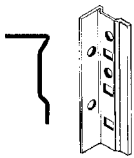

Angles for rear of single or end units. Slotted on 1-1/2" centers to permit easy shelf adjustment.

Width	Depth	Height	Cat. No.
-	-	39	H0043C
-	-	75	H0046C
-	-	87	H0047C
-	-	99	H0048C
-	-	123	H00410C

## T-Post

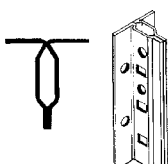

Constructed by spotwelding two offset angle posts together. Use at rear of shelving when adjoining units are added to form a continuous row.

Width	Depth	Height	Cat. No.
-	-	39	H0063C
-	-	75	H0066C
-	-	87	H0067C
-	-	99	H0068C
-	-	123	H00610C

## Foot Plate, Erectomatic Post (zinc plated)

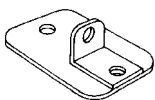

1/8" thick with mounting bracket for bolting to post. Has 7/16" diameter hole for floor anchor bolts. Includes hardware to fasten to post. If shims are required, use shim No. H026 (page 12).

Width	Depth	Height	Cat. No.
2-1/4	3-1/2	-	H050H

Dimensions (inches)  
Width Depth Height Cat. No.

## Heavy Duty Footplate for Beaded, Angle and Tee Posts—7 ga.

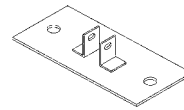

Includes two mounting brackets and intended for use in high seismic areas or in conditions where post loading is intended to be spread over a larger area, such as on a mezzanine/work platform elevated deck. Footplate is drilled to accept 3/8" floor anchors, and can be used with 9281 3/8"x 3-3/4" wedge anchors to meet IBC 2003/2006 building code requirements in high seismic areas.

Width	Depth	Height	Cat. No.
2-3/8	5-1/2	-	1ACX326H

## Heavy Duty Shim - 7 Ga.

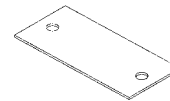

Fits under 1ACX326H footplate for leveling as needed.

Width	Depth	Height	Cat. No.
2-3/8	5-1/2	-	1ACX330

## Concrete Floor Anchor



Use the longer anchor # 9281 in seismic zones higher than 2A.

Width	Depth	Height	Cat. No.
3/8	-	2-1/4	9280
3/8	-	3-3/4	9281

## Splice Channels, For Beaded, Angle and T-Post

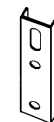

Used when splicing posts. Splice and aisle supports use common hardware. Replaces Part No. H009H

Width	Depth	Height	Cat. No.
-	-	-	HXAS071H

## End Panel, (welded 1 piece)

Welded one-piece construction for easy assembly. Consists of beaded front post, offset angle post and one-piece side panel welded together on 6" centers. For left or right ends of single units or row ends.

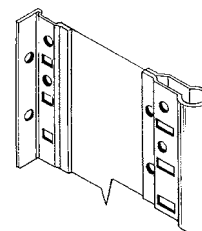

Width	Depth	Height	Cat. No.
-	12	39	H0921203C
-	12	75	H0921206C
-	12	87	H0921207C
-	12	99	H0921208C
-	12	123	H0921210C
-	15	87	H0921507C
-	18	39	H0921803C
-	18	75	H0921806C
-	18	87	H0921807C
-	18	99	H0921808C
-	18	123	H0921810C
-	24	39	H0922403C
-	24	75	H0922406C
-	24	87	H0922407C
-	24	99	H0922408C
-	24	123	H0922410C
-	30	87	H0923007C
-	36	87	H0923607C



Dimensions (inches)  
Width Depth Height Cat. No.

## T-Panel

Welded construction for easy assembly. Consisting of beaded front post, T-post and one-piece side panel welded on 6" centers. For use between units when adjoining models are added to form a continuous shelving row.

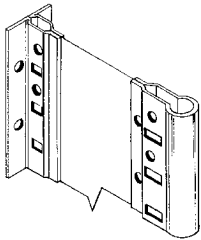

Width	Depth	Height	Cat. No.
-	12	39	H0941203C
-	12	75	H0941206C
-	12	87	H0941207C
-	12	99	H0941208C
-	12	123	H0941210C
-	15	87	H0941507C
-	18	39	H0941803C
-	18	75	H0941806C
-	18	87	H0941807C
-	18	99	H0941808C
-	18	123	H0941810C
-	24	39	H0942403C
-	24	75	H0942406C
-	24	87	H0942407C
-	24	99	H0942408C
-	24	123	H0942410C
-	30	87	H0943007C
-	36	87	H0943607C

## Ledge Panel

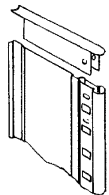

For converting open or closed type shelving models to ledge models. All-welded construction. Combines beaded front post and preformed panel into a one-piece unit. Ledge panel cover is included.

Width	Depth	Height	Cat. No.
-	6	39	H0120306H
-	12	39	H0120312H
-	18	39	H0120318H

## Back Panel

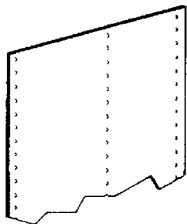

Punched on 1" centers at vertical edges and center for mounting to back of posts and shelves. 36" wide backs are furnished in 1 piece through 87" high; above 87" they are split horizontally. 42" & 48" wide backs are furnished in 1 piece through 51" high; above 51" they are split horizontally. Includes back clip and hardware.

Width	Depth	Height	Cat. No.
36	-	39	12500H
36	-	51	12510H
36	-	75	12530H
36	-	87	12540H
36	-	99	12550H
42	-	39	12600H
42	-	51	12610H
42	-	87	12640H
42	-	99	12650H
48	-	39	12700H
48	-	51	12710H
48	-	87	12740H
48	-	99	12750H

Dimensions (inches)  
Width Depth Height Cat. No.

## Side Sway Braces, For Beaded Post Unit, (Pair)

One pair forms a set which bolts to the front and rear posts for stability. Can be used in common between adjoining units. NOT for use with H-Posts.

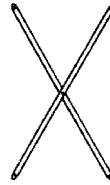

Width	Depth	Height	Cat. No.
-	12	-	12015S
-	15	-	12019S
-	18	-	12026S
-	24	-	12034S
-	30	-	12045S
-	36	-	12049S

## Back Sway Braces, For Back, T, & H-Post, (Pair)

Each pair forms a set which bolts to posts at rear of unit for stability. Can be used in common with back to back units.

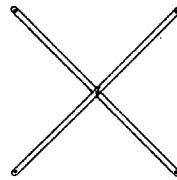

Width	Depth	Height	Cat. No.
36	-	-	12036H
42	-	-	12042H
48	-	-	12048H

## H-Post

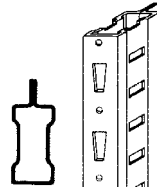

Very strong tubular design. 1-1/2" wide x 2-15/16" deep in heights shown. Used in front and rear post positions. Sides slotted on 1-1/2" centers for shelf clip adjustment. Has more load carrying capacity than beaded or angle posts.

Width	Depth	Height	Cat. No.
-	-	87	H0037C
-	-	99	H0038C
-	-	123	H00310C
-	-	147	H00312C

## Foot Plate, H-Post, Light/Medium Duty

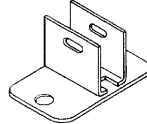

Mounting bracket welded to top for bolting inside H-Posts. Base plate has 7/16" diameter hole for floor anchor bolts.

Width	Depth	Height	Cat. No.
3-1/2	2-1/4	-	H025H

## Foot Plate, H-Post, Heavy Duty

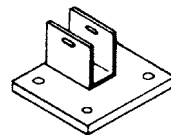

Mounting bracket is welded to top for bolting inside H-Post. Base plate is 3/8" thick and has four 7/16" diameter holes for receiving the embosses in shim plate (No. H016) and for floor anchor bolt.

Width	Depth	Height	Cat. No.
4	3-1/2	-	H015H

## Shim Plate, For Foot Plate, Light/Medium Duty



Fits under foot plate (Cat. No. H025H or H050H) for leveling. Has (1) 7/16" diameter hole which aligns with hole in foot plate to permit anchoring to floor.

Width	Depth	Height	Cat. No.
3-1/2	2-1/4	-	H026



# Erectomatic® Shelving Components

Dimensions (inches)  
Width Depth Height Cat. No.

## Shim Plate, H-Post, Heavy Duty

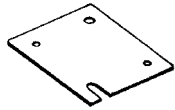

Fits under foot plate (Cat. No. H015H) for leveling. Has (2) 7/16" diameter holes which align with footplate holes to permit anchoring to floor.

4	3-1/2	-	H016
---	-------	---	------

## Side Panel, H-Post

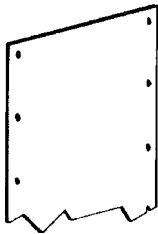

Provides closed side panels sections where desired. Punched on 6" centers for mounting to front and rear H-Posts. Attach 1/4 x 20 pan head screws (included).

-	18	39	H0911803H
-	18	87	H0911807H
-	24	39	H0912403H
-	24	87	H0912407H
-	36	39	H0913603H
-	36	87	H0913607H

## Connector Strip, For H-Post Back

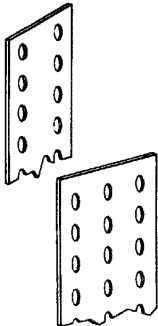

For connecting Back Panels or braces to rear H-Posts; punched on 1" centers. 2-1/16" wide pieces are for back posts at row ends. 3-1/8" wide pieces are for adjoining intermediate back posts, and are punched at outside vertical edges & center. Hardware included.

2-1/16	-	39	H1143H
2-1/16	-	51	H1144H
2-1/16	-	87	H1147H
3-1/8	-	39	H1153H
3-1/8	-	51	H1154H
3-1/8	-	87	H1157H

## Side Sway Braces, H-Post, (Pair)

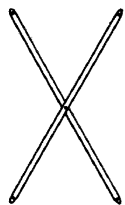

Each pair forms a set for connecting front and rear H-Posts for stability. Can be used in common with adjoining unit (for H-Posts ONLY).

-	12	-	H34112H
-	15	-	H34115H
-	18	-	H34118H
-	24	-	H34124H
-	30	-	H34130H
-	36	-	H34136H

## Splice, H-Post



For use in multi-level and high rise shelving. Fits inside two connecting H-Posts. Punched for bolting. Maintains post strength at the splice without interfering with clips or other accessories. Hardware included.

-	-	9-3/4	H010H
---	---	-------	-------

Dimensions (inches)  
Width Depth Height Cat. No.

## Combination Clip, H-Post, (zinc plated)

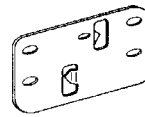

Mounts to rear H-Posts to provide anchor point for back sway braces. Also used to connect H-Posts and common back panels or common back sway braces together in back to back models. Hardware included. Not for use in high seismic areas.

-	-	-	H027H
---	---	---	-------

## Support Brace for Bottom Shelf (For Class 3 Only)

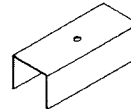

Used only on Class 3 bottom shelves to support center support hat section. Positioned in center of shelf; rests on floor. Includes hardware.

5-1/8	2-1/16	1-3/4	H131H
-------	--------	-------	-------

## H-Post Beams

Beams with H-Post end connectors for use with plywood decking. Support Angle(s) are required (see below).

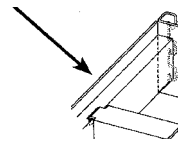

36-1/2	-	-	900036
42-1/2	-	-	900042
48-1/2	-	-	900048
72-1/2	-	-	900072
84-1/2	-	-	900084
96-1/2	-	-	900096

## Plywood Support Angles

For H-Post Beams

Use 1 for 36" & 42" 2 for 48", 3 for 72" & 84", 4 for 96" Beams.

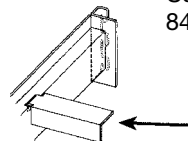

-	18	-	20349C
-	24	-	20341C
-	30	-	20330C
-	36	-	20342C
-	42	-	20332C
-	48	-	20336C

Standard H-Post Beam Capacities (With Support Angles)	36-1/2 42-1/2 48-1/2 72-1/2 84-1/2 96-1/2	2500/Pr. 2500/Pr. 2500/Pr. 1760/Pr. 1500/Pr. 1350/Pr.
All Capacities are based on uniformly distributed loads in pounds.		

## Counter Top

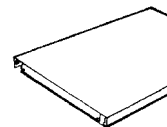

Heavy duty steel working surface with cornice at front and rear. Use End Caps for finishing cornice on ends. Hardware included.

36	18	-	H1953618H
36	24	-	H1953624H

## End Caps for Counter Top, (Pair)

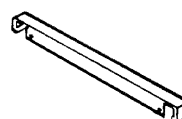

Provides a finished cornice on extreme ends of counter top applications. Sold in pairs; hardware included.

-	18	-	H20118H
-	24	-	H20124H



Dimensions (inches)  
Width Depth Height Cat. No.

### Base Strip



Shaped to fasten directly to the bottom shelf front to close the gap beneath it and the floor. Normally used with closed shelving. Includes hardware. Note: 4-1/2" high model is for use with H-Posts attached to footplates and in x-ray storage units.

36	-	3	14520H
36	-	4-1/2	H23336H
42	-	3	14530H
48	-	3	14540H

### Label Holder

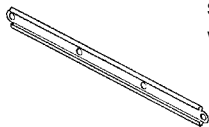

Punched for attaching to front flange of shelves. Accepts 7/8" high labels. Attaches with plastic button fasteners (included).

36	-	-	13920H
42	-	-	13930H
48	-	-	13940H

### Bin Front

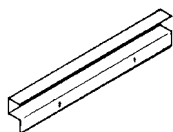

Offset type double formed at top and triple flanged at bottom to telescope over shelf flange. Hardware included.

36	-	1	14210H
36	-	2	14220H
36	-	3	14240H
42	-	3	14340H
48	-	3	14440H

### Full Divider

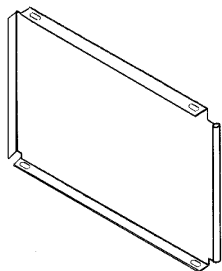

Front edge beaded; top, bottom and rear edges are flanged. Attaches with plastic button fasteners (included). For Class 3 shelving applications, contact your representative regarding special notching. Note: 16-1/2" high model is for x-ray unit.

-	12	6	15600H
-	12	9	15620H
-	12	12	15640H
-	12	18	15670H
-	15	6	15700H
-	15	12	15740H
-	18	6	15800H
-	18	9	15820H
-	18	12	15840H
-	18	16-1/2	15865H
-	18	18	15870H
-	18	24	15890H
-	24	6	15900H
-	24	9	15920H
-	24	12	15940H
-	24	18	15970H
-	24	24	15990H
-	36	18	16170H

Dimensions (inches)  
Width Depth Height Cat. No.

### Partial Divider

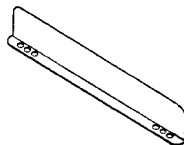

Partitions shelves from front to rear. Flanged and punched for shelf attachment. Has rounded top corners for safety. Attaches with plastic button fasteners (included).

-	12	2	16395H
-	12	4	16410H
-	18	2	16397H
-	18	4	16430H
-	24	4	16440H

### Sliding Divider, For Box Formed Shelf

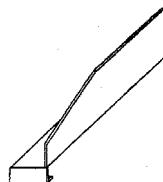

Formed to fit around front and over rear edges of shelf. Can be positioned horizontally anywhere along shelf surface. No hardware required.

-	12	4	1H4124C
-	12	6	1H4126C
-	18	4	1H4184C
-	18	6	1H4186C
-	24	4	1H4244C
-	24	6	1H4246C

### Swinging Doors, With Lock & 2 Keys

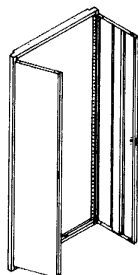

Pre-hung at the factory on a welded frame for easy assembly. Includes 3-point latch system with locking handle and 2 keys. Can be used on standard ledge or counter units up to 87" high. Six Universal Clips required for attaching doors to shelving posts. Order separately.

36	-	36	H3003636
36	-	48	H3003648
36	-	85	H3003684
48	-	36	H3004836
48	-	85	H3004884

### Sliding Doors, With Lock & 2 Keys

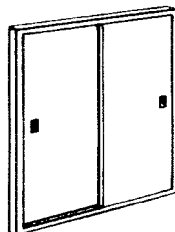

Flanged on all 4 sides and reinforced. Doors slide on quiet, smooth-running nylon rollers and guides. Complete with grooved key cylinder lock w/keys, mounting channels & universal clips. Designed for use on side by side models with shelf at top. 12 Universal Clips required for attaching to doors to shelving posts. Order separately.

72	-	36	H2907236
72	-	84	H2907284



Dimensions (inches)  
Width Depth Height Cat. No.

### Shelf Boxes

Box front has integral full finger grip and embossed label holder. Slotted on 1" centers for positioning of dividers. Dividers not included. Built-in back stop minimizes accidental removal of drawer. Available in 028 Gray only, order box dividers separately.

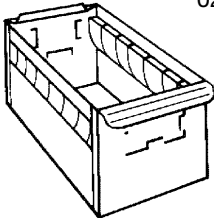

5-5/8	11	4-5/8	38030C
8-7/16	11	4-5/8	38035C
11-1/4	11	4-5/8	38040C
5-5/8	17	4-5/8	38180C
8-7/16	17	4-5/8	38185C
11-1/4	17	4-5/8	38190C
5-5/8	23	4-5/8	38255C
8-7/16	23	4-5/8	38260C
11-1/4	23	4-5/8	38265C

### Divider, Shelf Box

For quick and easy partitioning of shelf boxes on 1" centers. Galvanized steel.

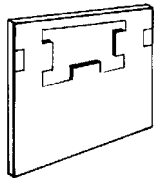

5-5/8	-	4-1/2	38306
8-7/16	-	4-1/2	38307
11-1/4	-	4-1/2	38308

### Reference Shelf - **NEW!**

A 12" deep sliding pull-out shelf designed to aid shelving users who need a work surface while working in the shelving area. Fastens beneath any Hi-Performance shelf size shown below, and neatly slides out of the way when not needed.

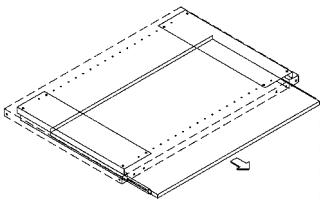

36	12	10RS03612H
36	15	10RS03615H
36	18	10RS03618H
42	12	10RS04212H
42	15	10RS04215H
42	18	10RS04218H
42	30	10RS04230H
42	32	10RS04232H
48	12	10RS04812H
48	15	10RS04815H
48	18	10RS04818H

Dimensions (inches)  
Width Depth Height Cat. No.

### Multi-Level Shelving Parts

#### Aisle Support for Use with H-Posts

For use with H-Post shelving posts and HXAS006H Aisle Support Adaptor. Provides low profile aisle supports for use with elevated shelving walkways. Can also be used to support deck-over applications.

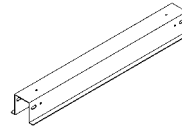

36	1-3/4	HXAS082H
48	1-3/4	HXAS177H

#### Aisle Support Adapter

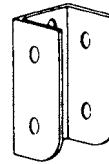

Attaches to front of H-Post with two #14 x 5/8 self-tapping screws and used to attach special aisle supports or other accessories.

-	-	HXAS006H
---	---	----------

#### End of Aisle Kickplate

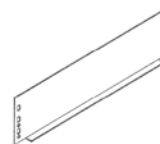

30	-	4	H2KP30
36	-	4	H2KP36
42	-	4	H2KP42
48	-	4	H2KP48

#### Grating Support Hanger

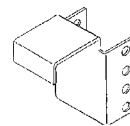

3	2	4	H2GS02
---	---	---	--------

#### Grating Support Angle

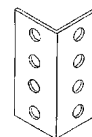

For Beaded or H Posts			
1	2	4	H2GS01

#### Multi Level Bracket

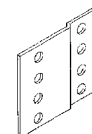

For Beaded or H Posts			
-	-	-	H2GS0



Dimensions (inches)  
Width Depth Height Cat. No.

### Multi-Level Shelving Parts, continued

*For Beaded Posts Only*

#### Cross Aisle Support

Includes hardware for Beaded Posts Only

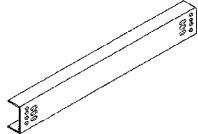
	30	-	4	H1CA30E
	36	-	4	H1CA36E
	42	-	4	H1CA42E
	48	-	4	H1CA48E

#### Grating Support Channel

Includes hardware for Beaded Posts Only

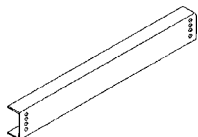
	30	-	4	H2GS30E
	36	-	4	H2GS36E
	42	-	4	H2GS42E
	48	-	4	H2GS48E

*For H Posts Only*

#### Cross Aisle Support

Includes hardware for H Posts Only

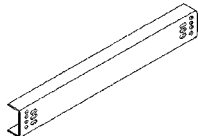
	30	-	4	H1CA30H
	36	-	4	H1CA36H
	42	-	4	H1CA42H
	48	-	4	H1CA48H

#### Grating Support Channel

Includes hardware for H Posts Only

	30	-	4	H2GS30H
	36	-	4	H2GS36H
	42	-	4	H2GS42H
	48	-	4	H2GS48H

### Touchup Paint

#### Spray Paint, 4.5 Oz. Can

049 Gray	96049 *	715 Lake Blue	97715
059 Beige	96059 *	720 Mandarin Orange	97720
012 Tawny Tan	97012	722 Patriot Red	97722
021 Gray Ash	97021	723 Light Putty	97723
028 Gray	97028	736 Burgundy	97736
052 Reflex Blue	97052	767 Cardinal Red	97767
054 Canvas	97054	806 Marine Blue	97806
055 Shamrock	97055	812 Hunter Green	97812
056 Sunburst	97056	822 Regal Blue	97822
058 Nordic Purple	97058	826 Slate Blue	97826
073 Champagne	97073	848 January White	97848
701 Spray Green	97701	949 Jet Black	97949
710 Sage Brush Yellow	97710	952 Turquoise Teal	97952

\* Historic colors to match old installations.

Dimensions (inches)  
Width Depth Height Cat. No.

### Miscellaneous Replacement Parts & Hardware

#### Shelf Clip, For Erectomatic Posts

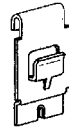

One piece compression clip that is shipped in sets of 4 with each shelf ordered. Order by single pieces for replacement use only.

- - - H133Z

#### Clip, Back Panel, (plated)

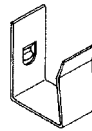

Formed to fit the bottom flange of shelf and tabbed to insert in holes in center of back panel. Holds back panel to shelf and prevents panel from bowing. Normally shipped with backs; order here for replacement use only.

- - - H120C

#### Universal Clip, To Mount Doors



Six clips required to mount swinging doors. Twelve clips required for sliding doors. Not included with doors. Order separately.

- - - H315H

#### Plastic Button



For attaching various shelving accessories such as dividers and label holders. Normally included with shipment; order here for replacement only.

- - - 8401

#### Pan Head Screws (sold in quantity of 100)

1/4-20 x 1/2	8412H
1/4-20 x 3/4	8410H
1/4-20 x 1/4	8409H
1/4-20 x 1/2 (Grade 5)	8412G5H

#### 1/4-20 Hex Nut (sold in quantity of 100)

- - -	8473H
Grade 5 - - -	8473G5H

#### Square Washer (sold in quantity of 100)

- - - 8408H





# Erectomatic® Hi-Performance® Shelves

Erectomatic® Hi-Performance® Shelves maximize load handling capacity through a design which shapes the front and rear flanges into rigid tubular box beams. The box shape provides two vertical surfaces in each box-flange that inherently give it a high strength-to-weight ratio. Additional reinforcing bars or angles are not used with Hi-Performance shelves.

The shelves are efficiently manufactured from high strength cold rolled steel on a modern automated roll forming mill.

For additional strength, front and rear flanges are welded to the underside of the shelf on 3" centers. Shelf corners are lapped and welded.

Shelves are available in a wide variety of sizes shown below in the capacity chart. All shelves are punched on 1.5" centers to accept shelving accessories such as dividers, label holders and bin fronts.

## Erectomatic® Hi-Performance® Shelves and Capacities

		Class 0 Medium Duty High Strength Steel		Class 1 Heavy Duty High Strength Steel		Class 2 Extra Heavy Duty High Strength Steel		Class 3 Extra Heavy Duty With Reinforcing*	
Unit Width	Unit Depth	Cat. No.	Capacity	Cat. No.	Capacity	Cat. No.	Capacity	Capacity	
36"	12"	H1223612C	500 lb	H1203612C	800 lb	H1183612C	1100 lb	-	
	15"	H1223615C	500 lb	H1203615C	800 lb	H1183615C	1100 lb	-	
	18"	H1223618C	500 lb	H1203618C	850 lb	H1183618C	1200 lb	2000 lb	
	24"	H1223624C	500 lb	H1203624C	800 lb	H1183624C	1250 lb	2000 lb	
	30"	-	-	H1203630C	500 lb	H1183630C	900 lb	2000 lb	
	36"	-	-	H1203636C	500 lb	H1183636C	900 lb	2000 lb	
42"	12"	-	-	H1204212C	600 lb	H1184212C	1100 lb	-	
	15"	-	-	H1204215C	600 lb	H1184215C	1100 lb	-	
	18"	-	-	H1204218C	600 lb	H1184218C	1050 lb	1600 lb	
	24"	-	-	H1204224C	600 lb	H1184224C	900 lb	1600 lb	
	30"	-	-	H1204230C	625 lb	H1184230C	1000 lb	1600 lb	
	32"	-	-	H1204232C	525 lb	H1184232C	950 lb	1600 lb	
	36"	-	-	H1204236C	475 lb	H1184236C	900 lb	1600 lb	
48"	12"	H1224812C	350 lb	H1204812C	500 lb	H1184812C	750 lb	-	
	15"	-	-	H1204815C	500 lb	H1184815C	850 lb	-	
	18"	H1224818C	375 lb	H1204818C	500 lb	H1184818C	900 lb	1200 lb	
	24"	H1224824C	400 lb	H1204824C	500 lb	H1184824C	900 lb	1200 lb	
	30"	-	-	H1204830C	500 lb	H1184830C	750 lb	1200 lb	
	36"	-	-	H1204836C	500 lb	H1184836C	750 lb	1200 lb	

\* Class 3 Capacities are based upon the use of Extra Heavy Duty Shelves with (A) Side Shelf Supports and (B) Center Support for additional capacity. Must use nuts and bolts for shelves, not clips. All shelves are supplied with Erectomatic Clips. All shelf load capacities are in pounds for evenly distributed loads, and include a safety factor of 1.65.

### A. Class 3 Side Shelf Support (pairs)

Used to support Center Support in Class 3 applications.



Class 3 Side Shelf Support	
Unit Depth	Cat. No.
18"	1H830H
24"	1H840H
30"	1H850H
36"	1H860H

### B. Class 3 Center Support

Runs left to right beneath the mid-point of the shelf for conversion to Class 3. Supported by side shelf supports.



Class 3 Center Support	
Unit Width	Cat. No.
36"	H13736C
42"	H13742C
48"	H13748C



### The Cubic Advantage

With Erectomatic® Heavy Duty Modular Drawers in shelving you can effectively utilize your storage space above as well as below the drawers. By consolidating your bulk storage needs in the same floor space taken up by a conventional drawer cabinet unit, you can increase your storage capabilities up to 40% or more!

Heavy duty 100% full suspension allows full view of contents. Penco Modular Drawers can be installed at any level, and can be moved if your needs change. All heights and adjustments are on 1" centers, drawers can be interchanged and switched (2-3" drawers replace a 6" drawer etc.).

Can be used in units with either Hi-Performance or Standard Flange Shelves. For 36" Wide Shelving Units; Available for 18" & 24" depths.

### How To Order Modular Drawers For Shelving

- A.** Select the Drawer Kit that matches your needs, and then add the appropriate Drawer Interior Subdivision.
- B.** If you need to order from parts and accessories:
- 1) Select the size of mounting brackets.
  - 2) Order drawer front sizes that add up to the bracket size.
  - 3) Order partitions & dividers, plus any accessories sized to fit your application.
- C.** Color: Drawers, brackets and carriage are finished in Putty 3 or 028 Gray. Partitions are Gray.

NOTE: We strongly recommend that shelving with drawers installed be anchored to the floor. For Floor Anchoring Clip order Cat. No. 10006Z.

**NOT FOR USE WITH SHELVING DOORS**



Drawers in shelving provide a higher degree of organization for all the things you need to store. You can store items in random, family or sequential order.

### Modular Drawer Advantages

- 400 lb. capacity per drawer
- Improve inventory control
- Increased versatility
- Reduce inventory damage
- Economy through accessibility
- Efficient space utilization

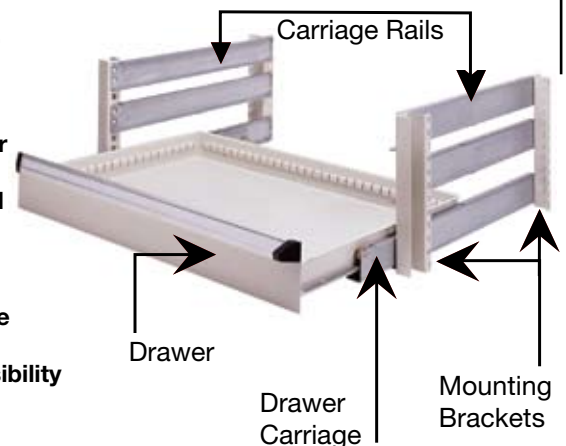



### Modular Drawers



All drawers are furnished complete with a heavy duty roller bearing carriage, carriage rails, extruded aluminum pull with built-in label holder, label, clear acetate label strip cover and hardware.

Capacity is 400 pounds, evenly distributed. 18" Deep Shelving has Interior Dimensions of 30" wide by 15" deep. 24" Deep Shelving has Interior Dimensions of 30" wide by 21" deep.

Note in the table below that drawer front heights, drawer body heights and usable drawer heights vary for different sizes.

Modular Drawers				
Drawer Front Height*	Drawer Body Height	Usable Drawer Height	18" Deep Cat. No.	24" Deep Cat. No.
3"	1-1/2"	2"	1MD301P	1MD307P
4"	2-1/2"	3"	1MD302P	1MD308P
5"	3-1/2"	4"	1MD303P	1MD309P
6"	4-1/2"	5"	1MD304P	1MD310P
8"	6-1/2"	7"	1MD305P	1MD311P

\* Actual drawer front height is 1/16" less.

### Mounting Bracket Kit



Includes four brackets and hardware for fastening to shelving posts.

Mounting Bracket	
Unit Height	Cat. No.
12"	1MK112P
18"	1MK118P
24"	1MK124P
36"	1MK136P

### Label Holder

Attaches to divider. Accepts 2-1/4" wide x 3/4" label.

Cat. No. 1M0009



### Partitions



Runs from front to rear to separate drawer from left to right. Accepts dividers in pre-punched slots.

Partitions		
Shelving Depth	Drawer Front Height	Cat. No.
18"	3"	1M336H
	4"	1M339H
	5"	1M338H
	6"	1M342H
24"	8"	1M345H
	3"	1M337H
	4"	1M340H
	5"	1M341H
24"	6"	1M343H
	8"	1M347H

### Plastic Bins



Sturdy gray molded plastic bin for small parts has built-in label holder.

Plastic Bins				
Drawer Front Ht.	Nom. Width	Nom. Depth	Nom. Height	Cat. No.
3"	2-1/2"	2-1/2"	1-1/2"	1M0001
	2-1/2"	5"	1-1/2"	1M0002
		5"	5"	1-1/2"
4"	2-1/2"	2-1/2"	2-1/2"	1M0004
	2-1/2"	5"	2-1/2"	1M0005
		5"	5"	2-1/2"

### Drawer Locking Mechanism

Contains two keyed alike built-in cylinder locks and prevents drawers from being opened. Supplied with two keys.\*\*

Drawer Lock	
Mnt. Bracket Height	Cat. No.
12"	1MK412
18"	1MK418
24"	1MK424
36"	1MK436

\*\* NOTE: If more than one set of brackets is used in a single shelving unit, contact your Penco representative for applicable locking mechanism.

### Dividers

Zinc plated dividers insert into slots for easy adjustment.



Dividers		
Drawer Front Height	No. of Slots Wide	Cat. No.
3"	4	1M0331
	5	1M0332
	6	1M0333
	7	1M0334
	8	1M0335
	10	1M0337
4"	11	1M0338
	4	1M0347
	5	1M0348
	6	1M0349
	7	1M0350
	8	1M0351
5"	10	1M0353
	11	1M0354
	4	1M0339
	5	1M0340
	6	1M0341
	7	1M0342
6"	8	1M0343
	10	1M0344
	11	1M0345
	4	1M0356
	5	1M0357
	6	1M0358
8"	7	1M0359
	8	1M0376
	10	1M0378
	11	1M0379
	4	1M0381
	5	1M0382
8"	6	1M0383
	7	1M0384
	8	1M0385
	10	1M0386
	11	1M0388

# Erectomatic®

## Modular Drawer Kits



### Modular Drawer Kits

All Erectomatic Modular Drawer Kits come complete with mounting brackets, drawer, carriage, rails, hardware and shelf closure strips necessary to install easily into new or existing Erectomatic shelving. All are available for 18" and 24" deep shelving. Drawer combinations shown are representative of the most popular configurations. See the Components page to design drawer combinations not shown.



#### Three Drawer Kit

Overall Height – 12"  
18" Deep - Cat. No. 1MK601P  
24" Deep - Cat. No. 1MK602P

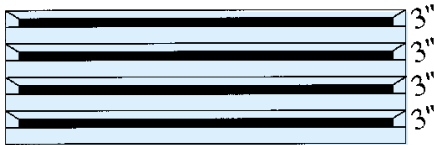

#### Four Drawer Kit

Overall Height – 12"  
18" Deep - Cat. No. 1MK603P  
24" Deep - Cat. No. 1MK604P

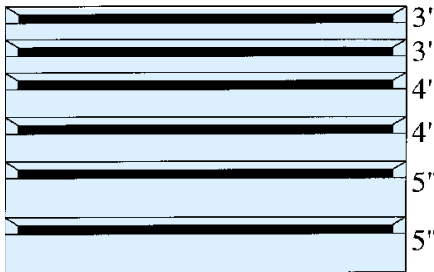

#### Six Drawer Kit

Overall Height – 24"  
18" Deep - Cat. No. 1MK605P  
24" Deep - Cat. No. 1MK606P

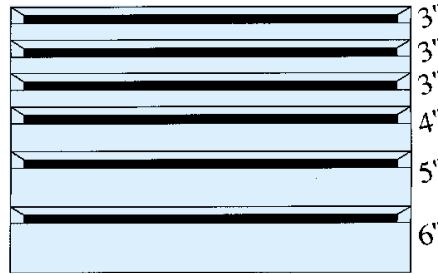

#### Six Drawer Kit

Overall Height – 24"  
18" Deep - Cat. No. 1MK607P  
24" Deep - Cat. No. 1MK608P

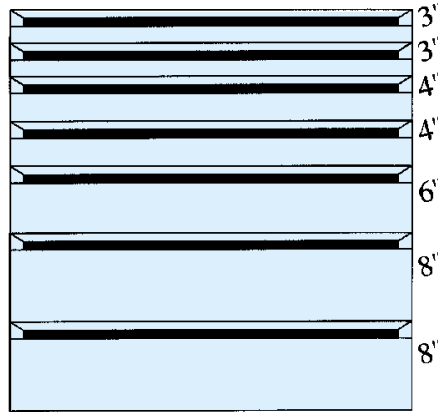

#### Seven Drawer Kit

Overall Height – 36"  
18" Deep - Cat. No. 1MK609P  
24" Deep - Cat. No. 1MK610P

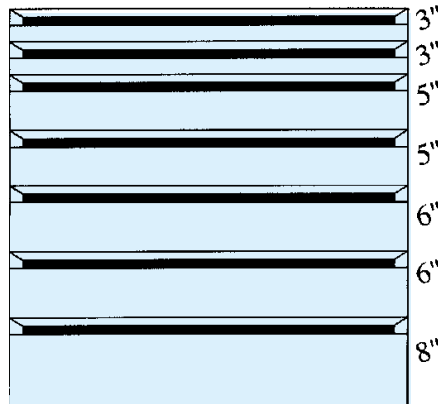

#### Seven Drawer Kit

Overall Height – 56"  
18" Deep - Cat. No. 1MK611P  
24" Deep - Cat. No. 1MK612P

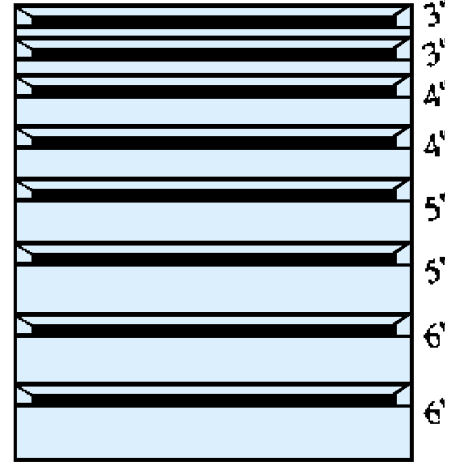

#### Eight Drawer Kit

Overall Height – 36"  
18" Deep - Cat. No. 1MK613P  
24" Deep - Cat. No. 1MK614P

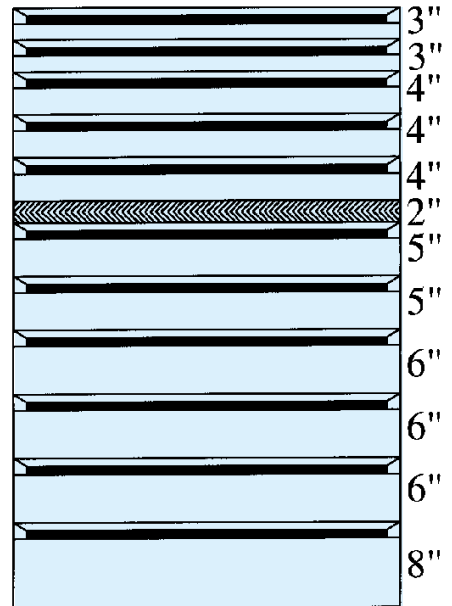

#### Eleven Drawer Kit

Overall Height – 56"  
18" Deep - Cat. No. 1MK615P  
24" Deep - Cat. No. 1MK616P

NOTE: All overall height dimensions do not include the shelves placed at the top and bottom of the drawers.

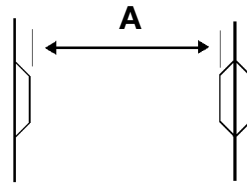

Compartment Width

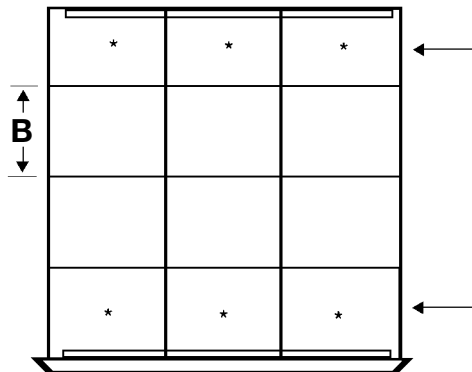

Compartment Depth

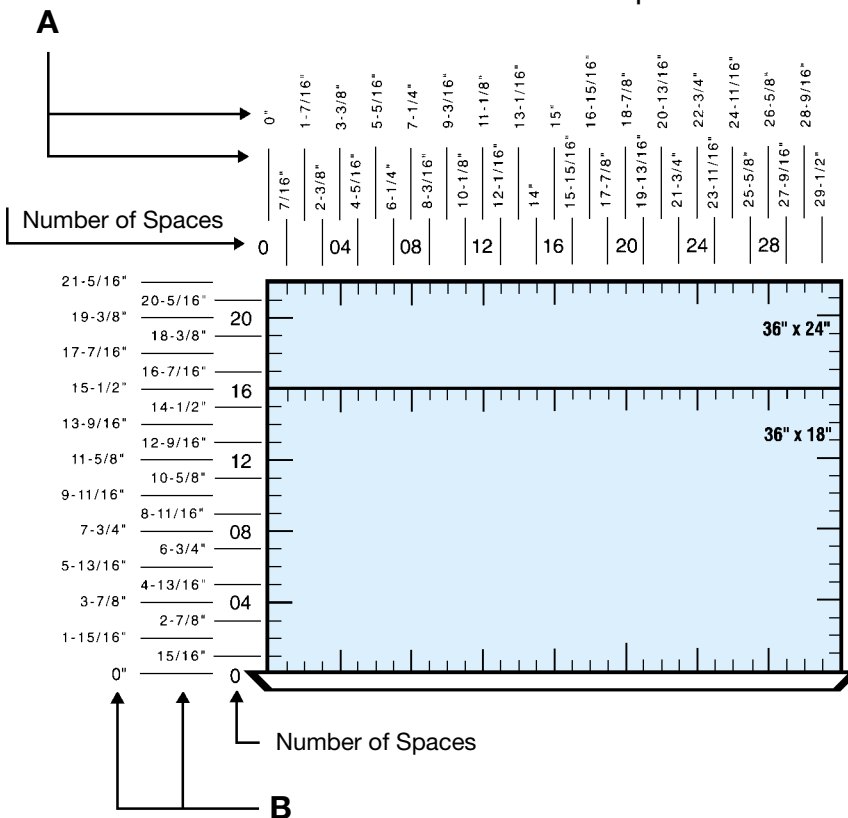

### Calculating Compartment Divisions

The slots in all sides of each drawer are on nominal 1" centers (.97"). Partitions, which are inserted from front to rear, have the same slot pattern as the sides. The diagram to the left enables you to figure the exact compartment sizes of interior subdivisions.

#### Compartment Width

$$A = (\text{number of spaces} \times 0.9688") - 0.500"$$

#### Compartment Depth

$$B = (\text{number of spaces} \times 0.9688") *$$

\* Subtract 1/4" each for compartments at the front and rear.

Organized storage of small parts is achieved by dividing the drawer body into smaller compartments. Illustrated on pages 22-23 are the most common configurations. To customize your own drawer compartments, order partitions and dividers separately. Compartment dimensions are clear opening sizes. Catalog numbers are provided for convenient ordering of partitions and dividers only. Order drawers separately. Partitions and dividers are not factory installed.

# Erectomatic®

## Modular Drawer Interior Subdivisions



### Interior Subdivisions for 18" Deep Shelving

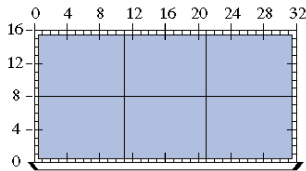

6 Compartments

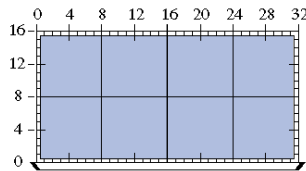

8 Compartments

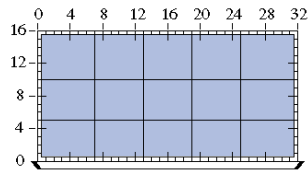

15 Compartments

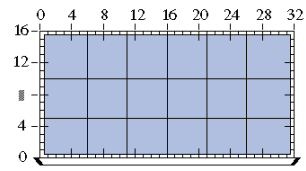

18 Compartments

### Interior Subdivisions for 24" Deep Shelving

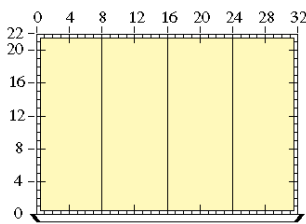

4 Compartments

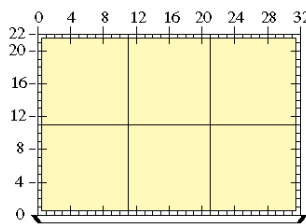

6 Compartments

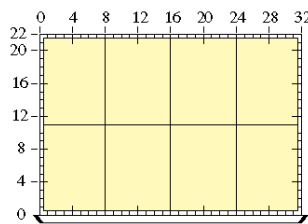

8 Compartments

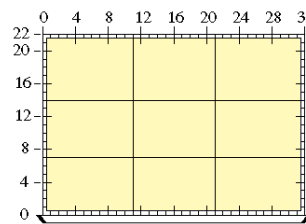

9 Compartments

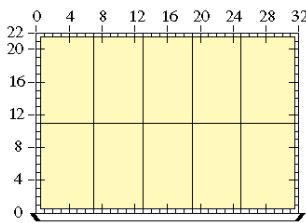

10 Compartments

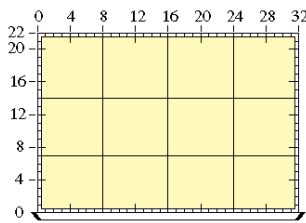

12 Compartments

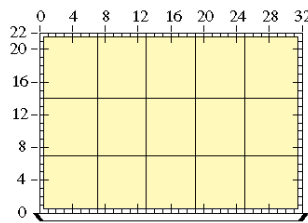

15 Compartments

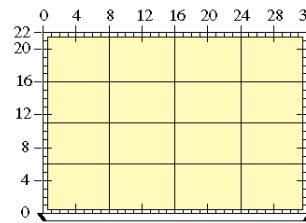

16 Compartments

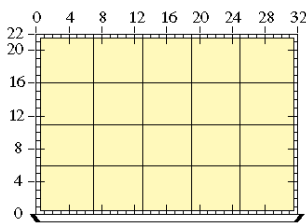

20 Compartments

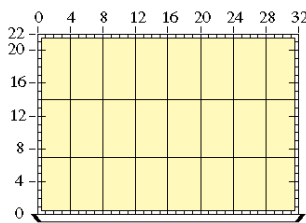

24 Compartments

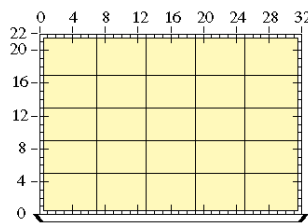

25 Compartments

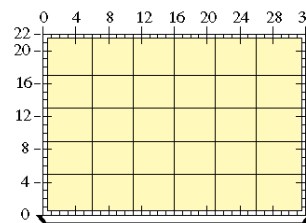

30 Compartments

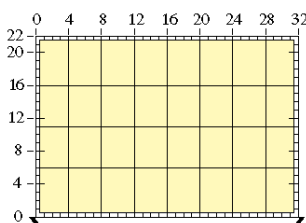

32 Compartments

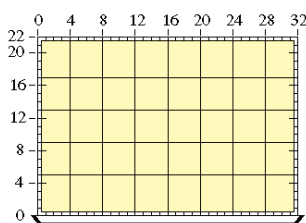

40 Compartments

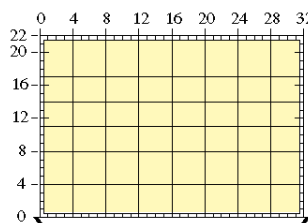

48 Compartments



### Interior Subdivisions for 18" Deep Shelving

Number of Compartments	3" Drawer Front Ht. Cat. No.	4" Drawer Front Ht. Cat. No.	5" Drawer Front Ht. Cat. No.	6" Drawer Front Ht. Cat. No.	8" Drawer Front Ht. Cat. No.
6	1MD013	1MD015	1MD014	1MD016	1MD017
8	1MD019	1MD021	1MD018	1MD022	1MD023
15	1MD025	1MD027	1MD026	1MD028	1MD029
18	1MD031	1MD033	1MD032	1MD034	1MD035

### Interior Subdivisions for 24" Deep Shelving

Number of Compartments	3" Drawer Front Ht. Cat. No.	4" Drawer Front Ht. Cat. No.	5" Drawer Front Ht. Cat. No.	6" Drawer Front Ht. Cat. No.	8" Drawer Front Ht. Cat. No.
4	1MD069	1MD071	1MD070	1MD072	1MD073
6	1MD103	1MD105	1MD104	1MD106	1MD107
8	1MD075	1MD077	1MD076	1MD078	1MD079
9	1MD111	1MD108	1MD127	1MD109	1MD110
10	1MD043	1MD045	1MD044	1MD046	1MD047
12	1MD081	1MD083	1MD082	1MD084	1MD085
15	1MD049	1MD051	1MD050	1MD052	1MD053
16	1MD087	1MD089	1MD088	1MD090	1MD091
20	1MD055	1MD057	1MD056	1MD058	1MD059
24	1MD092	1MD094	1MD128	1MD095	-
25	1MD061	1MD063	1MD062	1MD064	1MD065
30	1MD066	1MD067	1MD129	1MD068	-
32	1MD096	1MD097	1MD130	1MD098	-
40	1MD099	1MD101	1MD131	1MD102	-
48	1MD093	-	-	-	-

### Drawer Interior with Plastic Bins

For 18" Deep Shelves

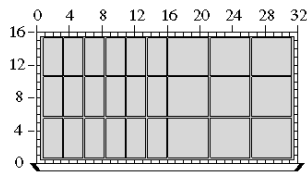

27 Plastic Bins

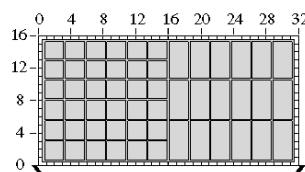

54 Plastic Bins

For 24" Deep Shelves

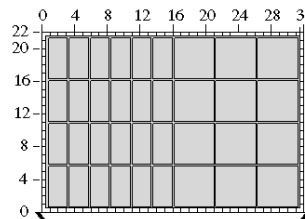

36 Plastic Bins

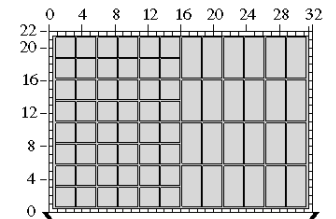

72 Plastic Bins

### Drawer Interior with Plastic Bins

For Shelf Depth	Number of Bins	3" Drawer Front Height Cat. No.	4" Drawer Front Height Cat. No.
18"	27	1MD116	1MD118
	54	1MD112	1MD114
24"	36	1MD124	1MD126
	72	1MD120	1MD122



### Penco Erectomatic Shelving Systems

Using standard components, Penco Erectomatic Shelving can be designed and configured to overcome a number of storage problems. By going UP and not OUT, tall shelving systems take advantage of factory space by capturing overhead area that is lighted, heated and paid for, while allowing valuable floor space to be used for more profitable activities.

With Erectomatic Flush Beaded Front Posts, or H-Posts for extreme loading and seismic applications, shelving systems can be built vertically. We can also supply pre-engineered components, elevated walkways, stair structures and handrails designed to meet local, state or federal codes. In Hi-Rise applications where free-path man-board order picking equipment is used, guide rail and cross-aisle top-ties are used to keep the structure sound.

Shelving systems can be designed as “closed” installations with solid backs and welded side panels, or as “open” style structures that are held together with side and rear sway bracing. For “pass through” order picking, H-Post with beams and a variety of decking choices are available.

All Penco Erectomatic High Performance Storage Systems are available with drawings that have been reviewed and approved by a structural engineer licensed in the state where the installation will take place.

### Free-Standing Custom Mezzanines/Work Platforms

Free-standing custom mezzanines can be designed to fit specific shape, size, height or load requirements. Custom mezzanines can be designed with longer spans while retaining a load rating to match the job’s requirement using structural steel components.

A variety of deck options are available such as Penco Channel Lock Safety Grating, bar grating, 1-1/2” B-Deck with plywood and diamond plate. For applications requiring a custom mezzanine, contact your Penco Sale Representative with your requirements.

Free-Standing Work Platform

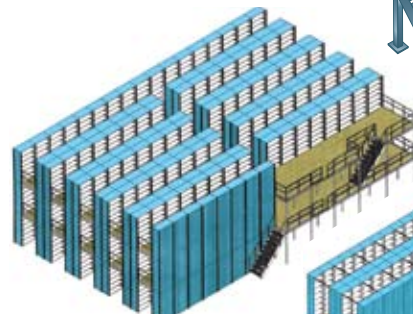
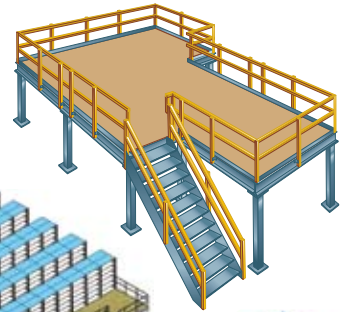

Three-Level Structure - 153 Units per Level

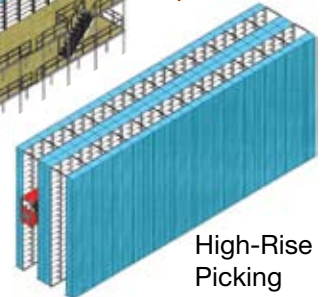

High-Rise Picking System

Shelving Supported Mezzanine/Work Platform

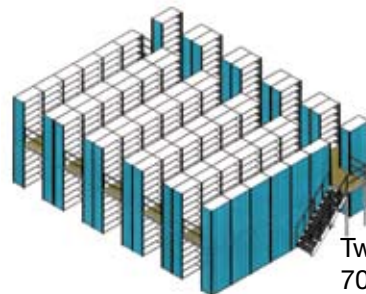
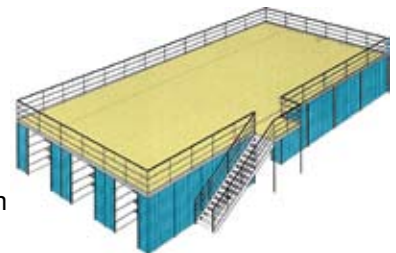

Two-Level Structure- 70 Units per Level





# Erectomatic®

## Multi-Level Shelving

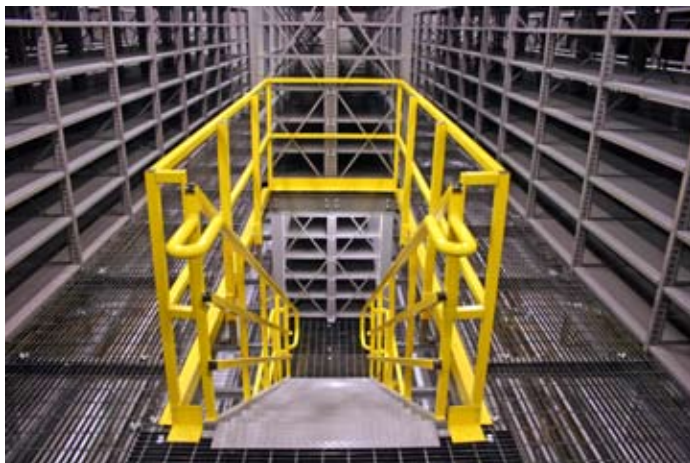

# Erectomatic®

## Channel-Lock Safety Grating



### For Mezzanines, Multi-Level Shelving, Catwalks & Platforms

**Safe.** Penco Safety Grating's standard slip-resistant surface contains hundreds of shoe-gripping nibs formed into the ribs to provide a safe, comfortable walking surface. The open design keeps small debris from accumulating, and allows passage of air and light.

**Strong.** The efficient Channel-Lock design achieves a very high strength-to-weight ratio with double flanges on each rib, and multiple flanges on each side channel for lateral strength. Since each piece is nested in adjacent planks, they actually strengthen one another. Each one-piece rigid plank is manufactured by a continuous roll-forming process capable of producing custom lengths up to 24 feet long.

**Economical.** Easy installation of Penco grating pays off in labor savings. Each plank is light enough for one person to carry. Cutting can be easily done with a hacksaw or power saw. All fastening can be done with standard tools - no welding is required, no special material handling equipment is required.

**The Advantages.** Penco grating is an extremely cost-efficient way to provide an elevated work surface. Its hot dipped galvanized corrosion-resistant coating insures long, safe life for interior or exterior applications.

Penco Channel-Lock Safety Grating is the ideal companion for multilevel installations made from Penco Erectomatic®, Clipper® or RivetRite® Shelving, or Penco Pallet Rack.

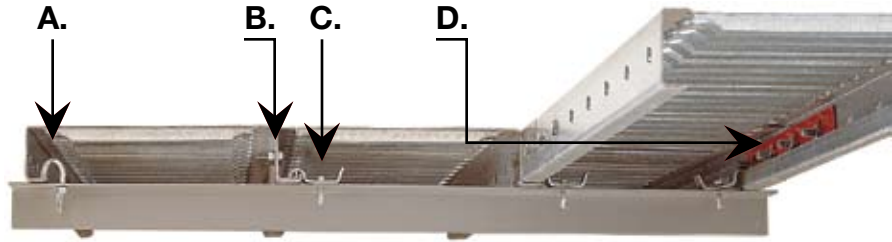



### Grating Accessories

Letter Code	Name	Description	Size	Cat. No.
A.	J-Bolt	Bag of 50 - Fastens grating to support structure.	5/16" Dia.	82200
B.	Bolts/Nuts	Bag of 50 - hex head bolts & nuts (use 4 per plank)	5/16" x 5/8"	82201
C.	Hold Down Clip	Fastens grating to support. Includes self-tapping screw.	-	8HC00H
D.	Splice	Holds grating together at outside edge of deck.	12"	8SP012

The grating shown below are the most popular sizes. All are 2" high by 8-7/8" wide, 16 gauge. Other gauges and sizes are available for large applications.

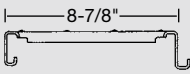
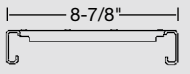
### Most Popular Grating Sizes

Grating Illustration	Grating Name	Application	Length	Cat. No.
	Male/ Female	Interlocks on both sides. Used for most applications.	72"	8AL072C
			108"	8AL108C
			144"	8AL144
	Male/ Male	Interlocks on one side only. For flush fit at edge of deck.	72"	8GL072C
			108"	8GL108C
			144"	8GL144
	Filler	To fill 3" wide gaps.	72"	8FK072C
			108"	8FK108C
			144"	8FK144



### Grating Capacity Table

Measurement	3'	4'	5'	6'	7'	8'	Point Load*	Weight Per Lin. Ft.	Weight Per Sq. Ft.
Uniform Load (U1)	668	374	238	164	119	-			
Deflection (D1)	0.11	0.19	0.29	0.42	0.57	-			
Uniform Load PSF(U2)	668	374	203	116	71	46			
Deflection at Above Load (D2)	0.11	0.19	0.25	0.3	0.35	0.4	110	3.11 lb	4.15 lb

16 gauge x 2" high. Unsupported span in feet. For capacities other than 2" high, 16 ga. grating, consult factory.

U1 = Uniform load in pounds per square foot for 9" wide plank (safe stress limit, no restriction on deflection).

D1 = Deflection in inches at load U1.

U2 = Uniform load in pounds per square foot for 9" wide plank (deflection restricted to length/240).

D2 = Deflection in inches at load U2.

\* Point Load = Maximum load in pounds for truck wheels each up to 2" wide by 8" diameter (for other types of concentrated loads, contact local representative).

To convert square feet to 9" wide linear feet: Multiply square feet x 1.35.  
to convert 9" wide linear feet to square feet: Multiply linear feet x .74.



# Erectomatic® Schmidt Stairs & WorkSafe™ Safety Products

## Stairs

All applications involving stairs are reviewed individually and designed to meet or exceed local, state and federal codes where the stairs are to be installed.

Side frames are made from heavy duty MC10 structural steel. Handrails and inner handrails are welded in place, and all parts are finished with durable powder coat paint.

GUARDRAIL CONSTRUCTED OF 1-1/2" SQ. x 14 GA. SQ. TUBE w/ 1-1/4" DIA. SCHEDULE 40 HANDRAIL @35° FROM TOP OF TREAD.

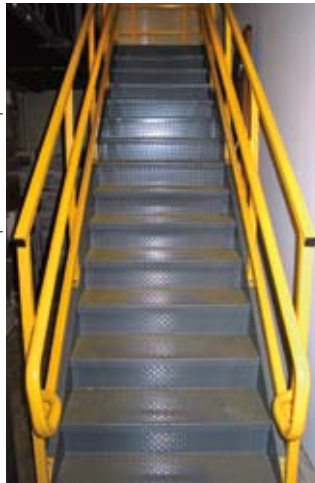
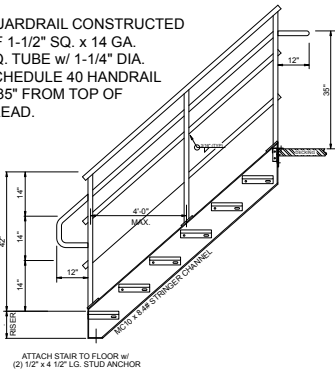

## Landings

Landings for stairs feature a heavy duty 1/8" diamond plate decking, handrail and kickplate on two sides and four column supports.

Two-column pedestal supported units are also available. Special sizes and baluster handrail is also available. All have a durable powdercoat finish.

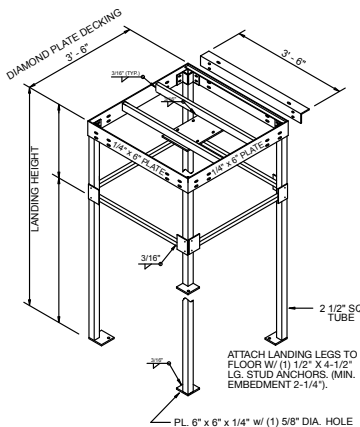

## Handrail, Kickplate & Gates

Welded tubular steel uprights and cross-rails with heavy gauge kickplate. Gates are available in swing, pivot corral and sliding configurations.



## Miscellaneous Safety Accessories

Penco's Schmidt Structural Products brand manufactures a wide variety of accessories for mezzanines and general plant use. All are finished with durable powder coat enamel in Safety Yellow.

### Barrier Rail

Protection for traffic aisles, personnel areas, machinery and structures. Available with permanent or removable rails.



### Sprinkler Guards

Protects sprinkler heads overhead from damage. 5/8" hot-rolled bar stock with 1/4" welded mounting plates.



### Bollards

Easy floor mounting with no concrete work needed. Instant protection for aisle ways, doors and equipment. Hardware included.



### Guide Rail

To protect areas adjacent to forklift aisles. Rugged 3/8" angle with pre-drilled mounting holes. Anchoring hardware included.



### Post Protectors

Rugged protection for pallet rack posts and building columns. Constructed of 1/4" thick plate with 4 anchoring feet - hardware included.



### Overhead Door Guards

Protects overhead door tracks from damage. Made from 1/4" steel plate. Complete with mounting hardware. Sold in pairs.



# Erectomatic®

## Shelving Specifications



**General:** All shelving shall comply with SMA and ANSI MH 28.1-1982 and in addition shall have the following characteristics:

**POSTS** - All posts shall be 14 gauge with 3/8" x 7/8" slots punched on 1-1/2" vertical centers for shelf adjustment using non-intrusive compression clips. Sway braces shall be attached to the post with nuts and bolts that shall not interfere with shelf adjustment.

**BEADED POST** - Shall be 14 gauge 11/16" wide x 2-9/16" deep overall. Units to have front beaded posts. Beaded posts used on open units shall have legs spot welded together on 6" centers for added strength. Legs shall be punched on 3" centers for the attachment of side sway braces.

**ANGLE POSTS** - Shall be 14 gauge side leg 2-5/16" wide, rear leg is 1-3/16". Post to be offset angle shape. Starter units shall have rear angle posts. Flanges shall be punched on 3" centers for the attachment of side and back sway braces.

**TEE POSTS** - Shall be two angle posts spot welded together on 6" centers. Adder units shall have rear T posts.

**END PANELS** - Closed starter units shall have end panels. Each end panel shall consist of one beaded post, one angle post and one 24 gauge side sheet spot welded on 6" centers.

**INTERMEDIATE PANELS** - Shall be the same as end panels except they shall have 2 angle posts and shall be furnished on closed adder units.

**BACKS** - Shall be 24 gauge with holes on 1" centers for bolting to angle or tee posts.

**SWAY BRACES** - Shall be 12 gauge x 3/4" wide ends punched for bolting to posts. Also punched in the middle for bolting to each other for strength and ease of installation.

**SHELF CLIP** - One piece 13 gauge compression type independently adjustable. Each clip shall bear on the edges of two post notches and provide a minimum of 1-1/2" of bearing. Zinc plated. Provide four independently adjustable clips per shelf.

**SHELVES** - Shelf shall have a 1-1/4" face on all four sides. Front and rear flanges shall have a 3/4" wide box formation with return flanges spot welded to the shelf bottom on 3" centers. Sides shall have a 5/8" 90° return flange. Corner shall be lapped and spot welded. Medium and heavy duty shelves shall have ribs in the tabs to keep shelf clips snug. Shelves shall be punched for dividers on 1-1/2" centers.

Shelves shall be furnished in medium duty, heavy duty or extra heavy duty to meet the specified capacity.

**SHELF REINFORCING** - Shall consist of 13 gauge side shelf supports tabbed to fit into clip slots and 14 gauge center shelf supports. Center support shall be held in place by engaging the side shelf supports. Shelf reinforcing shall be furnished when specified shelf capacity exceeds the rated capacity of the extra heavy duty shelf.

**SHELF DIVIDERS** - Shall be 24 gauge through 20" high; over 20" high dividers shall be 20 gauge. Fronts of dividers shall have a 5/16" diameter bead. Top, bottom and rear flanges shall be 7/8". Dividers shall be held in place with plastic buttons.

**ANGLE DIVIDERS** - Shall be 18 gauge and held in place with plastic buttons.

**SLIDING DIVIDERS** - Shall be 20 gauge. Divider portion shall be sloped at 45° at the front with a 1/2" radius at the front corner.

**BASE FRONT** - Shall be 18 gauge and attached to the shelf by bolting.

**BIN FRONTS** - Shall be 18 gauge and attached to the shelf by bolting. Bin fronts shall be 1", 2" or 3" high.

**FOOT PLATES** - Standard duty foot plate for Beaded, Angle and Tee Post foot plates shall be 2 1/4" x 3 1/2" x 12 ga. with a bracket welded on top. Plate has a 7/16" diameter hole for anchoring and an embossment for shim alignment.

Heavy duty foot plate for Beaded, Angle and Tee Post Footplates are 5 1/2" x 2 3/8" x 7 ga. with two brackets on top. Plate has two 7/16" diameter holes for anchoring.

**COUNTER TOPS** - Shall be 14 gauge with a 2" high face and 13 gauge counter end finishing caps attached with concealed nut and bolts.

**SHIMS** - Shims for use with standard duty foot plates shall be 2 1/4" x 3 1/2" and 16 ga., with 7/16" diameter hole and embossment same as for footplate.

Heavy duty foot plate shims for use with heavy duty foot plate and are 5 1/2" x 2-3/8" x 7 ga. Shim has two 7/16" holes that correspond with holes in the Heavy Duty Foot plate for anchoring.

**SWINGING DOORS** - Door and frame assembly complete with 3 point locking, chrome plated turn handle with built in lock with two keys. Doors are 20 gauge with reinforcing pans. Frames 16 gauge. Each pair of doors cover one shelving unit.

**SLIDING DOORS** - Shall be 22 gauge doors with 18 gauge reinforcing pans welded inside door. Includes a cylinder lock, 2 keys, nylon rollers and glides, and recessed handles. Side frame members shall be 20 gauge. Top and bottom frame member each shall be two piece 18 gauge assemblies. Sliding doors shall be 72" wide and cover two 36" wide shelving units.

**SHELF BOXES** - Shall be 20 gauge 4-5/8" high with an integral rigid curled handle on the box front. Box front and rear panel shall be punched for card holders, sides punched for 1" divider adjustment.

**SHELF BOX DIVIDER** - Shall be 20 gauge punched for card holders.

**POST SPLICE CHANNEL** - Shall be 16 gauge and formed into a channel shape. Center of channel shall be punched with three holes for assembling to upper and lower post. Used whenever posts are to be spliced to achieve added height.

**H-POST** - 14 gauge pickled and oiled steel. Post is 1-1/2" O.A. wide x 2-1/4" deep plus a rear flange of 11/16". Rear flange is punched with 5/16" diameter holes on one leg and 13/64" diameter holes on the opposite leg. Holes are on 3" centers for attaching sway braces or side panels.

**H-POST SIDE PANELS** - 24 gauge. Both vertical sides are punched with 9/32" x 9/16" slots on 3" centers.

**H-POST SPLICE** - 16 gauge with six 11/32" diameter holes. Part consists of two pieces each formed into a special channel shape and spot welded together. Assembly forms a splice with overall dimensions of 1-5/16" wide x 2-1/32" deep x 9 3/4" high.

**H-POST FOOT PLATE** - Heavy Duty foot plate consists of a 3-1/2" x 4" plate with four 7/16" diameter holes and a 12 gauge 2" wide channel 1 1/8" web with 1-3/4" legs. Channel web has a 5/8" diameter hole, each leg has a 9/32 x 7/16" slot. Channel is plug welded to the plate through the 5/8" diameter hole.

Light/medium duty foot plates are the same as above except the plate is 2-1/4" x 3-1/2" with one 7/16" diameter hole and one 3/8" diameter embossment.

**H-POST SIDE SWAY BRACES** - 12 gauge x 3/4" hot rolled pickled & oiled steel. Braces are punched at each end and in the middle with 3/16" diameter holes. Use 1/4 x 1/2" truss head bolts and hex nuts.

**SHIM PLATE HEAVY DUTY** - 4" x 3-1/2" x 16 gauge with two 7/16" diameter holes, one 27/32" long x 7/16" wide slot and one 3/8" diameter.

**SHIM PLATE LIGHT/MEDIUM DUTY** - 2-1/4" x 3-1/2" x 16 gauge with one 7/16" diameter hole and one 3/8" diameter embossment.

**CONNECTOR STRIPS** - Connector strips fasten to H-posts with Tek screws then the back panel is fastened to the connector strip. Starter unit connector strips are 14 gauge, 2-1/16" wide with two rows of 5/16" diameter holes on 1" centers. Adder unit connectors are 14 gauge, 3-1/8" wide with three rows of 5/16" diameter holes on 1" centers.

Erectomatic® and Hi-Performance® are registered trademarks of Penco Products, Inc.

PENCO RESERVES THE RIGHT TO VARY SPECIFICATIONS CONSISTENT WITH A POLICY OF CONTINUOUS PRODUCT IMPROVEMENT.



# Erectomatic®

## Installation Photos

A few of the many applications for Erectomatic Shelving



Two-level shelving with bottom serviced by picking machines.



Truck parts distribution center with guide rail.



Auto parts distribution center.



Archive storage in underground mine.



Two-level records center.



Distribution Warehouse for consumer goods producer.



NOTE: Colors shown are as close to actual finishes as the printing process allows. Do not make your final color selection based on the color shade shown on this page. Penco Color Charts are available for a more accurate color match. Exposure to high humidity, chlorine salts, abrasive cleaners, germicidal cleaners and acids can damage the finish and will void the guarantee. For outdoor applications or other harsh environmental conditions, contact your Penco Representative.

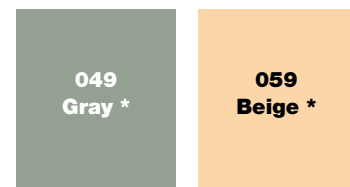

\* Historic colors to match old installations.

### Standard Colors

To assure rust resistance and paint adhesion, all Penco products receive a state of the art pre-paint conditioning that includes a thorough cleansing by a hot spray washing process, then a specially formulated coating is applied creating a surface that resists corrosion and improves paint adhesion. Erectomatic Shelving is available in the 24 colors shown above plus the two historic colors to match old installations.

### Standard Powder Coat Finish

Penco's standard 1 mil thick paint finish is perfect for most applications. The paint surface is tough and durable and offers a beautiful drip-free surface, excellent edge coverage and environmentally-friendly application.





## Industrial Shelving

Penco Products manufactures a wide variety of

shelving products. Clipper® and Erectomatic® Hi-Performance® shelving feature adjustable strong box beam shelves and post systems capable of supporting high-rise and multi-level installations. Wide Span shelving specializes in storing goods that are wide, high and bulky with extreme ease of assembly. RivetRite® boltless shelving's simple design offers an economical solution to most storage problems, from the small back room to the multi-level archive storage system.



## Pallet Rack

Penco pallet rack is a carefully engineered system designed to

provide highly efficient storage of palletized items. High strength steel and efficient design achieve a superior strength-to-weight ratio that makes Penco Rack one of the best values for your storage dollar. A wide range of sizes, capacities and accessories enables Penco pallet rack to handle virtually any job you can give it.



## Shop Furniture

Penco's products in the Shop Furniture line can make your work

environment more comfortable and efficient. Various configurations of work benches, carts and stools can be combined to help organize any work area for maximum productivity.



## Storage Cabinets

Penco's E-Z Bilt™ Cabinets are an ideal solution to storage

needs in offices, plants, schools and institutions. The contemporary design and attractive powder coat baked enamel finish is compatible with any decor. Design features include a recessed handle with built-in lock and two keys. Available in several models and sizes.



## Lockers

Penco Lockers have been a standard in the industry for

decades. They provide storage for school corridors, athletic team rooms, emergency responders, employees, health clubs and health care facilities. Penco steel lockers are beautifully finished in powder coat enamel in 24 decorator colors. Many sizes of Penco lockers are available on a QuickShip basis from our strategically located warehouses.





www.pencoproducts.com



Stack it, Store it, Secure it.

Also Manufactured by Penco



Clipper® Shelving



Pallet Rack



Wide Span Shelving



Shop Furniture



RivetRite® Shelving



Storage Cabintets

Affiliated Companies

Schmidt Structural Products, Inc.



Mezzanines  
Work Platforms • Stairs  
Facility Safety Products



All Star Bleachers, Inc.

Outdoor Spectator Seating  
Angle Frame Bleachers  
Team Benches  
[www.allstarbleachers.com](http://www.allstarbleachers.com)



Penco Products, Inc. • 2024 Cressman Road • Skippack, PA 19474

Phone: 800-562-1000 • Fax: 800-248-1555 • E-MAIL: [general@pencoproducts.com](mailto:general@pencoproducts.com)



This catalog was printed on paper made in the USA.

© Copyright 2012 Penco Products, Inc.  
ErectomaticCatalog1-2012.indd/pdf RPI 2.5M