

# EnviroGT G2-6000 Bed Locator

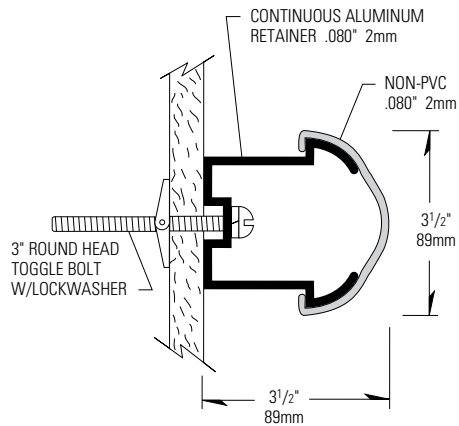

- ▶ Non-PVC cover is manufactured with G2 blend BioPoly-PETG+, InPro's exclusive reformulated PETG made with a corn-based biopolymer and recycled content
- ▶ Available in 100 standard colors and 11 Global Colours
- ▶ Allows for quick positioning of beds while preventing damage to walls
- ▶ Offers easy installation with pre-cut system
- ▶ Meets the most rigorous standards and criteria of chemical emissions as prescribed by the GREENGUARD Environmental Institute
- ▶ Has been tested and meets GREENGUARD Environmental Institute's and the state of California's requirements for low emitting products as tested by Air Quality Sciences
- ▶ Has been tested and meets the GREENGUARD Children & School chemical emissions levels

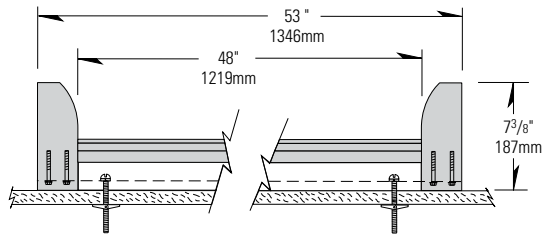

IPC.1175/REV.2

P.O. Box 406 · Muskego, Wisconsin 53150 USA  
 inprocorp.com  
 Nationwide 800.222.5556/Fax 888.715.8407  
 International Sales 262.679.5521/Fax 262.679.5524



# EnviroGT G2-6000 Bed Locator

## Suggested Specifications

---

### PART 1 – GENERAL

#### 1.01 SUMMARY

- A. Non PVC bed locator system for wall protection and decoration

#### 1.02 SECTION INCLUDES

- A. G2-6000 Bed Locator Systems

#### 1.03 REFERENCES

- A. American National Standards Institute (ANSI)  
B. American Society for Testing and Materials (ASTM)  
C. National Fire Protection Association (NFPA)  
D. Society of Automotive Engineers (SAE)

#### 1.04 SYSTEM DESCRIPTION

- A. Performance Requirements: Provide bed locator systems that conform to the following requirements of regulatory agencies and the quality control of IPC Door and Wall Protection Systems, InPro Corporation.
1. Fire Performance Characteristics: Provide bed locator conforming with the NFPA Class A fire rating. Surface burning characteristics, as determined by ASTM E-84, shall be flame spread of 25 or less and smoke development of 450 or less.
2. Impact Strength: Provide profile materials that have been tested in accordance with the applicable provisions of ASTM D-256, Impact Resistance of Plastics.
3. Chemical and Stain Resistance: Provide material that shows resistance to stain when tested in accordance with applicable provisions of ASTM D-543.
4. Fungal and Bacterial Resistance: Provide material that does not support fungal or bacterial growth as tested in accordance with ASTM G-21 and ASTM G-22.
5. GREENGUARD Certified: Provide GREENGUARD Certified profiles. Profiles shall meet the requirements of GREENGUARD Certification Standards for Low-Emitting Products and GREENGUARD Product Emission Standard for Children & Schools.
6. Color Consistency: Provide components matched in accordance with SAE J-1545 - (Delta E) with a color difference no greater than 1.0 units using CIE Lab, CIE CMC, CIE LCh, Hunter Lab or similar color space scale systems.

#### 1.05 SUBMITTALS

- A. Product Data: Manufacturer's printed product data for each product indicated in this section.
- B. Detail Drawings: Mounting details with the appropriate fasteners for specific project substrates.
- C. Samples: Verification samples of bed locator, 8" (203mm) long, in full size profiles of each type and color indicated.
- D. Manufacturer's Installation Instructions: Printed installation instructions for each bed locator.

#### 1.06 DELIVERY, STORAGE AND HANDLING

- A. Deliver materials in unopened factory packaging to

the jobsite

- B. Inspect materials at delivery to assure that specified products have been received.
- C. Store in original packaging in a climate controlled location away from direct sunlight.

#### 1.07 PROJECT CONDITIONS

- A. Environmental Requirements: Install products in an interior climate controlled environment.

#### 1.08 WARRANTY

- A. Standard IPC Limited Lifetime Warranty against material and manufacturing defects.

### PART 2 – PRODUCTS

#### 2.01 MANUFACTURER

- A. Acceptable Manufacturer: IPC Interior Protection Products and Decorative Surfaces, InPro Corporation, PO Box 406, Muskego, WI 53150, USA; Telephone: 800.222.5556, Fax: 888.715.8407, www.inprocorp.com
- B. Substitutions: Not permitted
- C. Provide all bed locator and wall protection from a single manufacturer.

#### 2.02 LEED CRITERIA

- A. Provide bed locator systems with components that have recycled content.
1. MR Credit 4.1, 10%(post-consumer + ½ pre-consumer), 1 credit
2. MR Credit 4.2, 20%(post-consumer + ½ pre-consumer), 1 credit

#### 2.03 MANUFACTURED UNITS

- A. Bed Locator Profile
1. G2-6000 Bed Locator Profile, Dimension: 3-1/2" (89mm) height x 3-1/2" (89mm), Standard Length: 53" (1.35m)
- 2.04 MATERIALS
- A. Reformulated PETG with Biopolymer Blend: Snap on cover of .080" (2mm) thickness shall be extruded from chemical and stain resistant PETG.
- B. Aluminum: Continuous aluminum retainer of .080" (2mm) thickness shall be fabricated from 6063-T5 aluminum with a mill finish.

#### 2.05 COMPONENTS

- A. End Caps shall be made of injection molded thermoplastics.
- B. Fasteners: All mounting system accessories appropriate for substrates indicated on the drawing shall be provided.

#### 2.06 FINISHES

- A. Bed Locator Covers: Bed locator colors to be selected

by the architect from the IPC finish selection.

- B. Molded components: End Caps shall be of a color matching the bed locator. Surface shall have a pebblette texture.

### PART 3 – EXECUTION

#### 3.01 EXAMINATION

- A. Examine areas and conditions in which the bed locator system will be installed.
1. Complete all finishing operations, including painting, before beginning installation of bed locator system materials.
2. Wall surface shall be dry and free from dirt, grease and loose paint.

#### 3.02 PREPARATION

- A. General: Prior to installation, clean substrate to remove dust, debris and loose particles.

#### 3.03 INSTALLATION

- A. General: Locate bed locator as indicated on approved detail drawings for the appropriate substrate and in compliance with the IPC installation instructions. Install bed locator level and plumb at the height indicated on the drawings.
- B. Installation of G2-6000 Bed Locator:
1. Attach an end cap on each side of the aluminum retainer. Simply slide the end cap onto the aluminum retainer until the two holes of the end cap line up with the two holes of the aluminum retainer. Fasten the end caps by using two 1/4" screws per end cap.
2. Position aluminum retainer with the end caps attached, against the wall at the desired height. After checking to see that the retainer is level, transfer the locations of the mounting holes to the wall with a marker. Remove aluminum retainer and drill all marked holes on the wall with a 3/4" drill bit.
3. Loosely attach mounting bolts to the aluminum retainer (one 1/4" x 3" round head bolt, one 1/4" lock washer and one toggle wing per hole). Mount the assembled retainer into the holes on the wall. Level the retainer and tighten the bolts to secure the retainer to the wall.
4. Position the cover on the aluminum retainer starting at the top of the retainer and pivoting the cover over the bottom of the retainer until it snaps into place.

#### 3.04 CLEANING

- A. At completion of the installation, clean surfaces in accordance with the IPC clean-up and maintenance instructions.