

# EnviroGT G2-200 Wall Guard

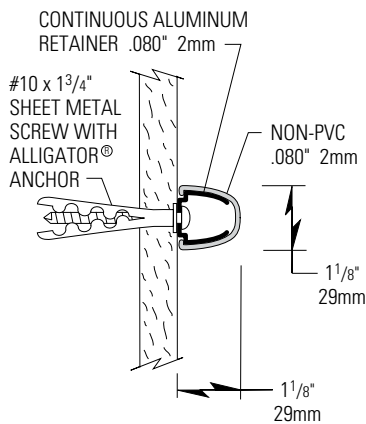

- ▶ Non-PVC cover is manufactured with BioPolyPETG+, InPro's exclusive reformulated PETG made with a corn-based biopolymer and recycled content
- ▶ Target specific problems area with a narrow profile
- ▶ Offer continuous protection with industry exclusive inside and outside corners
- ▶ Minimize seams with standards 12' lengths
- ▶ Coordinate interiors with 100 standard colors and 11 Global Colours
- ▶ Meets the most rigorous standards and criteria of chemical emissions as prescribed by the GREENGUARD Environmental Institute
- ▶ Has been tested and meets GREENGUARD Environmental Institute's and the state of California's requirements for low emitting products as tested by Air Quality Sciences
- ▶ Has been tested and meets the GREENGUARD Children & School chemical emissions levels

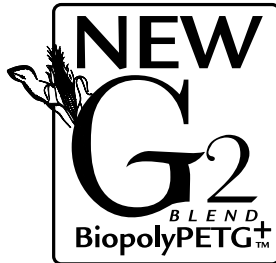

IPC.1154/REV.1



P.O. Box 406 · Muskego, Wisconsin 53150 USA  
 inprocorp.com  
 Nationwide 800.222.5556/Fax 888.715.8407  
 International Sales 262.679.5521/Fax 262.679.5524

**INPRO CORPORATION**  
 Interior and Exterior Architectural Products

# EnviroGT G2-200 Wall Guard

## Suggested Specifications

### PART 1 – GENERAL

#### 1.01 SUMMARY

- A. Non PVC Wall Guard system for wall protection and decoration

#### 1.02 SECTION INCLUDES

- A. G2-200 Wall Guard Systems

#### 1.03 REFERENCES

- A. American National Standards Institute (ANSI)  
B. American Society for Testing and Materials (ASTM)  
C. National Fire Protection Association (NFPA)  
D. Society of Automotive Engineers (SAE)

#### 1.04 SYSTEM DESCRIPTION

- A. Performance Requirements: Provide wall guard systems that conform to the following requirements of regulatory agencies and the quality control of IPC Door and Wall Protection Systems, InPro Corporation.
1. Fire Performance Characteristics: Provide material conforming with the NFPA Class A fire rating. Surface burning characteristics, as determined by ASTM E-84, shall be flame spread of 25 or less and smoke development of 450 or less.
  2. Impact Strength: Provide profile materials that have been tested in accordance with the applicable provisions of ASTM D-256, Impact Resistance of Plastics.
  3. Chemical and Stain Resistance: Provide material that shows resistance to stain when tested in accordance with applicable provisions of ASTM D-543.
  4. Fungal and Bacterial Resistance: Provide material that does not support fungal or bacterial growth as tested in accordance with ASTM G-21 and ASTM G-22.
  5. GREENGUARD Certified: Provide GREENGUARD Certified material. Profiles shall meet the requirements of GREENGUARD Certification Standards for Low-Emitting Products and GREENGUARD Product Emission Standard for Children & Schools.
  6. Color Consistency: Provide components matched in accordance with SAEJ-1545 - (Delta E) with a color difference no greater than 1.0 units using CIE Lab, CIE CMC, CIE LCh, Hunter Lab or similar color space scale systems.

#### 1.05 SUBMITTALS

- A. Product Data: Manufacturer's printed product data for each product indicated in this section.  
B. Detail Drawings: Mounting details with the appropriate fasteners for specific project substrates.  
C. Samples: Verification samples of wall guard, 8" (203mm) long, in full size profiles of each type and color indicated.  
D. Manufacturer's Installation Instructions: Printed installation instructions for each wall guard.

#### 1.06 DELIVERY, STORAGE AND HANDLING

- A. Deliver materials in unopened factory packaging to the jobsite  
B. Inspect materials at delivery to assure that specified products have been received.  
C. Store in original packaging in a climate controlled location away from direct sunlight.

#### 1.07 PROJECT CONDITIONS

- A. Environmental Requirements: Install products in an interior climate controlled environment.

#### 1.08 WARRANTY

- A. Standard IPC Limited Lifetime Warranty against material and manufacturing defects.

### PART 2 – PRODUCTS

#### 2.01 MANUFACTURER

- A. Acceptable Manufacturer: IPC Interior Protection Products and Decorative Surfaces, InPro Corporation, PO Box 406, Muskego, WI 53150, USA; Telephone: 800.222.5556, Fax: 888.715.8407, www.inprocorp.com  
B. Substitutions: Not permitted  
C. Provide all wall guard and wall protection from a single manufacturer.

#### 2.02 LEED CRITERIA

- A. Provide wall guard systems with components that have recycled content.
1. MR Credit 4.1, 10%(post-consumer + ½ pre-consumer), 1 credit
  2. MR Credit 4.2, 20%(post-consumer + ½ pre-consumer), 1 credit

#### 2.03 MANUFACTURED UNITS

- A. Wall Guard Profile
1. G2-200 Wall Guard, 1-1/8" (29mm) height x 1-1/8" (29mm) depth

#### 2.04 MATERIALS

- A. Reformulated PETG with Biopolymer Blend: Snap on cover of .080" (2mm) thickness shall be extruded from chemical and stain resistant PETG.  
B. Aluminum: Continuous aluminum retainer of .080" (2mm) thickness shall be fabricated from 6063-T5 aluminum with a mill finish.

#### 2.05 COMPONENTS

- A. End Caps, inside corners and outside corners shall be made of injection molded thermoplastics.  
B. Fasteners: All mounting system accessories appropriate for substrates indicated on the drawing shall be provided.

#### 2.06 FINISHES

- A. Wall Guard Covers: Wall guard colors to be selected by the architect from the IPC finish selection.

- B. Molded components: End Caps, inside corners and outside corners shall be of a color matching the wall guards. Surface shall have a pebblette texture.

### PART 3 – EXECUTION

#### 3.01 EXAMINATION

- A. Examine areas and conditions in which the wall guard system will be installed.
1. Complete all finishing operations, including painting, before beginning installation of wall guard system materials.
  2. Wall surface shall be dry and free from dirt, grease and loose paint.

#### 3.02 PREPARATION

- A. General: Prior to installation, clean substrate to remove dust, debris and loose particles.

#### 3.03 INSTALLATION

- A. General: Locate wall guard as indicated on approved detail drawings for the appropriate substrate and in compliance with the IPC installation instructions. Install wall guard level and plumb at the height indicated on the drawings.
- B. Installation of G2-200 Wall Guard:
1. Cut the aluminum retainer to the desired length, allowing 1-1/8" (29mm) for each end cap, flush for each outside corner and 1-9/16" (40mm) for each inside corner.
  2. Using a 1/4" drill bit, drill holes in the centerline of the aluminum retainer 4" (102mm) from each end and spaced evenly over the entire length (6 anchors per 12' (3.66m) length).
  3. Position and level the aluminum retainer on the wall, allowing for end caps and corners, and transfer mounting holes to the wall with a marker. Drill 1/4" (6mm) holes at each mark and position the ALLIGATOR anchors into the holes on the wall. Mount the retainer with #10 x 1-3/4" phillips pan head screws and tighten the screws to secure the retainer.
  4. Slide the end caps and corners onto the aluminum, leaving a 1/16" gap for adjustments, and secure them by using one 1-1/4" self-tapping screw per end cap or two per corner.
  5. Cut the vinyl cover to the distance between the end caps/corners. NOTE: Trim all factory edges square before installation. Position the vinyl cover on the aluminum retainer starting at one end and working to the other end by pushing the cover over the aluminum until it snaps into place.

#### 3.04 CLEANING

- A. At completion of the installation, clean surfaces in accordance with the IPC clean-up and maintenance instructions.

