

Aluminum Corner Guards

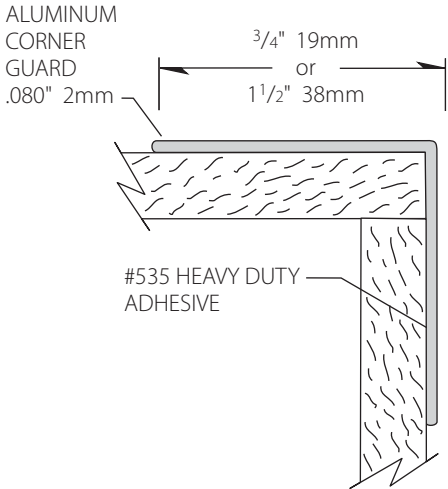

Aluminum Corner Guard

- 3/4" (19mm) wing, 1 1/2" (38mm) wing
- Manufactured in 4' (1.22m) and 8' (2.44m) standard heights,
- Manufactured from 5005-H34 aluminum
- Clear anodized finish

IPC.1376/REV.1

Aluminum Corner Guard

Suggested Specifications

PART 1 – GENERAL

1.01 SUMMARY

A. Corner guard system for wall protection:

1.02 SECTION INCLUDES

A. Aluminum Corner Guard Systems

1.03 SUBMITTALS

A. Product data for each type of corner guard specified.

B. Detail drawings indicating mounting details with the appropriate adhesives for specific project substrates.

C. Samples for verification purposes of corner guard, 6" (152mm) long, in full size profiles of each type indicated.

D. Cleaning and maintenance instructions for door and wall protection systems.

1.04 DELIVERY, STORAGE AND HANDLING

A. Deliver materials in unopened factory packaging to the jobsite and store in original packaging in a climate controlled location away from direct sunlight.

1.05 PROJECT CONDITIONS

A. Products must be installed in an interior climate controlled environment.

1.06 WARRANTY

A. Standard IPC Limited Lifetime Warranty against material and manufacturing defects.

PART 2 - PRODUCTS

2.01 MANUFACTURER

A. Acceptable Manufacturer: IPC Door and Wall Protection Systems, InPro Corporation, PO Box 406 Muskego, WI 53150 USA; Telephone: 800.222.5556, Fax: 888.715.8407, www.inprocorp.com

B. Substitutions: Not permitted

C. Provide all corner guards and wall protection from a single source.

2.02 MANUFACTURED UNITS

A. Corner Guards

1. Aluminum Corner Guards

Size

3/4"(19mm) x 3/4"(19mm) x .080"(2.3mm) thick

1-1/2"(38mm) x 1-1/2"(38mm) x .080"(2.3mm) thick

Length: 4' (1.21m) and 8' (2.43m)

Attachment - #535 Heavy Duty Adhesive

2.03 MATERIALS

A. Aluminum: Aluminum Corner Guards shall be manufactured from 5005-H34 aluminum,

2.04 COMPONENTS

A. Attachment

1. Adhesive: Field applied heavy-duty adhesive.

2.05 FINISHES

A. Aluminum corner guards shall have a clear anodized finish. Finish shall be to 204R1 specification.

PART 3 - EXECUTION

3.01 EXAMINATION

A. Examine areas and conditions in which the corner guard systems will be installed.

1. Complete all finishing operations, including painting, before beginning installation of corner guards.

B. Wall surface shall be dry and free from dirt, grease and loose paint.

3.02 PREPARATION

A. General: Prior to installation, clean substrate to remove dust, debris and loose particles.

3.03 INSTALLATION

A. General: Locate the corner guard as indicated on the approved detail drawing for the appropriate substrate and in compliance with the IPC installation instructions. Install corner guard level and plumb at the height indicated on the drawings.

B. Installation of Aluminum Corner Guards:

1. Surface must be dry, clean and properly sealed.

2. Apply a bead of PL Premium Heavy Duty Adhesive in a zigzag pattern over the back of each wing of the corner guard. Position corner guard on the wall and apply pressure until a tight fit is achieved.

3. Remove the protective plastic covering from the exposed surface of the corner guard.

3.04 CLEANING

A. At completion of the installation, clean surfaces in accordance with the IPC clean up and maintenance instructions.