

Stainless Steel

Corner Guards

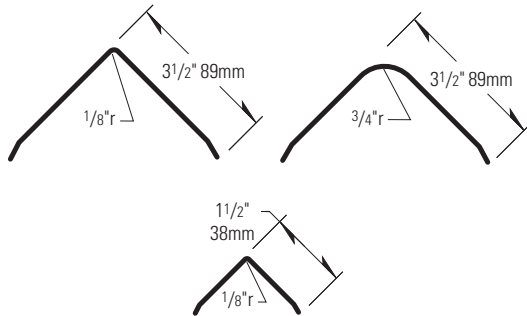

Stainless Steel



Stainless Steel

- Provides 3 1/2" (89mm) wing, 1 1/2" (38mm) wing. Custom wing sizes and angles also available
- Manufactured in 4' (1.22m) and 8' (2.44m) standard heights, custom heights available
- Standard Type 430 available in standard 16-gauge, also available in 14- and 18-gauge
- Standard Type 304 (Meets NSF Standard 51) available in 16-gauge, also available in 14-gauge
- Available in No. 4 Satin Finish

Gold Titanium Stainless Steel

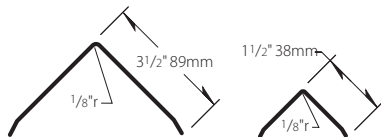

Gold Titanium (Custom)

- Provides 3 1/2" (89mm) and 1 1/2" (38mm) wings
- Manufactured in custom heights only
- Standard Type 304, 18-gauge available
- Available in Gold Titanium, Mirror Finish

IPC.438/REV.9

Stainless Steel Corner Guards

Suggested Specifications

PART 1 – GENERAL

1.01 SUMMARY

A. Corner guard system for wall protection:

1.02 SECTION INCLUDES

A. Stainless Steel Corner Guard Systems

1.03 SUBMITTALS

A. Product data for each type of corner guard specified.

B. Detail drawings indicating mounting details with the appropriate fasteners for specific project substrates.

C. Samples for verification purposes of corner guard, 6" (152mm) long, in full size profiles of each type and color indicated.

D. Cleaning and maintenance instructions for door and wall protection systems.

1.04 DELIVERY, STORAGE AND HANDLING

A. Deliver materials in unopened factory packaging to the jobsite and store in original packaging in a climate controlled location away from direct sunlight.

1.05 PROJECT CONDITIONS

A. Products must be installed in an interior climate controlled environment.

1.06 WARRANTY

A. Standard IPC Limited Lifetime Warranty against material and manufacturing defects.

PART 2 - PRODUCTS

2.01 MANUFACTURER

A. Acceptable Manufacturer: IPC Door and Wall Protection Systems, InPro Corporation, PO Box 406 Muskego, WI 53150 USA; Telephone: 800.222.5556, Fax: 888.715.8407, www.inprocorp.com

B. Substitutions: Not permitted

C. Provide all corner guards and wall protection from a single source.

2.02 MANUFACTURED UNITS

A. Corner Guards

1. Stainless Steel Corner Guards

Model, Size, Attachment Method, Grade, Thickness

181124C-304, 1 1/2" (38mm) x 1 1/2" (38mm) x 48" (1.21m), 1/8" radius, Cement-on, 304 Stainless Steel, 16 gauge

181128C-304, 1 1/2" (38mm) x 1 1/2" (38mm) x 96" (2.43m), 1/8" radius, Cement-on, 304 Stainless Steel, 16 gauge

18112H-304, 1 1/2" (38mm) x 1 1/2" (38mm) x 48" (1.21m), 1/8" radius, Screw-on, 304 Stainless Steel, 16 gauge

181128H-304, 1 1/2" (38mm) x 1 1/2" (38mm) x 96" (2.43m), 1/8" radius, Screw-on, 304 Stainless Steel, 16 gauge

181124C-430, 1 1/2" (38mm) x 1 1/2" (38mm) x 48" (1.21m), 1/8" radius, Cement-on, 430 Stainless Steel, 16 gauge

181128C-430, 1 1/2" (38mm) x 1 1/2" (38mm) x 96" (2.43m), 1/8" radius, Cement-on, 430 Stainless Steel, 16 gauge

18112H-430, 1 1/2" (38mm) x 1 1/2" (38mm) x 48" (1.21m), 1/8" radius, Screw-on, 430 Stainless Steel, 16 gauge

181128H-430, 1 1/2" (38mm) x 1 1/2" (38mm) x 96" (2.43m), 1/8" radius, Screw-on, 430 Stainless Steel, 16 gauge

183124C-304, 3 1/2" (89mm) x 3 1/2" (89mm) x 48" (1.21m), 1/8" radius, Cement-on, 304 Stainless Steel, 16 gauge

183124C-304, 3 1/2" (89mm) x 3 1/2" (89mm) x 96" (2.43m), 1/8" radius, Cement-on, 304 Stainless Steel, 16 gauge

183124H-304, 3 1/2" (89mm) x 3 1/2" (89mm) x 48" (1.21m), 1/8" radius, Screw-on, 304 Stainless Steel, 16 gauge

183124H-304, 3 1/2" (89mm) x 3 1/2" (89mm) x 96" (2.43m), 1/8" radius, Screw-on, 304 Stainless Steel, 16 gauge

183124C-430, 3 1/2" (89mm) x 3 1/2" (89mm) x 48" (1.21m), 1/8" radius, Cement-on, 430 Stainless Steel, 16 gauge

183124C-430, 3 1/2" (89mm) x 3 1/2" (89mm) x 96" (2.43m), 1/8" radius, Cement-on, 430 Stainless Steel, 16 gauge

183124H-430, 3 1/2" (89mm) x 3 1/2" (89mm) x 48" (1.21m), 1/8" radius, Screw-on, 430 Stainless Steel, 16 gauge

183124H-430, 3 1/2" (89mm) x 3 1/2" (89mm) x 96" (2.43m), 1/8" radius, Screw-on, 430 Stainless Steel, 16 gauge

Available custom options: Height, wing size, 3/4" bullnose radius, 14 gauge, 18 gauge, gold titanium.

2.03 MATERIALS

A. Stainless Steel: Corner Guards shall be manufactured from Type 430, 16 gauge Stainless Steel, options: Type 430, 14 and 18 gauge; Type 304 (meets NSF Standard 51), 16 and 14 gauge

B. Gold Titanium Stainless Steel: Corner Guards shall be manufactured from Type 304, 18 gauge stainless steel with a titanium gold surface.

2.04 COMPONENTS

A. Attachment

1. Adhesive: Field applied heavy duty adhesive

2. Fasteners: Pre-drilled beveled holes and phillips head screws.

2.05 FINISHES

A. Stainless steel: No. 4 satin finish.

B. Gold Titanium Stainless steel: mirror finish.

PART 3 - EXECUTION

3.01 EXAMINATION

A. Examine areas and conditions in which the corner

guard systems will be installed.

1. Complete all finishing operations, including painting, before beginning installation of corner guards.

B. Wall surface shall be dry and free from dirt, grease and loose paint.

3.02 PREPARATION

A. General: Prior to installation, clean substrate to remove dust, debris and loose particles.

3.03 INSTALLATION

A. General: Locate the corner guard as indicated on the approved detail drawing for the appropriate substrate and in compliance with the IPC installation instructions. Install corner guard level and plumb at the height indicated on the drawings.

B. Installation of Stainless Steel Corner Guards:

1. Surface must be dry, clean and properly sealed.

2. Cement on: Apply a bead of PL Premium Heavy Duty Adhesive in a zigzag pattern over the back of each wing of the corner guard. Position corner guard on the wall and apply pressure until a tight fit is achieved.

3. Screw on: Position the corner guard on the wall and attach it using the supplied screws.

4. Remove the protective plastic covering from the exposed surface of the corner guard.

3.04 CLEANING

A. At completion of the installation, clean surfaces in accordance with the IPC clean up and maintenance instructions.