

EnviroGT G2-1100 Handrail

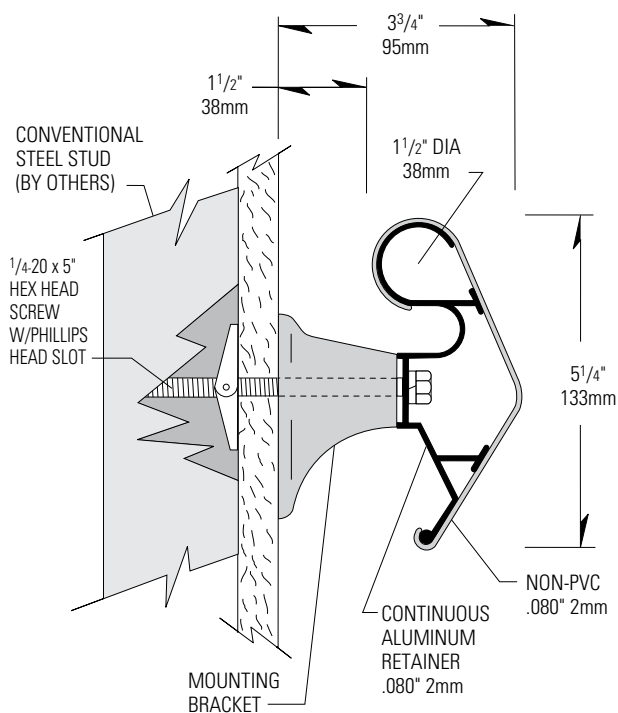

- ▶ Non-PVC cover is manufactured with G2 blend BioPolyPETG+, InPro's exclusive reformulated PETG made with a corn-based biopolymer and recycled content
- ▶ Protect walls with expanded coverage delivered by the angular design
- ▶ Meet safety codes with ADA and ANSI compliance
- ▶ Coordinate interiors with 100 standard colors and 11 Global Colours
- ▶ Minimize seams with standard 12' lengths
- ▶ Meets the most rigorous standards and criteria of chemical emissions as prescribed by the GREENGUARD Environmental Institute
- ▶ Has been tested and meets GREENGUARD Environmental Institute's and the state of California's requirements for low emitting products as tested by Air Quality Sciences
- ▶ Has been tested and meets the GREENGUARD Children & School chemical emissions levels



IPC.1127/REV.2

P.O. Box 406 · Muskego, Wisconsin 53150 USA
 inprocorp.com
 Nationwide 800.222.5556/Fax 888.715.8407
 International Sales 262.679.5521/Fax 262.679.5524



EnviroGT G2-1100 Handrail

Suggested Specifications

PART 1 – GENERAL

1.01 SUMMARY

- A. Non PVC Handrail systems for pedestrian safety and wall protection

1.02 SECTION INCLUDES

- A. G2-1100 Handrail Systems

1.03 REFERENCES

- A. American National Standards Institute (ANSI)
B. American Society for Testing and Materials (ASTM)
C. Americans with Disabilities Act (ADA)
D. National Fire Protection Association (NFPA)
E. Office of Statewide Health Planning and Development (OSHDP)
F. Society of Automotive Engineers (SAE)

1.04 SYSTEM DESCRIPTION

- A. Performance Requirements: Provide handrail systems that conform to the following requirements of regulatory agencies and the quality control of IPC Door and Wall Protection Systems, InPro Corporation.
1. Fire Performance Characteristics: Provide handrail conforming with the NFPA Class A fire rating. Surface burning characteristics, as determined by ASTM E-84, shall be flame spread of 25 or less and smoke development of 450 or less.
 2. Impact Strength: Provide profile materials that have been tested in accordance with the applicable provisions of ASTM D-256, Impact Resistance of Plastics.
 3. Chemical and Stain Resistance: Provide material that shows resistance to stain when tested in accordance with applicable provisions of ASTM D-543.
 4. Fungal and Bacterial Resistance: Provide material that does not support fungal or bacterial growth as tested in accordance with ASTM G-21 and ASTM G-22.
 5. GREENGUARD Certified: Provide GREENGUARD Certified profiles. Profiles shall meet the requirements of GREENGUARD Certification Standards for Low-Emitting Products and GREENGUARD Product Emission Standard For Children & Schools.
 6. Color Consistency: Provide components matched in accordance with SAE J-1545 - (Delta E) with a color difference no greater than 1.0 units using CIE Lab, CIE CMC, CIE LCh, Hunter Lab or similar color space scale systems.
 7. Code Compliance: Provide handrails that comply with all current ANSI and ADA requirements. In California, IPC Handrails are approved by OSHDP for use in Hospitals. OSHDP approval #OPA-0232.

1.05 SUBMITTALS

- A. Product Data: Manufacturer's printed product data for each product indicated in this section.
B. Detail Drawings: Mounting details with the appropriate fasteners for specific project substrates.
C. Samples: Verification samples of handrail, 8" (203mm) long, in full size profiles of each type and

color indicated.

- D. Manufacturer's Installation Instructions: Printed installation instructions for each handrail.

1.06 DELIVERY, STORAGE AND HANDLING

- A. Deliver materials in unopened factory packaging to the jobsite
B. Inspect materials at delivery to assure that specified products have been received.
C. Store in original packaging in a climate controlled location away from direct sunlight.

1.07 PROJECT CONDITIONS

- A. Environmental Requirements: Install products in an interior climate controlled environment.

1.08 WARRANTY

- A. Standard IPC Limited Lifetime Warranty against material and manufacturing defects.

PART 2 – PRODUCTS

2.01 MANUFACTURER

- A. Acceptable Manufacturer: IPC Interior Protection Products and Decorative Surfaces, InPro Corporation, PO Box 406, Muskego, WI 53150, USA; Telephone: 800.222.5556, Fax: 888.715.8407, www.inprocorp.com
B. Substitutions: Not permitted
C. Provide all handrails and wall protection from a single manufacturer.

2.02 LEED CRITERIA

- A. Provide handrail systems with components that have recycled content.
1. MR Credit 4.1, 10%(post-consumer + ½ pre-consumer), 1 credit
 2. MR Credit 4.2, 20%(post-consumer + ½ pre-consumer), 1 credit

2.03 MANUFACTURED UNITS

- A. Handrail Profile
1. G2-1100 Handrail, 5-1/4" (133mm) height x 1-1/2" (38mm) gripping diameter, extends 3-3/4" (95mm) from wall.

2.04 MATERIALS

- A. Reformulated PETG with Biopolymer Blend: Snap on cover of .080" (2mm) thickness shall be extruded from chemical and stain resistant PETG.
B. Aluminum: Continuous aluminum retainer of .080" (2mm) thickness shall be fabricated from 6063-T5 aluminum with a mill finish.

2.05 COMPONENTS

- A. Returns, inside corners, outside corners and brackets shall be made of injection molded thermoplastics.
B. Fasteners: All mounting system accessories appropriate for substrates indicated on the drawing shall be

provided.

2.06 FINISHES

- A. Handrail Covers: Handrail colors to be selected by the architect from the IPC finish selection.
B. Molded components: Inside corners, outside corners and brackets shall be of a color matching the handrails. Surface shall have a pebblette texture.

PART 3 – EXECUTION

3.01 EXAMINATION

- A. Examine areas and conditions in which the handrail system will be installed.
1. Complete all finishing operations, including painting, before beginning installation of handrail system materials.
 2. Wall surface shall be dry and free from dirt, grease and loose paint.

3.02 PREPARATION

- A. General: Prior to installation, clean substrate to remove dust, debris and loose particles.

3.03 INSTALLATION

- A. General: Locate handrail as indicated on approved detail drawings for the appropriate substrate and in compliance with the IPC installation instructions. Install handrail level and plumb at the height indicated on the drawings.
- B. Installation of G2-1100 Handrail:
1. Cut the aluminum retainer to the desired length, allowing 4-1/8" (105mm) for each return, 1/4" (6mm) for each outside corner.
 2. Attach returns, outside corners and brackets to the aluminum retainer. It is recommended that brackets are installed 4" (102mm) from the ends of a run. Spacing of brackets is recommended to be a maximum of 32" (813mm).
 3. Mount the aluminum retainer to the wall using the provided fasteners. Level and secure the aluminum retainer to the wall.
 4. Cut the vinyl cover to fit between the returns and/or outside corners. NOTE: Trim all factory edges square before installation. Position the vinyl cover on the aluminum retainer starting at the top of the retainer and pivoting the vinyl cover over the bottom of the retainer until it snaps into place.

3.04 CLEANING

- A. At completion of the installation, clean surfaces in accordance with the IPC clean-up and maintenance instructions.