

4000 Handrail with Spacer

Not available in the United States. Available in select International Markets.

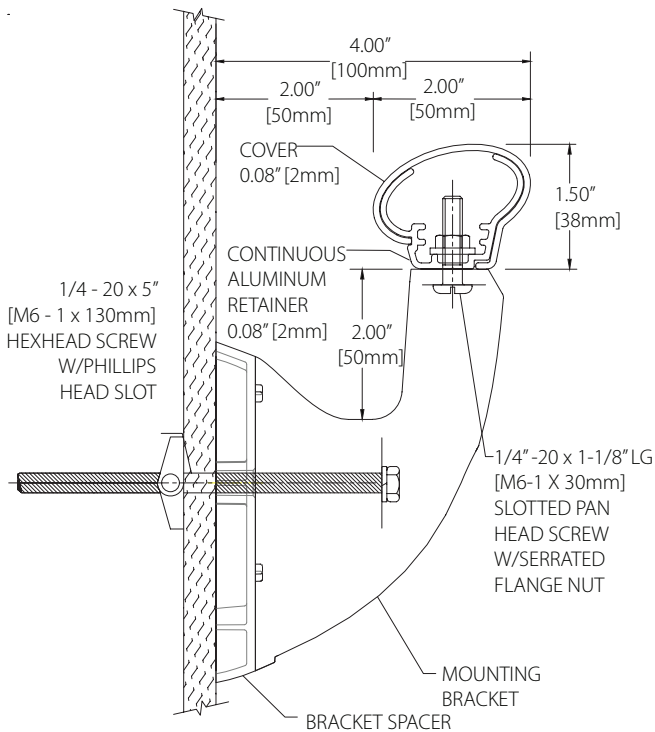

- 1-1/2" (38mm) x 2" (50mm) gripping surface
- Wall Clearance - 2" (50mm)
- Mounted on a sturdy .080" (2mm) thick, continuous aluminum retainer
- .080" (2mm) thick, scratch and stain resistant rigid vinyl cover
- Easy installation, clean-up and maintenance
- Meets ADA and ANSI criteria
- Manufactured in 12' (3.66m) standard lengths
- All mounting fasteners are included with each order
- Meets the most rigorous standards and criteria of chemical emissions as prescribed by the GREENGUARD Environmental Institute
- Has been tested and meets GREENGUARD Environmental Institute's and the state of California's requirements for low emitting products as tested by Air Quality Sciences
- Has been tested and meets the GREENGUARD Children & School chemical emissions levels



IPC.613/REV.1

4000 Handrail with Spacer

Suggested Specifications

PART 1 - GENERAL

1.01 SUMMARY

A. Handrail systems for pedestrian safety and wall protection

1.02 SECTION INCLUDES

A. 4000 Handrail System with Spacer

1.03 REFERENCES

- A. American National Standards Institute (ANSI)
- B. American Society for Testing and Materials (ASTM)
- C. Americans with Disabilities Act (ADA)
- D. National Building Code of Canada (NBC)
- E. National Fire Protection Association (NFPA)
- F. Society of Automotive Engineers (SAE)
- G. Underwriters Laboratory (UL)
- H. Underwriters Laboratory of Canada (ULC)
- I. Uniform Building Code (UBC)

1.04 QUALITY ASSURANCE

A. Performance Requirements: Provide handrail systems that conform to the following requirements of regulatory agencies and the quality control of IPC Door and Wall Protection Systems, InPro Corporation.

- 1. Fire Performance Characteristics: Provide handrail conforming with the NFPA Class A fire rating. Surface burning characteristics, as determined by ASTM E-84, shall be flame spread of 25 or less and smoke development of 450 or less.
- 2. Impact Strength: Provide profile materials that have been tested in accordance with the applicable provisions of ASTM D-256, Impact Resistance of Plastics.
- 3. Chemical and Stain Resistance: Provide material that shows resistance to stain when tested in accordance with applicable provisions of ASTM D-543.
- 4. Fungal and Bacterial Resistance: Provide material that does not support fungal or bacterial growth as tested in accordance with ASTM G-21 and ASTM G-22.
- 5. GREENGUARD Certified: Provide GREENGUARD Certified profiles. Profiles shall meet the requirements of GREENGUARD Certification Standards for Low-Emitting Products and GREENGUARD Product Emission Standard for Children & Schools.
- 6. Color Consistency: Provide components matched in accordance with SAE J-1545 - (Delta E) with a color difference no greater than 1.0 units using CIE Lab, CIE CMC, CIE LCh, Hunter Lab or similar color space scale systems.

1.05 SUBMITTALS

- A. Product Data: Manufacturer's printed product data for each type of handrail specified.
- B. Detail Drawings: Mounting details with the appropriate fasteners for specific project substrates.
- C. Samples: Verification samples of handrail, 8" (203mm) long, in full size profiles of each type and color indicated.
- D. Manufacturer's Installation Instruction: Printed installation instructions for each handrail.

1.06 DELIVERY, STORAGE AND HANDLING

- A. Deliver materials in unopened factory packaging to the jobsite
- B. Inspect materials at delivery to assure that specified products have been received.
- C. Store in original packaging in a climate controlled location away from direct sunlight.

1.07 PROJECT CONDITIONS

A. Environmental Requirements: Products must be installed in an interior climate controlled environment.

1.08 WARRANTY

A. Standard IPC Limited Lifetime Warranty against material and manufacturing defects.

PART 2 - PRODUCTS

2.01 MANUFACTURER

A. Acceptable Manufacturer:

IPC Door and Wall Protection Systems,
InPro Corporation,
PO Box 406 Muskego, WI 53150 USA;
Telephone: 800.222.5556, Fax: 888.715.8407,
www.inprocorp.com

B. Substitutions: Not permitted

C. Provide all handrails and wall protection from a single source.

2.02 MANUFACTURED UNITS

A. Handrail Profile

- 1. G2-4000 Handrail, 1-1/2" (38mm) x 2" (50mm) gripping surface, extends 4" (100mm) from wall.
Wall clearance - 2" (50mm).
Options: Curved handrail, specify radius. Minimum radius - 3 feet (.91m)

2.03 MATERIALS

- A. Vinyl: Snap-on covers of .080" (2mm) thickness shall be extruded from chemical and stain resistant polyvinyl chloride with the addition of impact modifiers. No plasticizers shall be added (plasticizers may aid in bacterial growth).
- B. Aluminum: Continuous aluminum retainer of .080" (2mm) thickness shall be fabricated from 6063-T5 aluminum with a mill finish.

2.04 COMPONENTS

- A. Returns, inside corners, outside corners, brackets and spacers shall be made of injection molded thermoplastics.
- B. Fasteners: All mounting system accessories appropriate for substrates indicated on the drawing shall be provided, unless installer supplied is indicated.

2.05 FINISHES

- A. Vinyl Covers: Handrail colors to be selected by the architect from the IPC finish selection. Surface shall have a pebblette texture.
- B. Molded components: Inside corners, outside corners, returns, brackets and spacers shall be of a color matching the handrails. Surface shall have a pebblette texture.

PART 3 - EXECUTION

3.01 EXAMINATION

- A. Examine areas and conditions in which the handrail systems will be installed.
- 1. Complete all finishing operations, including painting, before beginning installation of handrail system materials.
- 2. Wall surface shall be dry and free from dirt, grease and loose paint.

3.02 PREPARATION

A. General: Prior to installation, clean substrate to remove dust, debris and loose particles.

3.03 INSTALLATION

- A. General: Locate handrail as indicated on approved detail drawings for the appropriate substrate and in compliance with the IPC installation instructions. Install handrail level and plumb at the height indicated on the drawings.
- B. Installation of 4000 Handrail: Material must be stored, installed and used in environmentally controlled conditions
 - 1. Cut aluminum retainer to desired length, leaving allowance for returns, outside corners and inside corners.

2. Drill holes in centerline of aluminum retainer for brackets, returns and corners using 1/4" (7mm) drill bit.

Attach returns, inside corners and outside corners to retainer leaving a 1/16" (2mm) gap between returns/ corners and retainer to allow for adjustment.

2a. Plastic Bracket / Spacer - Attach bracket to retainer, then position 2" (50mm) bracket spacer onto the back of the bracket.

3. Position retainer against wall at desired height. Level and mark bracket holes on wall. Drill marked holes with 3/4" (20mm) drill bit for toggle bolts (drywall installation) or 1/2" (13mm) drill bit for lead anchor (concrete wall installation). Loosely attach mounting bolts to the bracket and spacer. Mount on wall, level retainer and tighten screws to secure. Snap cover over mounting base. NOTE: Attach 2" (50mm) return spacers before tightening screws and securing bracket to wall.

4. Cut cover to length between returns and/or corners. (Note: Trim factory edges square before installation). Position cover on retainer and adjust returns and/or corners for a tight fit. Starting at one end and work to the other end by pushing the cover onto the retainer until it is securely in place.

NOTE: Returns should be secured to the wall. Remove bottom plate and fasten installer supplied screws through hole located in the return. Reattach bottom plate.

3.04 CLEANING

A. At completion of the installation, clean surfaces in accordance with the IPC clean-up and maintenance instructions.