

31SS Stainless Steel Wall Guard

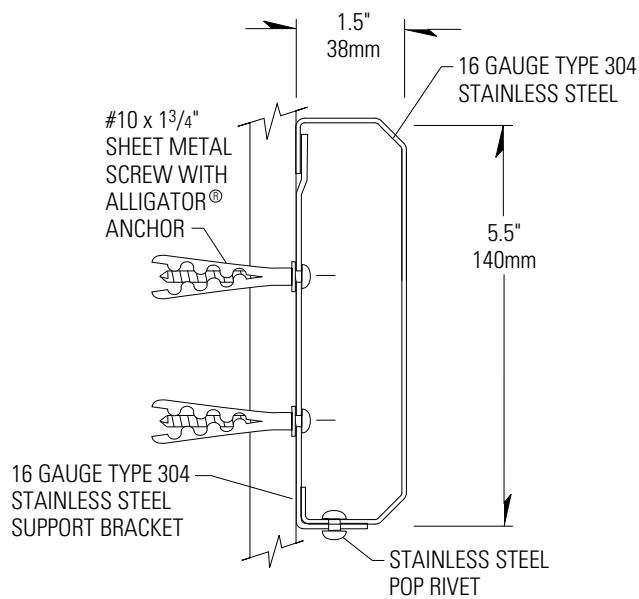

- Standard Type 304, 16 gauge stainless steel in a No. 4 satin finish
- Incorporates hidden fasteners and flat front profile for a sleek design
- Provides exceptional impact resistance in high abuse areas
- Made using 75% post-consumer recycled material – may contribute to Recycled Content credit in the LEED® Rating Systems

IPC.635/REV.1

31SS Stainless Steel Wall Guard

Suggested Specifications

PART 1 - GENERAL

1.01 SUMMARY

A. Stainless Steel Wall Guard system for wall protection

1.02 SECTION INCLUDES

A. 31SS Stainless Steel Wall Guard System, with Flat-front Profile.

1.03 SUBMITTALS

A. Product data for each type of wall guard specified.

B. Detail drawings indicating mounting details with the appropriate fasteners for specific project substrates.

C. Samples for verification purposes of wall guard, 6" (152mm) long, in full size profiles of each type and color indicated.

D. Cleaning and maintenance instructions for door and wall protection systems.

1.04 DELIVERY, STORAGE AND HANDLING

A. Deliver materials in unopened factory packaging to the jobsite and store in original packaging in a climate controlled location away from direct sunlight.

1.05 PROJECT CONDITIONS

A. Products must be installed in an interior climate controlled environment.

1.06 WARRANTY

A. Standard IPC Limited Lifetime Warranty against material and manufacturing defects.

PART 2 - PRODUCTS

2.01 MANUFACTURER

A. Acceptable Manufacturer:

IPC Door and Wall Protection Systems,
InPro Corporation PO Box 406 Muskego, WI 53150 USA
Telephone: 800.222.5556, Fax: 888.715.8407,
www.inprocorp.com

B. Substitutions: Not permitted

C. Provide all wall guards and wall protection from a single source.

2.02 MANUFACTURED UNITS

A. Wall Guards

1. Stainless Steel Wall Guard

Model Size 31SS, 5-1/2" (140mm) high x 1-1/2" (38mm) deep, with Flat-front Profile.

Type and Gauge - Type 304 16 gauge Stainless Fabricated to field verified dimensions

2.03 MATERIALS

A. Stainless Steel: Wall Guards shall be manufactured from Type 304, 16 gauge Stainless Steel

2.04 FINISHES

A. Stainless steel: No. 4 satin finish.

PART 3 - EXECUTION

3.01 EXAMINATION

A. Examine areas and conditions in which the wall guard systems will be installed.

1. Complete all finishing operations, including painting, before beginning installation of wall guards.

B. Wall surface shall be dry and free from dirt, grease and loose paint.

3.02 PREPARATION

A. General: Prior to installation, clean substrate to remove dust, debris and loose particles.

3.03 INSTALLATION

A. General: Locate the wall guard as indicated on the approved detail drawing for the appropriate substrate and in compliance with the IPC installation instructions. Install wall guard level and plumb at the height indicated on the drawings.

B. Installation of Stainless Steel Wall Guard

1. Determine the height to the top of the wall guard above the finished floor. Deduct 3/16" (5mm) and snap a chalk line at that height.

2. Use a retainer support as a template, position the top edge of the support against the chalk line, and mark the location of mounting holes on the wall. Supports are located 1/16" in from the outside of each end of the wall guard and spaced a maximum of 32" on center. When joining two sections of wall guard, use a retainer support on both sides of the joint. Tightly butt the two sections of wall guard together.

3. Drill 1/4" (6mm) holes at each mark. Position ALLIGATOR anchors into the holes on the wall and use #10 x 1-3/4" phillips pan head screw to attach each retainer support to the wall. Level and tighten the retainer supports to the wall.

4. Position the stainless steel wall guard on the retainer supports and transfer the hole locations on the bottom of each retainer support to the stainless steel wall guard. Remove stainless steel wall guard and drill a 9/64" hole at each mark.

5. Position the stainless steel wall guard on the retainer supports and secure the wall guard to the supports with 1/8" stainless steel pop rivets.

3.04 CLEANING

A. At completion of the installation, clean surfaces in accordance with the IPC clean up and maintenance instructions.