

# 30SS Stainless Steel Wall Guard

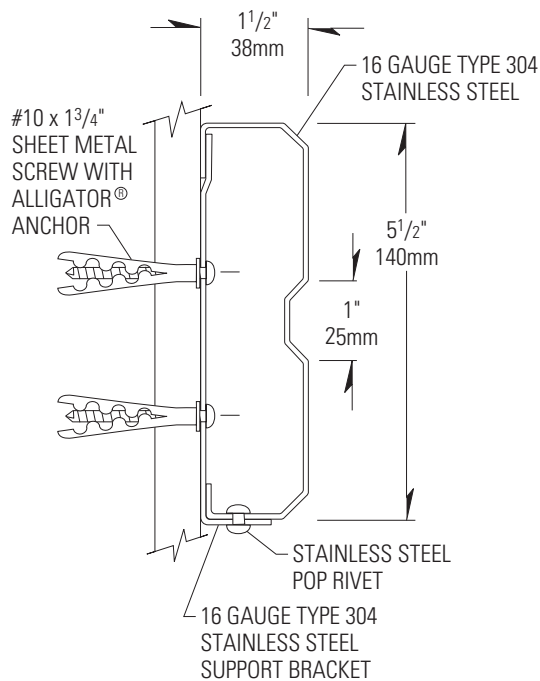

- ▶ 5 1/2" (140mm) of wall protection, extends 1 1/2" (38mm) from wall
- ▶ Standard Type 304, 16 gauge stainless steel
- ▶ Available in No. 4 satin finish
- ▶ Manufactured as pre-assembled lengths per field dimensions
- ▶ All mounting fasteners are included with each order

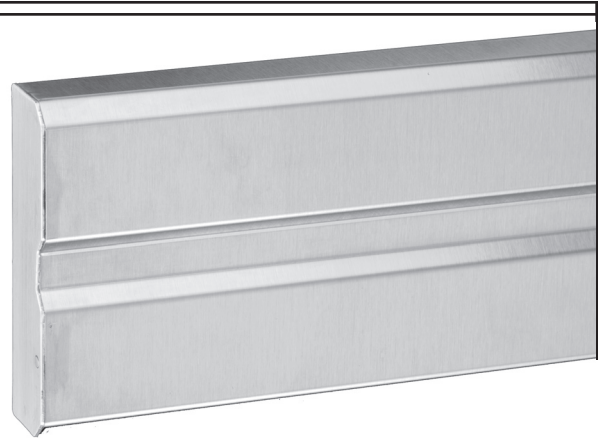

IPC.592/REV.3

P.O. Box 406 · Muskego, Wisconsin 53150 USA  
inprocorp.com  
Nationwide 800.222.5556/Fax 888.715.8407  
International Sales 262.679.5521/Fax 262.679.5524

**INPRO**  
**IPC** Interior Protection Products  
and Decorative Surfaces

# 30SS Stainless Steel Wall Guard

## Suggested Specifications

### PART 1 - GENERAL

#### 1.01 SUMMARY

A. Stainless Steel Wall Guard system for wall protection

#### 1.02 SECTION INCLUDES

A. 30SS Stainless Steel Wall Guard Systems

#### 1.03 SUBMITTALS

A. Product data for each type of wall guard specified.

B. Detail drawings indicating mounting details with the appropriate fasteners for specific project substrates.

C. Samples for verification purposes of wall guard, 6" (152mm) long, in full size profiles of each type and color indicated.

D. Cleaning and maintenance instructions for door and wall protection systems.

#### 1.04 DELIVERY, STORAGE AND HANDLING

A. Deliver materials in unopened factory packaging to the jobsite and store in original packaging in a climate controlled location away from direct sunlight.

#### 1.05 PROJECT CONDITIONS

A. Products must be installed in an interior climate controlled environment.

#### 1.06 WARRANTY

A. Standard IPC Limited Lifetime Warranty against material and manufacturing defects.

### PART 2 - PRODUCTS

#### 2.01 MANUFACTURER

A. Acceptable Manufacturer: IPC Door and Wall Protection Systems, InPro Corporation, PO Box 406 Muskego, WI 53150 USA; Telephone: 800.222.5556, Fax: 888.715.8407, [www.inprocorp.com](http://www.inprocorp.com)

B. Substitutions: Not permitted

C. Provide all wall guards and wall protection from a single source.

#### 2.02 MANUFACTURED UNITS

##### A. Wall Guards

1. Stainless Steel Wall Guard

##### Model Size

30SS, 5<sup>1</sup>/<sub>2</sub>" (140mm) h x 1<sup>1</sup>/<sub>2</sub>" (38mm) deep, Type and Gauge - Type 304 16 gauge Stainless Fabricated to field verified dimensions

#### 2.03 MATERIALS

A. Stainless Steel: Wall Guards shall be manufactured from Type 304, 16 gauge Stainless Steel

#### 2.04 FINISHES

A. Stainless steel: No. 4 satin finish.

### PART 3 - EXECUTION

#### 3.01 EXAMINATION

A. Examine areas and conditions in which the wall guard systems will be installed.

1. Complete all finishing operations, including painting, before beginning installation of wall guards.

B. Wall surface shall be dry and free from dirt, grease and loose paint.

#### 3.02 PREPARATION

A. General: Prior to installation, clean substrate to remove dust, debris and loose particles.

#### 3.03 INSTALLATION

A. General: Locate the wall guard as indicated on the approved detail drawing for the appropriate substrate and in compliance with the IPC installation instructions. Install wall guard level and plumb at the height indicated on the drawings.

B. Installation of Stainless Steel Wall Guard

1. Determine the height to the top of the wall guard above the finished floor. Deduct <sup>3</sup>/<sub>16</sub>" (5mm) and snap a chalk line at that height.

2. Use a retainer support as a template, position the top edge of the support against the chalk line, and mark the location of mounting holes on the wall. Supports are located <sup>1</sup>/<sub>16</sub>" in from the outside of each end of the wall guard and spaced a maximum of 32" on center. When joining two sections of wall guard, use a retainer support on both sides of the joint. Tightly butt the two sections of wall guard together.

3. Drill <sup>1</sup>/<sub>4</sub>" (6mm) holes at each mark. Position AL-LIGATOR anchors into the holes on the wall and use #10 x 1<sup>3</sup>/<sub>4</sub>" phillips pan head screw to attach each retainer support to the wall. Level and tighten the retainer supports to the wall.

4. Position the stainless steel wall guard on the retainer supports and transfer the hole locations on the bottom of each retainer support to the stainless steel wall guard. Remove stainless steel wall guard and drill a <sup>9</sup>/<sub>64</sub>" hole at each mark.

5. Position the stainless steel wall guard on the retainer supports and secure the wall guard to the supports with <sup>1</sup>/<sub>8</sub>" stainless steel pop rivets.

#### 3.04 CLEANING

A. At completion of the installation, clean surfaces in accordance with the IPC clean up and maintenance instructions.

