

Vinyl Cove Base

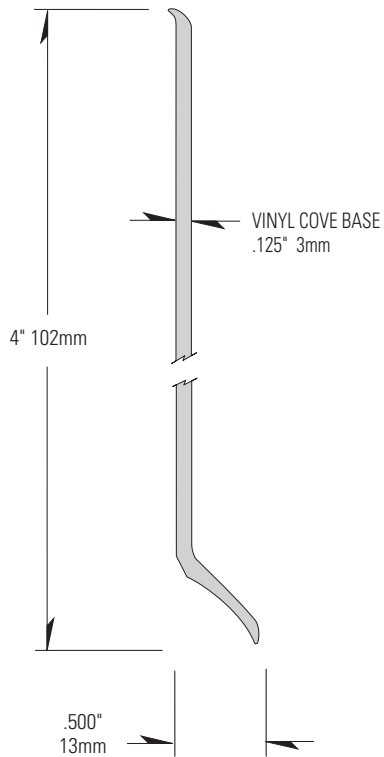

- ▶ Assures a snug fit along floor and wall
- ▶ Easy to clean & scuff resistant
- ▶ Available in 4" (2mm) height
- ▶ Stocked in 32 stocked colors, also available in 6" with minimum quantity requirements
- ▶ Available in 120' (36m) rolls

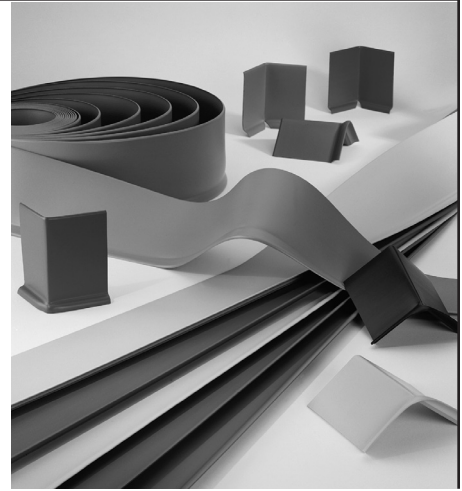

IPC.472/REV.7

P.O. Box 406 · Muskego, Wisconsin 53150 USA
inprocorp.com
Nationwide 800.222.5556/Fax 888.715.8407
International Sales 262.679.5521/Fax 262.679.5524

INPRO CORPORATION
Interior and Exterior Architectural Products

Vinyl Cove Base

Suggested Specifications

PART 1 - GENERAL

1.01 SUMMARY

- A. Cove base for wall protection

1.02 SECTION INCLUDES

- A. Vinyl Cove Base

1.03 REFERENCES

- A. American Society for Testing and Materials (ASTM)

1.04 SYSTEM DESCRIPTION

- A. Performance Requirements: Provide cove base that conform to the following requirements of regulatory agencies and the quality control of IPC Door and Wall Protection Systems, InPro Corporation.

1. Provide vinyl cove base complying with Federal Specification SS-W-40a, Type II.

2. Provide vinyl cove base complying with ASTM F-1861-98, Standard Specification for Resilient Wall Base.

1.05 SUBMITTALS

- A. Product Data: Manufacturer's printed product data for each type of cove base specified.

- B. Detail Drawings: Mounting details with the appropriate adhesives for specific project substrates.

- C. Samples: Verification samples of cove base, 5" (127mm) long, of each type and color indicated.

- D. Manufacturer's Installation Instruction: Printed installation instructions for cove base.

1.06 DELIVERY, STORAGE AND HANDLING

- A. Deliver materials in unopened factory packaging to the jobsite.

- B. Inspect materials at delivery to assure that specified product have been received.

- C. Store in original packaging in a climate controlled location away from direct sunlight.

1.07 PROJECT CONDITIONS

- A. Environmental Requirements: Products must be installed in an interior climate controlled environment.

1.08 WARRANTY

- A. Standard IPC Limited Lifetime Warranty against material and manufacturing defects.

PART 2 - PRODUCTS

2.01 MANUFACTURER

- A. Acceptable Manufacturer/Distributors: IPC Door and Wall Protection Systems, InPro Corporation, PO Box 406 Muskego, WI 53150 USA; Telephone: 800-222-5556, Fax: 888-715-8407, www.inprocorp.com

com

- B. Substitutions: Not permitted

- C. Provide all vinyl cove base and wall protection from a single source.

2.02 MANUFACTURED UNITS

- A. Vinyl Cove Base

1. CB4125VR-(color #)4" (102mm) x .125" (3mm) thick, roll

- B. Height: 4" (102mm)

Length: rolls: 120 feet.

Thickness: .125" (3mm)

Finish: Low gloss, satin (matte)

Style: Cove

Corners: Factory made outside corners or job made corners.

2.03 MATERIALS

- A. Vinyl: Cove base of .125" (3mm) thickness shall be manufactured from chemical and stain resistant flexible polyvinyl chloride.

2.04 FINISHES

1. Color of cove base to be selected by the architect from the IPC finish selection. Surface shall be low gloss, satin (matte).

PART 3 - EXECUTION

3.01 EXAMINATION

- A. Examine areas and conditions in which the cove base systems will be installed.

1. Complete all finishing operations, including painting, before beginning installation of cove base system materials.

- B. Wall surface shall be dry and free from dirt, grease and loose paint.

3.02 PREPARATION

- A. General: Prior to installation, clean substrate to remove dust, debris and loose particles.

3.03 INSTALLATION

- A. General: Locate the cove base as indicated on the approved detail drawing for the appropriate substrate and in compliance with the IPC installation instructions. Install cove base level and plumb at the height indicated on the drawings.

- B. Cove Base Installation

1. Wall surface must be thoroughly dry, smooth and free from dirt, wallpaper, vinyl wallcovering, grease, old adhesives and other extraneous material. DO NOT

apply directly over outside walls in direct contact with earth (such as unfurred basement walls) or over ceramic tile, metals or other impervious surfaces because poor adhesion may result. Maintain base, adhesive and room air at a uniform temperature of at least 70° F for 24 hours prior to, during and for 48 hours after installation. Rolled base should be unrolled and allowed to lie flat for 24 hours prior to installation to regain normal shape. Vinyl cove base MUST NOT be stretched.

2. Job made inside corners: Miter cut the base to form an inside corner. Check the fit, apply adhesive, position the base and roll it to secure the base to the wall. Bracing may be required until the adhesive sets.

3. Job made outside corners: Mark the location on the back of the base where the corner is to be formed. Lay base face down and cut a shallow groove, no deeper than 20% of the base thickness, over the height of the base where the corner is to be formed. Check the fit, apply adhesive and roll the corner to secure it. Bracing may be required until adhesive sets.

4. Spread adhesive to the back of the base using a triangular notched trowel or cove base adhesive gun. Trowel notches should be 3/32" deep by 3/32" wide with 3/32" flats. If applying adhesive with a gun use a 3-hole nozzle for 4" base and a 5-hole nozzle for 6" base. Apply adhesive at least 1/4" from the top of the base is using a trowel and 1" from the top if using a gun so adhesive does not seep out as base is rolled.

5. Bond base within 20 minutes of adhesive application. Roll thoroughly with hand roller immediately after applying base. If roller is unavailable, wipe the base with a soft cloth, firmly pressing the base against the wall. Base applied to curved or irregular surfaces may require bracing. If wall or floor is uneven, it may be necessary to trim edges before installing adjoining pieces of the base. Use a utility knife, cutting base from face to back.

6. Immediately remove excess adhesive from base or wall with water. Excess adhesive may leave a stain if not removed promptly.

3.04 CLEANING

- A. At completion of the installation, clean surfaces in accordance with the IPC clean-up and maintenance instructions.

