

# 3500MV Silhouette Handrail

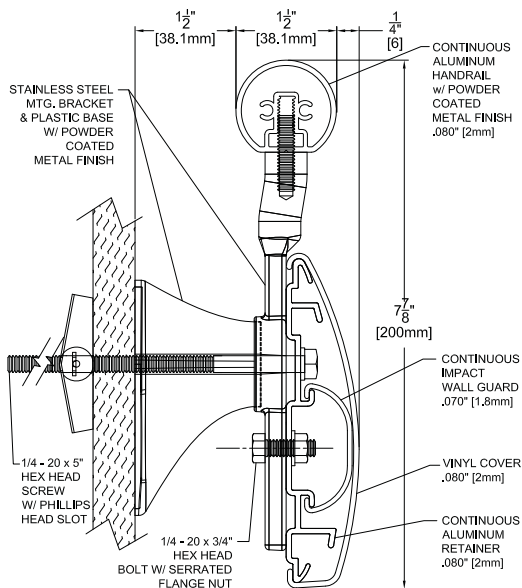

- 7-7/8" (200mm) height x 1-1/2" (38mm) gripping diameter, extends 3/4" (82mm) from the wall
- Handrail has an aluminum wall thickness of .080" (2mm)
- Handrail is available in 10 Metal Tone finish options
- Lower wall guard is mounted on a sturdy .080" (2mm) thick, continuous aluminum retainer
- Wall guard is covered with a scratch and stain resistant, .080" (2mm) thick, rigid vinyl cover
- Wall guard available in 100 standard colors and seven Woodland patterns
- .070" (1.8mm) continuous impact bumper
- Meets ADA and ANSI criteria
- Manufactured in 8' – 16' (2.44m – 4.88m) standard lengths
- All mounting fasteners are included with each order
- May qualify for LEED MR Credit 4.1 = 1 credit; MR Credit 4.2 = 1 credit

IPC.668/REV.2

# 3500MV Silhouette Handrail

## Suggested Specifications

### PART 1 GENERAL

#### 1.01 SUMMARY

A. Handrail systems for pedestrian safety and wall protection

#### 1.02 SECTIONS INCLUDES

A. 3500MV Silhouette Handrail System, aluminum handrail with integrated vinyl wall guard

#### 1.03 REFERENCES

- A. American National Standards Institute (ANSI)
- B. American Society for Testing and Materials (ASTM)
- C. American with Disabilities Act (ADA)
- D. Environmental Protection Agency (EPA)
- E. Kitchen Cabinets Manufacturers Association (KCMA)
- F. National Emission Standards for Hazardous Air Pollutants (NESHAP)
- G. National Fire Protection Association (NFPA)
- H. Society of Automotive Engineers (SAE)

#### 1.04 SYSTEM DESCRIPTION

A. Performance Requirements: Provide metal handrail systems with integrated wall guard that conform to the following requirements of regulatory agencies and the quality control of IPC Door and Wall Protection Systems, InPro Corporation.

1. Fire Performance Characteristics: Provide metal handrail components conforming with NFPA Class A fire rating. Surface burning characteristics, as determined by ASTM E-84, shall be flame spread of 0 and smoke development of 5.
2. Fire Performance Characteristics: Provide UL Classified vinyl handrail components conforming with NFPA Class A fire rating. Surface burning characteristics, as determined by UL-723 (ASTM E-84), shall be flame spread of 10 and smoke development of 350 - 450. Provide ULC (Canada) listed handrails conforming to the requirements of the National Building Code of Canada 2010, Subsection 3.1.13. Surface burning characteristics, as determined by CAN/ULCS102.2, shall be flame spread of 15 and smoke developed of 35.
3. Self Extinguishing: Provide handrails with a CC1 classification, as tested in accordance with the procedures specified in ASTM D-635-74, Standard Test Method for Rate of Burning and/or Extent and Time of Burning of Self-Supporting Plastics in a Horizontal Position, as referenced in UBC 52-4-1988.
4. Impact Strength: Provide rigid vinyl profile materials that have an Impact Strength of 30.2 ft-lbs/inch of thickness as tested in accordance with the procedures specified in ASTM D-256-90b, Impact Resistance of Plastics.
5. Chemical and Stain Resistance: Provide vinyl handrails profiles and powder coated metals that show resistance to stain when tested in accordance with applicable provisions of ASTM D-543.
6. Fungal and Bacterial Resistance: Provide powder coated metal components that does not support fungal or bacterial growth as tested in accordance with ASTM G-21 and ASTM G-22.
7. Fungal and Bacterial Resistance: Provide rigid vinyl that does not support fungal or bacterial growth as tested in accordance with ASTM G-21 and ASTM G-22.
8. Color Consistency: Provide components matched in accordance with SAE J-1545 - (Delta E) with a color difference no greater than 1.0 units using CIE Lab, CIE CMC, CIE LCh, Hunter Lab or similar color space scale systems.
9. Code Compliance: Provide handrails that comply with all current ANSI and ADA requirements.

#### 1.05 SUBMITTALS

A. Product Data: Manufacturer's printed product data for each product indicated in this section.

B. Detail Drawings: Mounting details with appropriate fasteners for specific project substrates.

C. Samples: Verification samples of handrail, 10" (254mm) long, in full size profiles with mounting brackets of each type indicated.

D. Manufacturer's Installation Instructions: Printed installation instructions for each handrail.

#### 1.06 DELIVERY, STORAGE AND HANDLING

A. Deliver materials in unopened factory packaging to the jobsite.

B. Inspect materials at delivery to assure that specified products have been received.

C. Store in original packaging in a climate controlled environment away from direct sunlight.

#### 1.07 WARRANTY

A. Standard IPC limited lifetime warranty against material and manufacturing defects.

### PART 2 PRODUCTS

#### 2.01 MANUFACTURERS

A. Acceptable Manufacturer: IPC Door and Wall Protection Systems, InPro Corporation, PO Box 406, Muskego, WI 53150 USA;

Telephone 800-543-1729, Fax: 888-715-8407,

Internet address: [www.inprocorp.com](http://www.inprocorp.com)

B. Substitutions: Not permitted

C. Provide all handrails and wall protection from a single manufacturer.

#### 2.02 LEED Criteria

A. Provide handrail systems with metal components that have recycled content.

1. MR CR4.1, 10% (post-consumer + 1/2 pre-consumer), 1 Credit

2. MR CR4.2, 20% (post-consumer + 1/2 pre-consumer), 1 Credit

#### 2.03 MANUFACTURED UNITS

A. Metal/Vinyl Handrail System

1. 3500MV Silhouette Handrail, 7-7/8" (200mm) height x 1-1/2" (38mm) gripping diameter, system extends 3-1/4" (83mm) from the wall. System includes 1-1/2" (38mm) diameter metal top rail and an integrated 5" (127mm) vinyl wall guard.

2. Options: Curved handrail, specify radius. Minimum radius - 3 feet (.91m)

#### 2.04 MATERIALS

A. Aluminum:

1. Continuous aluminum retainer of .080" (2mm) thickness shall be fabricated from 6063-T5 aluminum with a mill finish.

2. Continuous aluminum rail of .080" (2mm) thickness shall be fabricated from 6063-T5 aluminum with a powder coat finish.

B. Stainless Steel:

1. Stainless steel brackets shall be #4 satin finish.

C. Vinyl:

1. Molded Vinyl: Returns and corners shall be made of injection mold, chemical and stain resistant polyvinyl chloride.

2. Extruded Vinyl: Snap-on wall guard vinyl covers of .080" (2mm) thickness shall be extruded from chemical and stain resistant polyvinyl chloride with the addition of impact modifier. Inner snap-on vinyl impact bumper of .070" (1.8mm) thickness shall be extruded from chemical and stain resistant polyvinyl chloride with the addition of impact modifier. No plasticizers shall be

added (plasticizers may aid in bacterial growth).

#### 2.05 COMPONENTS

A. Handrail returns, outside corners and inside corners shall be stainless steel and a finish/color to match handrails.

B. Molded wall guard returns, corners and brackets shall be made of injection molded thermoplastic and a color matching the wall guard.

C. Stainless steel brackets shall be fabricated from cast stainless steel with a brushed finish or a solid color powder coat metal tone finish.

D. Fasteners: All mounting systems accessories appropriate for substrates indicated on the drawings shall be provided.

#### 2.06 FINISHES

A. Handrail Color: Color of the handrail to be selected by the architect from the InPro Corporation metal tone color palette.

B. Vinyl Covers: Color of the vinyl cover to be selected, by the architect, from the IPC finish selection. Surface shall have a pebblette texture.

C. Stainless Steel Brackets

1. Color of the stainless steel bracket to be selected by the architect from the solid color metal tone color palette.

2. Color of stainless steel shall be #4 satin finish stainless steel.

D. Molded Bracket Components: Molded bracket components shall be of a color matching the wall guard. Surface shall have a pebblette texture.

### PART 3 EXECUTION

#### 3.01 INSTALLERS

A. Installer should be familiar with the installation of fine finished wood products.

#### 3.02 EXAMINATION

A. Examine areas and conditions in which handrail will be installed.

1. Complete all finishing operations, including painting, before beginning installation of handrail system materials.

2. Wall surface shall be dry and free from dirt, grease and loose paint.

#### 3.03 PREPARATION

A. General: Prior to installation, clean substrate to remove dust, debris and loose particles.

#### 3.04 INSTALLATION

A. General: Locate the handrail as indicated on the approved detail drawing for the appropriate substrate and in compliance with the IPC installation instructions. Install handrail level and plumb at the height indicated on the drawings.

#### 3.05 CLEANING

A. At completion of the installation, clean surfaces in accordance with the IPC clean-up and maintenance instructions.