

3500MM Silhouette Handrail

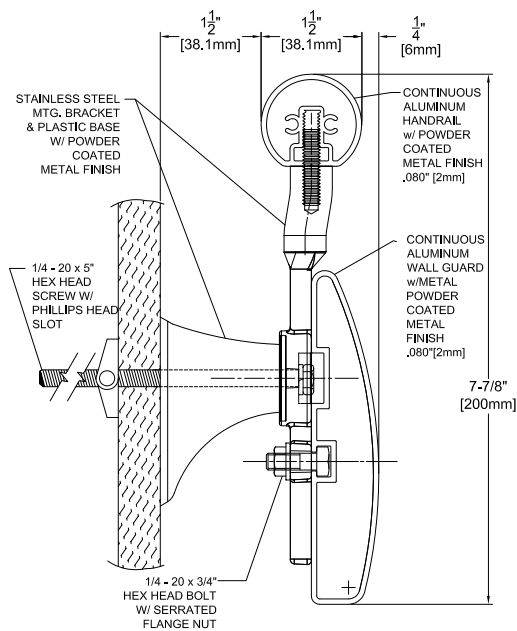

- ▶ 77/8" (200mm) height x 1½" (38mm) gripping diameter, extends 3¼" (82mm) from the wall
- ▶ Handrail and wall guard have an aluminum wall thickness of .080" (2mm)
- ▶ Mix or match handrail and wall guard with 10 Metal Tone finish options
- ▶ Meets ADA and ANSI criteria
- ▶ Manufactured in 8' - 16' (2.44m - 4.88m) standard lengths
- ▶ All mounting fasteners are included with each order
- ▶ May qualify for LEED MR Credit 4.1 = 1 credit; MR Credit 4.2 = 1 credit



IPC.666/REV.1

P.O. Box 406 · Muskego, Wisconsin 53150 USA
 inprocorp.com
 Nationwide 800.222.5556/Fax 888.715.8407
 International Sales 262.679.5521/Fax 262.679.5524

INPRO
IPC Interior Protection Products
 and Decorative Surfaces

3500MM Silhouette Handrail

Suggested Specifications

PART 1 GENERAL

3500MM Silhouette Handrail
Suggested Specifications

PART 1 GENERAL

1.01 SUMMARY

A. Handrail systems for pedestrian safety and wall protection

1.02 SECTIONS INCLUDES

A. 3500MM Silhouette Handrail System, aluminum handrail with integrated aluminum wall guard

1.03 REFERENCES

- A. American National Standards Institute (ANSI)
- B. American Society for Testing and Materials (ASTM)
- C. American with Disabilities Act (ADA)
- D. National Fire Protection Association (NFPA)

1.04 SYSTEM DESCRIPTION

A. Performance Requirements: Provide metal handrail systems with integrated wall guard that conform to the following requirements of regulatory agencies and the quality control of IPC Door and Wall Protection Systems, InPro Corporation.

1. Fire Performance Characteristics: Provide metal handrail components conforming with NFPA Class A fire rating. Surface burning characteristics, as determined by ASTM E-84, shall be flame spread of 0 and smoke development of 5.

2. Fungal and Bacterial Resistance: Provide powder coated metal components that does not support fungal or bacterial growth as tested in accordance with ASTM G-21 and ASTM G-22.

3. Chemical and Stain Resistance: Provide powder coat materials that show resistance to stain when tested in accordance with applicable provisions of ASTM D-543.

4. Code Compliance: Provide handrails that comply with all current ANSI and ADA requirements.

1.05 SUBMITTALS

A. Product Data: Manufacturer's printed product data for each product indicated in this section.

B. Detail Drawings: Mounting details with appropriate fasteners for specific project substrates.

C. Samples: Verification samples of handrail, 10" (254mm) long, in full size profiles with mounting brackets of each type indicated.

D. Manufacturer's Installation Instructions: Printed installation instructions for each handrail.

1.06 DELIVERY, STORAGE AND HANDLING

A. Deliver materials in unopened factory packaging to the jobsite.

B. Inspect materials at delivery to assure that specified products have been received.

C. Store in original packaging in a climate controlled environment away from direct sunlight.

1.07 WARRANTY

A. Standard IPC limited lifetime warranty against material and manufacturing defects.

PART 2 PRODUCTS

2.01 MANUFACTURERS

A. Acceptable Manufacturer: IPC Door and Wall Protection Systems, InPro Corporation, PO Box 406, Muskego, WI 53150 USA;

Telephone 800-543-1729, Fax: 888-715-8407,

Internet address: www.inprocorp.com

B. Substitutions: Not permitted

C. Provide all handrails and wall protection from a single manufacturer.

2.02 LEED CRITERIA

A. Provide handrail systems with metal components that have recycled content.

1. MR CR4.1, 10% (post-consumer + 1/2 pre-consumer), 1 Credit

2. MR CR4.2, 20% (post-consumer + 1/2 pre-consumer), 1 Credit

2.03 MANUFACTURED UNITS

A. Metal/Metal Handrail System

1. 3500MM Silhouette Handrail, 7-7/8" (200mm) height x 1-1/2" (38mm) gripping diameter, system extends 3-1/4" (83mm) from the wall. System includes 1-1/2" (38mm) diameter metal top handrail and an integrated 5" (127mm) metal wall guard.

2.04 MATERIALS

A. Aluminum:

1. Continuous aluminum rail of .080" (2mm) thickness shall be fabricated from 6063-T5 aluminum.

2. Cast wall guard returns and corners shall be fabricated from aluminum.

B. Stainless Steel:

1. Stainless steel brackets, returns and corners shall be type 304, stainless steel.

C. Vinyl:

1. Molded components shall be made of polyvinyl chloride.

2.05 COMPONENTS

A. Handrail returns and corners shall be type 304, stainless steel and a finish/color to match handrails.

B. Wall guard returns and outside corners shall be fabricated of aluminum in a finish/color to match the wall guard.

C. Stainless steel brackets shall be #4 satin finish.

D. Molded bracket components shall be fabricated from injection molded polyvinyl chloride.

E. Fasteners: All mounting systems accessories appropriate for substrates indicated on the drawings shall be provided.

2.06 FINISHES

A. Handrail Color: Color of the handrail to be selected by the architect from the InPro Corporation metal tone color palette.

B. Wall Guard Color: Color of the wall guard to be selected by the architect from the InPro Corporation metal tone color palette.

C. Stainless Steel Brackets

1. Color of the stainless steel bracket to be selected by the architect from the solid color metal tone color

palette.

2. Color of stainless steel brackets shall be #4 satin finish stainless steel.

D. Molded Bracket Components: Molded bracket components shall be of a color matching the wall guard. Surface shall have a pebblette texture.

PART 3 EXECUTION

3.01 INSTALLERS

A. Installer should be familiar with the installation of fine finished wood products.

3.02 EXAMINATION

A. Examine areas and conditions in which handrail will be installed.

1. Complete all finishing operations, including painting, before beginning installation of handrail system materials.

2. Wall surface shall be dry and free from dirt, grease and loose paint.

3.03 PREPARATION

A. General: Prior to installation, clean substrate to remove dust, debris and loose particles.

3.04 INSTALLATION

A. General: Locate the handrail as indicated on the approved detail drawing for the appropriate substrate and in compliance with the IPC installation instructions. Install handrail level and plumb at the height indicated on the drawings.

3.05 CLEANING

A. At completion of the installation, clean surfaces in accordance with the IPC clean-up and maintenance instructions.

