

3500WM Silhouette Handrail

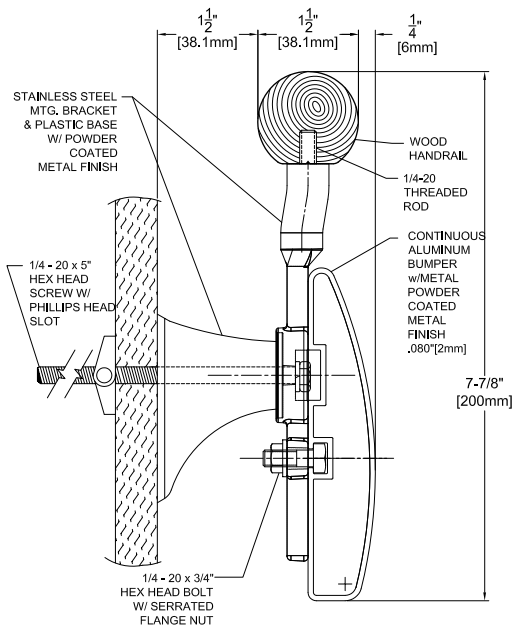

- ▶ 77/8" (200mm) height x 1½" (38mm) gripping diameter, extends 3¼" (82mm) from the wall
- ▶ Wood handrail available in red oak or maple in seven stain colors
- ▶ Lower wall guard has an aluminum wall thickness of .080" (2mm)
- ▶ Lower wall guard is available in 10 Metal Tone finish options
- ▶ Meets ADA and ANSI criteria
- ▶ Manufactured in 8' - 16' (2.44m - 4.88m) standard lengths
- ▶ All mounting fasteners are included with each order
- ▶ May qualify for LEED MR Credit 4.1 = 1 credit; MR Credit 4.2 = 1 credit



IPC.655/REV.2

P.O. Box 406 · Muskego, Wisconsin 53150 USA
 inprocorp.com
 Nationwide 800.222.5556/Fax 888.715.8407
 International Sales 262.679.5521/Fax 262.679.5524

INPRO CORPORATION
 Interior and Exterior Architectural Products

3500WM Silhouette Handrail

Suggested Specifications

PART 1 GENERAL

1.01 SUMMARY

A. Handrail systems for pedestrian safety and wall protection

1.02 SECTIONS INCLUDES

A. 3500WM Silhouette Handrail System, wood handrail with integrated aluminum wall guard.

1.03 REFERENCES

- A. American National Standards Institute (ANSI)
- B. American Society for Testing and Materials (ASTM)
- C. American with Disabilities Act (ADA)
- D. Environmental Protection Agency (EPA)
- E. Kitchen Cabinets Manufacturers Association (KCMA)
- F. National Emission Standards for Hazardous Air Pollutants (NESHAP)
- G. Society of Automotive Engineers (SAE)

1.04 SYSTEM DESCRIPTION

A. Performance Requirements: Provide wood handrail systems with integrated wall guard that conform to the following requirements of regulatory agencies and the quality control of IPC Door and Wall Protection Systems, InPro Corporation.

1. Fire Performance Characteristics: Provide metal wall guard components conforming with NFPA Class A fire rating. Surface burning characteristics, as determined by ASTM E-84, shall be flame spread of 0 and smoke development of 5.
2. Fungal and Bacterial Resistance: Provide powder coated metal components that do not support fungal or bacterial growth as tested in accordance with ASTM G-21 and ASTM G-22.
3. Cold, heat and chemical resistance: Provide wood handrail with a finish that complies with the applicable provisions of ANSI/KCMA A161.1- 1990 for cold check, heat and chemical resistance.
4. Environmental compliance: Provide wood handrail and with a finish that does not off gas or emit any VOC, after a full cure, as tested in accordance to the EPA, NESHAP, Method 24, 40CFR, Volume 60, Appendix A.
5. Chemical and Stain Resistance: Provide powder coat materials that show resistance to stain when tested in accordance with applicable provisions of ASTM D-543.
6. Code Compliance: Provide handrails that comply with all current ANSI and ADA requirements.

1.05 SUBMITTALS

- A. Product Data: Manufacturer's printed product data for each product indicated in this section.
- B. Detail Drawings: Mounting details with appropriate fasteners for specific project substrates.
- C. Samples: Verification samples of handrail, 10" (254mm) long, in full size profiles with mounting brackets of each type indicated.

D. Manufacturer's Installation Instructions: Printed installation instructions for each handrail.

1.06 DELIVERY, STORAGE AND HANDLING

- A. Deliver materials in unopened factory packaging to the jobsite.
- B. Inspect materials at delivery to assure that specified products have been received.
- C. Store in original packaging in a climate controlled environment away from direct sunlight.

1.07 WARRANTY

A. Standard IPC limited lifetime warranty against material and manufacturing defects.

PART 2 PRODUCTS

2.01 MANUFACTURERS

- A. Acceptable Manufacturer: IPC Door and Wall Protection Systems, InPro Corporation, PO Box 406, Muskego, WI 53150 USA; Telephone 800-543-1729, Fax: 888-715-8407, Internet address: www.inprocorp.com
- B. Substitutions: Not permitted
- C. Provide all handrails and wall protection from a single manufacturer.

2.02 MANUFACTURED UNITS

- A. Wood/Metal Handrail System
- 1. 3500WM Silhouette Handrail, 7 7/8" (200mm) height x 1-1/2" (38mm) gripping diameter, system extends 3-3/4" (83mm) from the wall. System includes a 1 1/2" diameter wood handrail and an integrated 5" (127mm) aluminum wall guard.

2.03 MATERIALS

- A. Wood: Shall be FAS grade, kiln dried, solid maple or red oak with moisture content of 5-9%.
- B. Forest Stewardship Council (FSC) Wood: Shall be kiln dried solid FSC Ash.
- C. Aluminum
- 1. Extruded Aluminum: Continuous aluminum wall guard with a minimum wall thickness of .080" (2mm) shall be fabricated from 6063-T5 aluminum with a powder coat finish.
- 2. Cast Aluminum: Wall guard returns and corners shall be fabricated from die cast aluminum.
- D. Stainless Steel: handrail brackets, returns and corners shall be manufactured of type 304 stainless steel.
- E. Vinyl: Molded components shall be made of polyvinyl chloride.

2.04 COMPONENTS

- A. Handrail returns and corners
- 1. Solid wood and a finish to match handrails.
- 2. Stainless steel with a brushed #4 satin finish.
- B. Wall guard returns and corners shall be fabricated from cast aluminum with a finish to match the wall guard.
- C. Stainless steel bracket shall be fabricated from cast

stainless steel with a brushed finish or a solid color powder coat metal tone finish.

D. Molded bracket components shall be fabricated from injection molded polyvinyl chloride.

E. Fasteners: All mounting systems accessories appropriate for substrates indicated on the drawings shall be provided.

2.05 FINISHES

- A. Wood Stain: Color of the handrail to be selected, by the architect, from the IPC stain selection.
- B. Wood Finish: Handrail shall be finished with low-VOC water based UV finish.
- C. Wall Guard Color: Color of the wall guard to be a color selected by the architect from the InPro metal tone color selection.
- C. Stainless Steel Brackets
- 1. Color of the stainless steel bracket to be selected by the architect from the solid color metal tone color palette.
- 2. Color of stainless steel brackets shall be #4 satin finish stainless steel.
- D. Molded bracket components shall be a color matching the wall guard. Surface shall have a pebblette texture.

PART 3 EXECUTION

3.01 INSTALLERS

A. Installer should be familiar with the installation of fine finished wood products.

3.02 EXAMINATION

A. Examine areas and conditions in which handrail will be installed.

1. Complete all finishing operations, including painting, before beginning installation of handrail system materials.

2. Wall surface shall be dry and free from dirt, grease and loose paint.

3.03 PREPARATION

A. General: Prior to installation, clean substrate to remove dust, debris and loose particles.

3.04 INSTALLATION

A. General: Locate the handrail as indicated on the approved detail drawing for the appropriate substrate and in compliance with the IPC installation instructions. Install handrail level and plumb at the height indicated on the drawings.

3.05 CLEANING

A. At completion of the installation, clean surfaces in accordance with the IPC clean-up and maintenance instructions.

