

3000/3000FW/3055 Handrails



3000



3000FW



Patent #5,743,064

3055

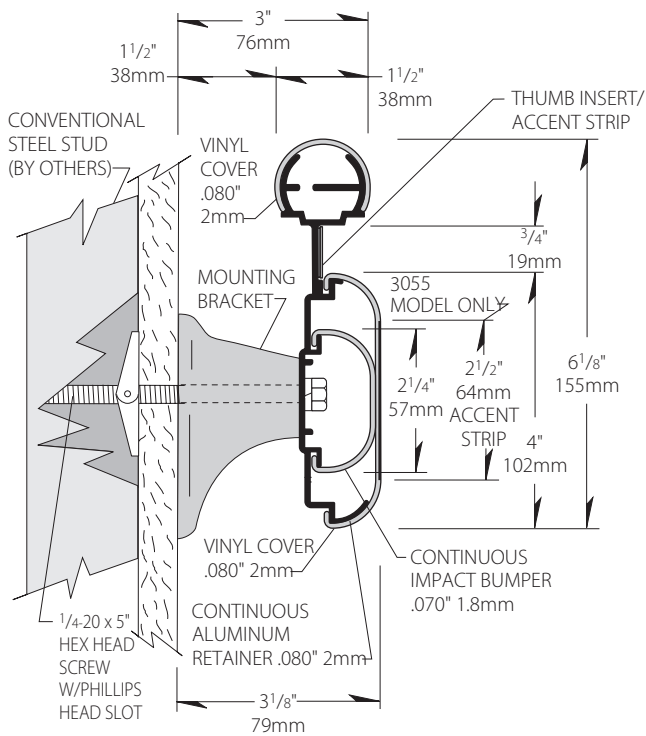

- 6-1/8" (155mm) height x 1-1/2" (38mm) gripping diameter, extends 3" (76mm) from the wall
- Mounted on a sturdy .080" (2mm) thick, continuous aluminum retainer
- .080" (2mm) thick, scratch and stain resistant rigid vinyl cover
- Decorative thumb insert for color coordination
- Easy installation, clean-up and maintenance
- Meets ADA and ANSI criteria
- Manufactured in 12' standard lengths
- All mounting fasteners are included with each order
- 3055 Model - 2-1/2" (64mm) high accent strip on lower portion of handrail available in 100 standard colors, as well as custom colors
- 3000FW Model - Manufactured with woodland pattern full wrap. 3000FW includes black reveals for returns and corners
- Meets the most rigorous standards and criteria of chemical emissions as prescribed by the GREENGUARD Environmental Institute
- Has been tested and meets GREENGUARD Environmental Institute's and the state of California's requirements for low emitting products as tested by Air Quality Sciences
- Has been tested and meets the GREENGUARD Children & School chemical emissions levels



IPC.547/REV.10

3000/3000FW/3055 Handrails

Suggested Specifications

PART 1 GENERAL

1.01 SUMMARY

A. Handrail systems for pedestrian safety and wall protection

1.02 SECTIONS INCLUDES

A. 3000/3000FW Handrail System.

1.03 REFERENCES

- A. American National Standards Institute (ANSI)
- B. American Society for Testing and Materials (ASTM)
- C. American with Disabilities Act (ADA)
- D. National Building Code of Canada (NBC)
- E. National Fire Protection Association (NFPA)
- F. Society of Automotive Engineers (SAE)
- G. Underwriters Laboratory (UL)
- H. Underwriters Laboratory of Canada (ULC)

I. Uniform Building Code (UBC)

1.04 SYSTEM DESCRIPTION

A. Performance Requirements: Provide handrail system with integrated impact bumpers that conform to the following requirements of regulatory agencies and the quality control of IPC Door and Wall Protection Systems, InPro Corporation.

1. Fire Performance Characteristics: Provide UL Classified impact bumper conforming with NFPA Class A fire rating. Surface burning characteristics, as determined by UL-723 (ASTM E-84), shall be flame spread of 10 and smoke development of 350 - 450. Provide ULC (Canada) listed impact bumper conforming to the requirements of the National Building Code of Canada 2010, Subsection 3.1.13. Surface burning characteristics, as determined by CAN/ULC-S102.2, shall be flame spread of 15 and smoke developed of 35.
 2. Self Extinguishing: Provide impact bumpers with a CC1 classification, as tested in accordance with the procedures specified in ASTM D-635-74, Standard Test Method for Rate of Burning and/or Extent and Time of Burning of Self-Supporting Plastics in a Horizontal Position, as referenced in UBC 52-4-1988.
 3. Impact Strength: Provide rigid vinyl materials that have an impact strength of 30.2 ft-lbs/inch of thickness as tested in accordance with the procedures specified in ASTM D-256-90b, Impact Resistance of Plastics.
 4. Chemical and Stain Resistance: Provide impact bumpers that show resistance to stain when tested in accordance with applicable provisions of ASTM D-543.
 5. GREENGUARD Certified: Provide GREENGUARD Certified material. Profiles shall meet the requirements of GREENGUARD Certification Standards for Low-Emitting Products and GREENGUARD Product Emission Standard for Children & Schools.
 6. Fungal and Bacterial Resistance: Provide rigid vinyl that does not support fungal or bacterial growth as tested in accordance with ASTM G-21 and ASTM G-22.
 7. Color Consistency: Provide thermoplastic components matched in accordance with SAE J-1545 - (Delta E) with a color difference no greater than 1.0 units using CIE Lab, CIE CMC, CIE LCh, Hunter Lab or similar color space scale systems.
 8. Code Compliance: Provide handrails that comply with all current ANSI and ADA requirements. In California, IPC handrails are approved by OSHPD for use in hospitals. OSHPD approved #R-0232.
- #### 1.05 SUBMITTALS
- A. Product Data: Manufacturer's printed product data for each product indicated in this section.
 - B. Detail Drawings: Mounting details with appropriate fasteners for specific project substrates.
 - C. Loaner Samples: Verification samples of handrail, 15" (381mm) long, in full size profiles with one return and one mounting bracket of each type and color

indicated. Return samples to IPC after review.

D. Manufacturer's Installation Instructions: Printed installation instructions for each handrail.

1.06 DELIVERY, STORAGE AND HANDLING

- A. Deliver materials in unopened factory packaging to the jobsite.
- B. Inspect materials at delivery to assure that specified products have been received.
- C. Store in original packaging in a climate controlled environment away from direct sunlight.

1.07 WARRANTY

A. Standard IPC limited lifetime warranty against material and manufacturing defects.

PART 2 PRODUCTS

2.01 MANUFACTURERS

A. Acceptable Manufacturer: IPC Door and Wall Protection Systems, InPro Corporation, PO Box 406, Muskego, WI 53150 USA; Telephone 800.222.5556, Fax: 888.715.8407, Internet address: www.inprocorp.com

B. Substitutions: Not permitted

C. Provide all handrails and wall protection from a single manufacturer.

2.02 MANUFACTURED UNITS

A. Handrail

1. 3000 Handrail, 6¹/₈" (155mm) height x 1¹/₂" (38mm) gripping diameter, system extends 3¹/₈" (79mm) from the wall. Integrated vinyl cover, 4" (101mm) high. Inner impact bumper, 2¹/₄" (57mm) high. Thumb insert accent strip, 3³/₄" (19mm) high.
2. 3055 Handrail, 6¹/₈" (155mm) height x 1¹/₂" (38mm) gripping diameter, system extends 3-1¹/₈" (79mm) from the wall. Integrated vinyl cover, 4" (101mm) high with 2¹/₂" (64mm) accent strip. Inner impact bumper, 2¹/₂" (57mm) high. Thumb insert accent strip, 3³/₄" (19mm) high.
3. 3000FW Handrail, 6¹/₈" (155mm) height x 1¹/₂" (38mm) gripping diameter, system extends 3¹/₈" (79mm) from the wall. Integrated vinyl cover, 4" (102mm) high. Inner impact bumper, 2¹/₄" (57mm) high. Thumb insert accent strip, 3³/₄" (19mm) high. Handrail and/or wall guard shall have a full wrap woodgrain pattern. Returns and corners include reveals.

2.03 MATERIALS

- A. Vinyl: Snap-on vinyl covers of .080" (2mm) thickness shall be extruded from chemical and stain resistant polyvinyl chloride with the addition of impact modifier. Inner snap-on vinyl impact bumper of .070" (1.8mm) thickness shall be extruded from chemical and stain resistant polyvinyl chloride with the addition of impact modifier. No plasticizers shall be added (plasticizers may aid in bacterial growth). Accent strip when used shall be of polyvinyl chloride.
- B. Aluminum: Continuous aluminum retainer of .080" (2mm) thickness shall be fabricated from 6063-T5 aluminum, with a mill finish.

2.04 COMPONENTS

- A. Molded returns, inside corners, outside corners and brackets shall be made of injection molded thermoplastic.
- B. Molded reveals shall have a smooth finish and shall be black.
- C. Fasteners: All mounting systems accessories appropriate for substrates indicated on the drawings shall be provided.

2.05 FINISHES

- A. Vinyl Covers: Color of the vinyl cover to be selected, by the architect, from the IPC finish selection. Surface shall have a pebblette texture.
- B. Inner Impact Bumper: Color of the inner impact

bumper to be black.

- C. Molded components: Returns, inside corners and outside corners shall be of a color/finish matching the handrails. Surface shall have a pebblette texture.
- D. Molded Bracket: Shall be a solid color to match or compliment the handrails. Surface shall have a pebblette texture.
- E. Thumb insert accent strip: Color of the accent strip to be selected, by the architect, from the IPC finish selection.

PART 3 EXECUTION

3.01 INSTALLERS

A. Installer should be familiar with the installation of fine finished wood products.

3.02 EXAMINATION

A. Examine areas and conditions in which handrail will be installed.

1. Complete all finishing operations, including painting, before beginning installation of handrail system materials.

2. Wall surface shall be dry and free from dirt, grease and loose paint.

3.03 PREPARATION

A. General: Prior to installation, clean substrate to remove dust, debris and loose particles.

3.04 INSTALLATION

A. General: Locate the handrail as indicated on the approved detail drawing for the appropriate substrate and in compliance with the IPC installation instructions. Install handrail level and plumb at the height indicated on the drawings.

3.05 CLEANING

A. At completion of the installation, clean surfaces in accordance with the IPC clean-up and maintenance instructions.