

Heavy Duty Rubber Corner Guard

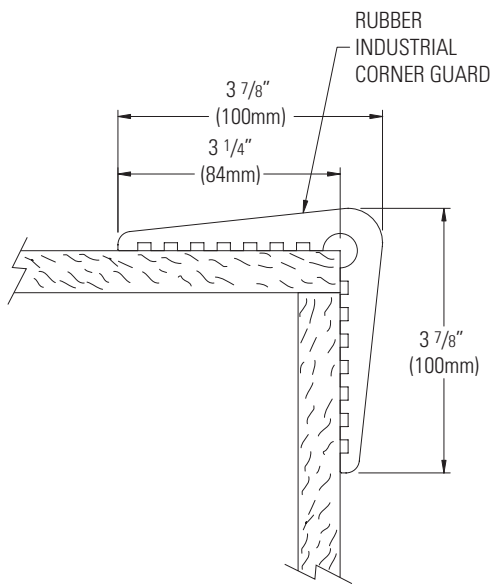

- ▶ Provides 4" (100mm) wing with 90° corner protection
- ▶ Manufactured in 10' (3.05m) standard heights
- ▶ Suitable for interior and exterior applications
- ▶ Available in black



IPC.370/Rev.3

P.O. Box 406 · Muskego, Wisconsin 53150 USA
inprocorp.com
Nationwide 800.222.5556/Fax 888.715.8407
International Sales 262.679.5521/Fax 262.679.5524

INPRO
IPC Interior Protection Products
and Decorative Surfaces

Heavy Duty Rubber Corner Guard

Suggested Specifications

PART 1 – GENERAL

1.01 SUMMARY

- A. Rubber corner guards for wall protection

1.02 SECTION INCLUDES

- A. Heavy Duty Rubber Corner Guards

1.03 REFERENCES

- A. British Standard (BS)
B. International Rubber Hardness Degree (IRHD)

1.04 SYSTEM DESCRIPTION

- A. Performance Requirements: Provide heavy duty rubber corner guards that conform to the following requirements of regulatory agencies and the quality control of IPC Door and Wall Protection Systems, InPro Corporation.
1. Tensile: Provide heavy duty rubber corner guards with a maximum tensile of 14 mn/m², when tested in accordance with BS 903 A2.
 2. Elongation: Provide heavy duty rubber corner guards with a 300% minimum elongation when tested in accordance with BS 903 A2.
 3. Hardness: Provide heavy duty rubber corner guards with a hardness of 65-75 IRHD when tested in accordance with BS 903 A26.
 4. Compression Set: Provide heavy duty rubber corner guards with a maximum compression set of 30% when tested in accordance with BS 903 A6A for 22 hours at 70°C.
 5. Tear Resistance: Provide heavy duty rubber corner guards with a minimum tear resistance of 40N/mn when tested in accordance with BS 903 A3,m method C.
- #### 1.05 SUBMITTALS
- A. Product Data: Manufacturer's printed product data for each type of wall protection specified.
B. Detail Drawings:
C. Samples: Verification samples of wall protection, in full size profiles of each type and color indicated.
D. Manufacturer's Installation Instruction: Printed installation instructions for heavy duty rubber corner protection.

1.06 DELIVERY, STORAGE AND HANDLING

- A. Deliver materials in unopened factory packaging to the jobsite
B. Inspect materials at delivery to assure that specified products have been received.
C. Store in original packaging in a climate controlled location away from direct sunlight.

1.07 WARRANTY

- A. Standard IPC Limited Lifetime Warranty against material and manufacturing.

PART 2 – PRODUCTS

2.01 MANUFACTURER

- A. Acceptable Manufacturer/Distributor:
IPC Door and Wall Protection Systems, InPro Corporation, PO Box 406 Muskego, WI 53150 USA; Telephone: 800.222.5556, Fax: 888.715.8407, www.inprocorp.com
B. Substitutions: Not permitted
C. Provide all heavy duty rubber corner guards from a single source.

2.02 MANUFACTURED UNITS

- A. Corner Guard Profile
1. Heavy Duty Rubber Corner Guard Model number, dimensions DW-CGR4-10, 4"(100mm) x 4"(100mm) x 9.843'(3m)height

2.03 MATERIALS

- A. Heavy duty rubber corner guard shall be extruded from UV resistant and ageing resistant styrene butadiene/natural rubber blend (SBR).

2.04 FINISHES

- A. Heavy Duty Rubber Corner Guards: Colors of the corner guard shall be black in a uniform quality and free from foreign substances.

PART 3 – EXECUTION

3.01 EXAMINATION

- A. Examine areas and conditions in which the wall protection will be installed.
1. Complete all finishing operations, including

painting, before beginning installation of wall protection materials.

- B. Wall surface shall be dry and free from dirt, grease and loose paint.

3.02 PREPARATION

- A. General: Prior to installation, clean substrate to remove dust, debris and loose particles.

3.03 INSTALLATION

- A. General: Locate corner guard as indicated on the approved detail drawing for the appropriate substrate, and in compliance with the IPC installation instructions. Install corner guard level and plumb at the height indicated on the drawings.
- B. Installation of Heavy Duty Rubber Corner Guards:
1. Cut the corner guard to the required length. Drill ³/₁₆" holes on each wing of the corner guard. Holes should be 1" from the end and space approximately 24" apart. Stagger holes on the other wing starting with the holes 2" from the end. There are 12 fasteners per 9.843'length. #12 stainless steel screws (Installer supplied) with flat washers are recommended.
 2. Use the corner guard as a template, and transfer the hole locations to the wall. Drill holes for the fasteners at each mark on the wall.
 3. Mount the corner guard on the wall using the fasteners and flat washers. Tighten the fasteners to secure the corner guard.

3.04 CLEANING

- A. At completion of the installation, clean surfaces in accordance with the IPC clean up and maintenance instructions.

