

Smooth Surface Tape-On Corner Guards

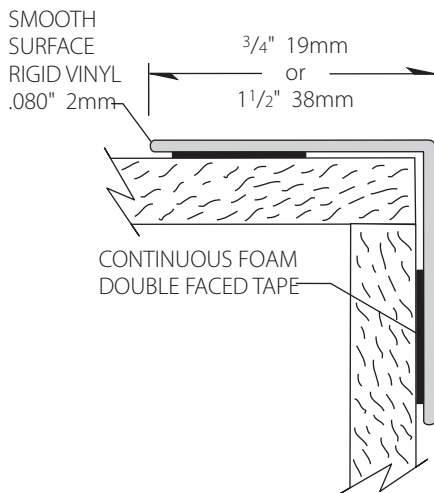

- .080" (2mm) thick rigid vinyl
- Standard with factory applied double faced foam tape. Available without tape to be applied with optional field applied heavy duty adhesive.
- Manufactured in 3' (.91m), 4' (1.22m), 8' (2.44m), 9' (2.74m) and 12' (3.66m) standard heights, custom heights available
- Meets the most rigorous standards and criteria of chemical emissions as prescribed by the GREENGUARD Environmental Institute
- Has been tested and meets GREENGUARD Environmental Institute's and the state of California's requirements for low emitting products as tested by Air Quality Sciences
- Has been tested and meets the GREENGUARD Children & School chemical emissions levels



IPC.434/REV.9

Smooth Surface Tape-On Corner Guards

Suggested Specifications

PART 1 - GENERAL

1.01 SUMMARY

A. Corner guard system for wall protection

1.02 SECTION INCLUDES

A. Smooth Tape-on Corner Guard

1.03 REFERENCES

A. American Society for Testing and Materials (ASTM)

B. National Building Code of Canada (NBC)

C. National Fire Protection Association (NFPA)

D. Society of Automotive Engineers (SAE)

E. Underwriters Laboratory (UL)

F. Underwriters Laboratory of Canada (ULC)

G. Uniform Building Code (UBC)

1.04 SYSTEM DESCRIPTION

A. Performance Requirements: Provide corner guard systems that conform to the following requirements of regulatory agencies and the quality control of IPC Door and Wall Protection Systems, InPro Corporation.

1. Fire Performance Characteristics: Provide UL Classified corner guards conforming with NFPA Class A fire rating. Surface burning characteristics, as determined by UL-723 (ASTM E-84), shall be flame spread of 10 and smoke development of 350 - 450. Provide ULC (Canada) listed corner guards conforming to the requirements of the National Building Code of Canada 2010, Subsection 3.1.13. Surface burning characteristics, as determined by CAN/ULC-S102.2, shall be flame spread of 15 and smoke developed of 35.

2. Self Extinguishing: Provide corner guards with a CC1 classification, as tested in accordance with the procedures specified in ASTM D-635-74, Standard Test Method for Rate of Burning and/or Extent and Time of Burning of Self-Supporting Plastics in a Horizontal Position, as referenced in UBC 52-4-1988.

3. Impact Strength: Provide rigid vinyl profile materials that have an Impact Strength of 30.2 ft-lbs/inch of thickness as tested in accordance with the procedures specified in ASTM D-256-90b, Impact Resistance of Plastics.

4. Chemical and Stain Resistance: Provide corner guards that show resistance to stain when tested in accordance with applicable provisions of ASTM D-543.

5. GREENGUARD Certified: Provide GREENGUARD Certified material. Profiles shall meet the requirements of GREENGUARD Certification Standards for Low-Emitting Products and GREENGUARD Product Emission Standard for Children & Schools.

6. Fungal and Bacterial Resistance: Provide rigid vinyl that does not support fungal or bacterial growth as tested in accordance with ASTM G-21 and ASTM G-22.

7. Color Consistency: Provide components matched in accordance with SAE J-1545 - (Delta E) with a color difference no greater than 1.0 units using CIE Lab, CIE CMC, CIE LCh, Hunter Lab or similar color space scale systems.

1.05 SUBMITTALS

A. Product Data: Manufacturer's printed product data for each type of corner guard specified.

B. Detail Drawings: Mounting details with the appropriate adhesives for specific project substrates.

C. Samples: Verification samples of corner guard, 8" (203mm) long, in full size profiles of each type and

color indicated.

D. Manufacturer's Installation Instruction: Printed installation instructions for each corner guard.

1.06 DELIVERY, STORAGE AND HANDLING

A. Deliver materials in unopened factory packaging to the jobsite

B. Inspect materials at delivery to assure that specified products have been received.

C. Store in original packaging in a climate controlled location away from direct sunlight.

1.07 PROTECTIVE CONDITIONS

A. Environmental Requirements: Products must be installed in an interior climate controlled environment.

1.08 WARRANTY

A. Standard IPC Limited Lifetime Warranty against material and manufacturing defects.

PART 2 - PRODUCTS

2.01 MANUFACTURER

A. Acceptable Manufacturer: IPC Door and Wall Protection Systems, InPro Corporation, PO Box 406 Muskego, WI 53150 USA; Telephone: 800.222.5556, Fax: 888.715.8407, www.inprocorp.com

B. Substitutions: Not permitted

C. Provide all corner guards and wall protection from a single source.

2.02 MANUFACTURED UNITS

A. Corner Guard Profile

1. Smooth Tape-on Corner Guards

3/4" (19mm) x 3/4" (19mm) 90 degree

1 1/2" (38mm) x 1 1/2" (38mm) 90 degree

Standard heights: 3' (91m), 4' (1.22m), 8' (2.44m),

9' (2.74m) and 12' (3.66m). Custom heights available

2.03 MATERIALS

A. Vinyl: Corner guard of .080" (2mm) thickness shall be extruded from chemical and stain resistant polyvinyl chloride with the addition of impact modifiers. No plasticizers shall be added (plasticizers may aid in bacterial growth).

2.04 COMPONENTS

A. Attachments

1. Tape: Factory applied double-faced foam tape.

2. Adhesive: Field applied heavy-duty adhesive.

2.05 FINISHES

A. Vinyl: Colors of the corner guard to be selected by the architect from the IPC finish selection. Surface shall be smooth.

B. Vinyl: Patterns of the corner guard to be selected by the architect from the IPC finish selection. Surface shall be smooth.

PART 3 - EXECUTION

3.01 EXAMINATION

A. Examine areas and conditions in which the corner guard systems will be installed.

1. Complete all finishing operations, including painting, before beginning installation of corner guard system materials.

B. Wall surface shall be dry and free from dirt, grease and loose paint.

3.02 PREPARATION

A. General: Prior to installation, clean substrate to remove

dust, debris and loose particles.

3.03 INSTALLATION

A. General: Locate the corner guard as indicated on the approved detail drawing for the appropriate substrate and in compliance with the IPC installation instructions. Install corner guard level and plumb at the height indicated on the drawings.

B. Installation of Smooth Tape-on Corner Guards:

1. Allow the corner guards to reach room temperature before installing. The wall surface that the corner guards are to be applied must be dry and free of dirt, dust, oil, loose paint wax and grease.

Note: When adhering to textured or difficult surfaces, such as stucco, glazed block or wall paper, use IPC# 535 Heavy Duty Adhesive to adhere corner guards. Corner Guards should be ordered without tape.

2. Installation with factory applied foam tape: Peel the paper release backing from the tape-on corner guard. Starting at the bottom, position the corner guard on the wall. Continue making contact between the corner guard and the corner over the entire height of the corner guard.

3. Installation with Heavy Duty Adhesive: Cut a small opening in the spout of the adhesive cartridge. Apply a continuous bead of adhesive on each wing of the corner guard. Starting at the bottom, position the corner guard on the wall. Continue making contact between the corner guard and the corner over the entire height of the corner guard.

4. Apply firm pressure to the entire surface of the corner guard to ensure a firm bond. An extension roller will aid this step.

Note: Smooth Tape-on Corner Guards are available without factory applied double-faced foam tape. When ordering, denote with suffix "n" after the model number.

3.04 CLEANING

A. At completion of the installation, clean surfaces in accordance with the IPC clean-up and maintenance instructions.