

150D End Wall Protector

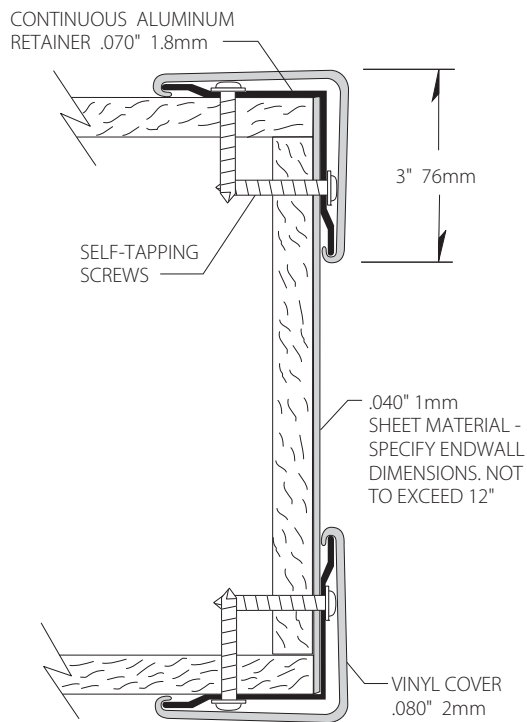

- 3" (76mm) wing
- Provides superior end wall protection with two surface mount corner guards
- Mounted on a sturdy .070" (1.8mm) pre-slotted continuous aluminum retainer
- .080" (2mm) thick scratch and stain resistant rigid vinyl cover, .040" (1mm) sheet material
- Manufactured in 3' (.91m), 4' (1.22m), 8' (2.44m), 9' (2.74m) and 12' (3.66m) standard heights, custom heights available
- All mounting fasteners are included with each order
- Available in 100 standard colors and Woodland patterns
- Meets the most rigorous standards and criteria of chemical emissions as prescribed by the GREENGUARD Environmental Institute
- Has been tested and meets GREENGUARD Environmental Institute's and the state of California's requirements for low emitting products as tested by Air Quality Sciences
- Has been tested and meets the GREENGUARD Children & School chemical emissions levels



IPC.400/REV.8

S80 W18766 Apollo Drive • Muskego, Wisconsin 53150 USA
 inprocorp.com
 Nationwide 800.222.5556 / Fax 888.715.8407
 International Sales 262.679.5521 / Fax 262.679.5524

INPRO 
IPC DOOR and WALL
 PROTECTION SYSTEMS

150D End Wall Protector

Suggested Specifications

PART 1 - GENERAL

1.01 SUMMARY

A. End wall protector system for wall protection

1.02 SECTION INCLUDES

A. 150D Surface Mount End Wall Protector System

1.03 REFERENCES

A. American Society for Testing and Materials (ASTM)

B. National Building Code of Canada (NBC)

C. National Fire Protection Association (NFPA)

D. Society of Automotive Engineers (SAE)

E. Underwriters Laboratory (UL)

F. Underwriters Laboratory of Canada (ULC)

G. Uniform Building Code (UBC)

1.04 SYSTEM DESCRIPTION

A. Performance Requirements: Provide end wall protectors that conform to the following requirements of regulatory agencies and the quality control of IPC Door and Wall Protection Systems™, InPro Corporation.

1. Fire Performance Characteristics: Provide UL Classified end wall protectors conforming with NFPA Class A fire rating. Surface burning characteristics, as determined by UL-723 (ASTM E-84), shall be flame spread of 10 and smoke development of 350 - 450. Provide ULC (Canada) listed end wall protectors conforming to the requirements of the National Building Code of Canada 2010, Subsection 3.1.13. Surface burning characteristics, as determined by CAN/ULC-S102.2, shall be flame spread of 15 and smoke developed of 35.

2. Fire Performance Characteristics: Provide UL Classified Sheet, Rigid Vinyl Sheet conforming with the NFPA Class A fire rating. Surface burning characteristics, as determined by UL-723, for Sheet installed with 3M Fastbond 30, shall be flame spread of 10 and smoke development of 95-140 for .040" (1mm) thick material or flame spread of 15 and smoke development of 300 for .060" (1.5mm) thick material. For Sheet installed with Super Tek Products, XT-2000 adhesive, shall be flame spread of 20 and smoke development of 60-105 for .040" (1mm) thick material or flame spread of 20 and smoke development of 250 for .060" (1.5mm) thick material. Provide ULC (Canada) listed Sheet conforming to the requirements of the National building Code of Canada 2010, Subsection 3.1.13. Surface burning characteristics, as determined by CAN/ULC-S102.2, shall be flame spread of 15 and smoke developed of 30.

3. Self Extinguishing: Provide end wall protectors with a CC1 classification, as tested in accordance with the procedures specified in ASTM D-635-74, Standard Test Method for Rate of Burning and/or Extent and Time of Burning of Self-Supporting Plastics in a Horizontal Position, as referenced in UBC 52-4-1988.

4. Impact Strength: Provide rigid vinyl profile materials that have an Impact Strength of 30.2 ft-lbs/inch of thickness as tested in accordance with the procedures specified in ASTM D-256-90b, Impact Resistance of Plastics.

5. Impact Strength: Provide rigid vinyl sheet materials that have an Impact Strength of 30.4 ft-lbs/inch of thickness as tested in accordance with the procedures specified in ASTM D-256-90b, Impact Resistance of Plastics.

6. GREENGUARD Certified: Provide GREENGUARD Certified material. Profiles shall meet the requirements of GREENGUARD Certification Standards for Low-Emitting Products and GREENGUARD Product Emission Standard for Children & Schools.

7. Chemical and Stain Resistance: Provide end wall protectors that show resistance to stain when tested in

accordance with applicable provisions of ASTM D-543.

8. Fungal and Bacterial Resistance: Provide Rigid vinyl that does not support fungal or bacterial growth as tested in accordance with ASTM G-21 and ASTM G-22.

9. Color Consistency: Provide components matched in accordance with SAE J-1545 - (Delta E) with a color difference no greater than 1.0 units using CIE Lab, CIE CMC, CIE LCh, Hunter Lab or similar color space scale systems.

1.05 SUBMITTALS

A. Product Data: Manufacturer's printed product data for each type of end wall protector specified.

B. Detail Drawings: Mounting details with the appropriate adhesives for specific project substrates.

C. Samples: Verification samples of end wall protector, 8" (203mm) long, in full size profiles of each type and color indicated.

D. Manufacturer's Installation Instruction: Printed installation instructions for each end wall protector.

1.06 DELIVERY, STORAGE AND HANDLING

A. Deliver materials in unopened factory packaging to the jobsite

B. Inspect materials at delivery to assure that specified products have been received.

C. Store in original packaging in a climate controlled location away from direct sunlight.

1.07 PROJECT CONDITIONS

A. Environmental Requirements: Products must be installed in an interior climate controlled environment.

1.08 WARRANTY

A. Standard IPC Limited Lifetime Warranty against material and manufacturing defects.

PART 2 - PRODUCTS

2.01 MANUFACTURER

A. Acceptable Manufacturer: IPC Door and Wall Protection Systems™, InPro Corporation, PO Box 406 Muskego, WI 53150 USA; Telephone: 800.222.5556, Fax: 888.715.8407, www.inprocorp.com

B. Substitutions: Not permitted

C. Provide all end wall protectors and wall protection from a single source.

2.02 MANUFACTURED UNITS

A. End Wall Protectors System

1. 150D Series End Wall Protector Profile
3" (76mm) x 3" (76mm) 90 degree
4' (1.22m), 8' (2.44m), 9' (2.74m) and 12' (3.66m) standard heights
Custom heights available

2.03 MATERIALS

A. Vinyl: Snap on cover of .080" (2mm) thickness shall be extruded from chemical and stain resistant polyvinyl chloride with the addition of impact modifiers. No plasticizers shall be added (plasticizers may aid in bacterial growth).

B. Aluminum: Continuous aluminum retainer of .070" (1.8mm) thickness shall be fabricated from 6063-T5 aluminum, with a mill finish.

2.04 COMPONENTS

A. Top caps and bottom caps shall be made of injection molded thermoplastics.

B. Fasteners: All mounting system accessories appropriate for substrates indicated on the drawings shall be provided.

2.05 FINISHES

A. Vinyl Covers: Colors of the corner guard to be selected

by the architect from the IPC finish selection. Surface shall have a pebble texture.

B. Molded Components: Top caps and bottom caps shall be of a color matching the corner guards. Surface shall have a pebble texture.

PART 3 - EXECUTION

3.01 EXAMINATION

A. Examine areas and conditions where end wall protector will be installed.

1. Complete all finishing operations, including painting, before beginning installation of end wall protector system materials.

B. Wall surface shall be dry and free from dirt, grease and loose paint.

3.02 PREPARATION

A. General: Prior to installation, clean substrate to remove dust and debris.

3.03 INSTALLATION

A. General: Locate the end wall protector as indicated on the approved detail drawing for the appropriate substrate and in compliance with the IPC installation instructions. Install end wall protector level and plumb at the height indicated.

B. Installation of the 150D End Wall Protectors:

1. Adhere sheet material to the wall with factory applied adhesive backing or recommended IPC adhesive Fastbond 30 Contact Cement or XT-2000 Adhesive.

2. Position the aluminum retainer against the wall, allowing 5/16" (8mm) from the bottom of the aluminum to the top of the cove base or baseboard for the bottom cap.

3. Secure the aluminum to the wall using 1 1/4" phillips round head, self-tapping screws if mounting on drywall. Use 6 screws per 4' (1.22m) length, 10 screws per 8' (2.44m) length, or 12 screws per 9' (2.74m) length. The aluminum retainer is pre-slotted to aid in the installation. Used the slotted tabs on the top and bottom cap to transfer marks onto the retainer. Holes should be staggered 1/4" from each wing.

4. Attach the top and bottom caps to the aluminum retainer using two, 1 1/4" phillips flat head, self-tapping screws per cap if mounting on drywall. The mounting tabs for the top and bottom caps overlap the aluminum.

5. Position the vinyl cover on the aluminum retainer to check the fit. Adjust the top cap on the aluminum retainer to obtain a tight fit with the vinyl cover. Starting at the top, push the vinyl cover over the aluminum, pressing over the entire length until the vinyl snaps securely into place. Attach the second corner guard in the same manner.

3.04 CLEANING

A. At completion of the installation, clean surfaces in accordance with the IPC clean-up and maintenance instructions.