

SUPERIOR METAL PRODUCTS COMPANY, INC.

Walkway Cover Systems for Commercial, Industrial and Educational Facilities

10 73 00/SUP
BuyLine 6843



Entrance Canopy
Tyler, TX



Gardendale Medical Complex
Gardendale, AL



Southern Research Institute
Birmingham, AL



Plantside III
Louisville, KY



Navy Federal Credit Union
Pensacola, FL



The Chef's Academy
Indianapolis, IN



Ticket Booth Cover
Tuscaloosa, AL



Liberty County High School
Liberty County, GA



Aluminum Bus Shelter
Birmingham, AL

2010

Engineered Aluminum Canopies and Walkway Covers

Visit us at: www.SuperiorMetalProducts.com

116 Citation Court
Birmingham, AL 35209-6307
p. 877.445.1200
f. 205.945.5694

SUPERIOR METAL PRODUCTS COMPANY, INC.

email: canopysales@superiormetalproducts.com



**Bluffton Middle School
Bluffton, SC**

SUPERIOR PRODUCTS

1.01 DESCRIPTION OF WORK

Extent of canopies required is shown on the drawings. Included herein, but not limited to, are decking, fascia/gutter, columns, anchors, supports, and flashing.

1.02 MEASUREMENTS

Verify all measurements shown on drawings by taking field measurements to insure proper fit and attachment of all component parts.

1.03 SUBMITTALS

Provide manufacture shop drawings, including fabrication and installation details.

1.04 COORDINATION

Provide necessary anchors, blockouts, flashing and other items required to be built in ample time to avoid delays to the job.

1.05 DELIVERY & STORAGE

Deliver and store all items in protected area. Keep free of any damage. Replace any damaged items or parts at no cost to the Owner.

1.06 DESIGN PARAMETERS

Live load of canopies shall be no less than 20 p.s.f. Canopies shall comply in all respects with the International Code Council requirements for Floor, Wall and Roof systems.

1.07 ACCEPTABLE MANUFACTURER

Subject to compliance with requirements herein, provide product manufactured by Superior Metal Products Company, Inc., Birmingham, Alabama.

1.08 PRODUCTS AND MATERIALS

Consult Superior Metal Products' Architect Manual and design staff for detailed specifications of materials and products.

1.09 INSTALLATION

Canopies shall be installed according to approved plans and shop drawings and the entire structure shall be erected straight true and plumb in accordance with standard construction procedures. All joints and connections shall be tight and clean, and all surfaces of work left in a clean condition.

SUPERIOR QUALITY

Superior Metal Products Company, Inc. manufactures a complete line of rollformed and extruded canopies and walkway covers. From the smallest door canopy to the largest walkway cover, all materials are fabricated in the company's Birmingham, AL facility and undergo constant inspection and quality control. Innovative mechanical assembly procedures allow economical shipping to all points serviced by common carrier freight lines. Extruded systems are available in both painted and anodized finishes to harmonize with the widest range of architectural designs. Rollformed components are manufactured from only the highest quality, pre-tested and approved by independent registered structural engineers and are in compliance with the requirements of the International Code Council. Detailed shop drawings bearing the seal of a Registered Engineer are provided when required, and specification, design, and installation assistance is never more than a phone call away. Visit the company's web site at www.superiormetalproducts.com.



**U.S. Post Office
Prattville, AL**



**Westlawn Middle School
Tuscaloosa, AL**

CONFIGURATIONS

STANDARD

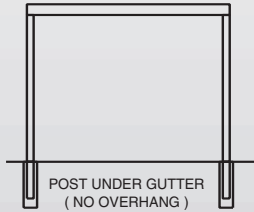

GABLE CANOPY

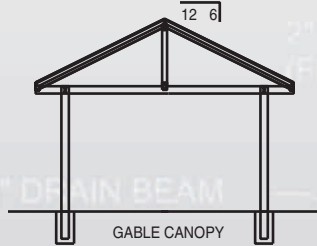

DOUBLE OVERHANG

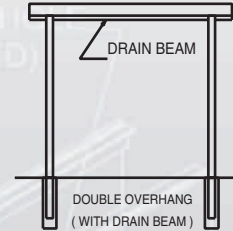

BUS CANOPY

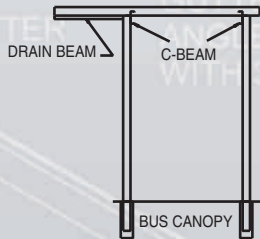

OVERHEAD SUPPORT

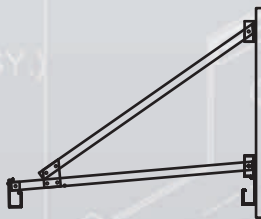

SINGLE OVERHANG

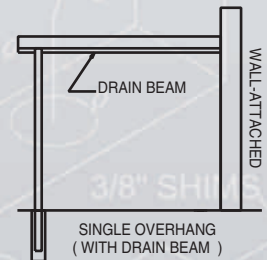

STRUCTURAL COMPONENTS



3" X 3" X .125
EXTRUDED
ALUMINUM
COLUMN



4" X 4" X .125
EXTRUDED
ALUMINUM
COLUMN



6" X 4-1/2" X .188
EXTRUDED
ALUMINUM
COLUMN



6" X 6" X .188
EXTRUDED
ALUMINUM
COLUMN

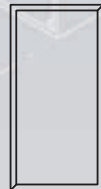

8" X 4" X .250
EXTRUDED
ALUMINUM
COLUMN



8" X 2-1/2"
12 GA. STEEL
C-BEAM



8" X 4" X .350
EXTRUDED
ALUMINUM
C-BEAM



10" X 2-1/2" X .150
EXTRUDED
ALUMINUM
C-BEAM



3" X 3"
14 GA. STEEL
COLUMN



5-1/2" X 3" X .100
EXTRUDED
ALUMINUM
FASCIA/GUTTER



6" X 1" X .094
EXTRUDED
ALUMINUM
SIDE FASCIA

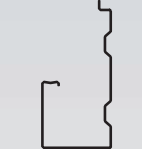

6" X 3" X .050
ROLLFORMED
ALUMINUM
FASCIA/GUTTER



7" X 3" X .094
EXTRUDED
ALUMINUM
FASCIA/GUTTER



7" X 4" X .094
EXTRUDED
ALUMINUM
FASCIA/GUTTER



6" X 3" X .125
EXTRUDED
ALUMINUM
DRAIN BEAM



6" X 4" X .125
EXTRUDED
ALUMINUM
DRAIN BEAM

STANDARD COLORS

Pictured: Superior's 7" X 3" Extruded Aluminum Fascia/Gutter

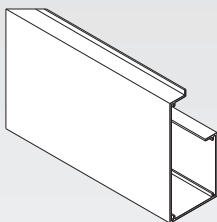

WHITE

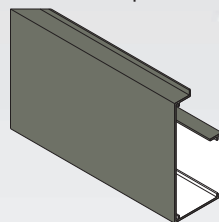

BRONZE

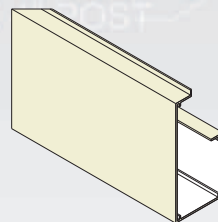

CREAM

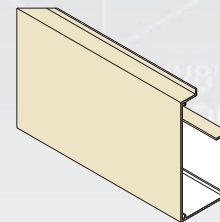

TAN

Clear anodized and Bronze anodized also available. Call for information on additional colors and availability.

Please Note: Superior cannot guarantee an exact color match with this sample chart and actual materials. Some color deviation is normal and expected.

SUPERIOR METAL PRODUCTS COMPANY, INC.

email: canopsales@superiormetalproducts.com

SUPERIOR Extruded Decking

ECONO DECKING

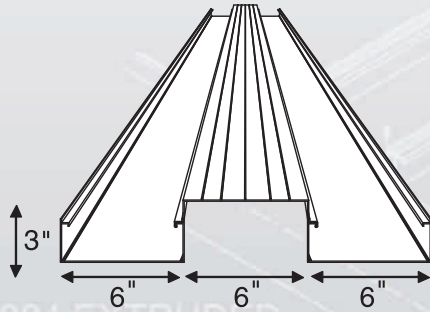

.062 6063-T6 extruded aluminum decking sections offer maximum economy for spans to 14' 8" at 20 p.s.f. live load L/60 deflection.

FLUSH DECKING

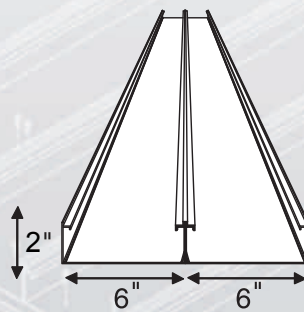

.062 6063-T6 extruded aluminum decking sections provide smooth underside to decking system with no exposed openings for spans to 16' 2" at 20 p.s.f. live load and L/60 deflection.

LONG SPAN DECKING

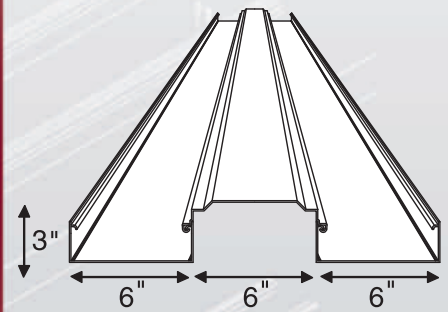

.075 6063-T6 extruded aluminum decking sections allow increased column of bent aluminum decking sections allow increased column of bent spacing for spans to 20' 0" at 20 p.s.f. live load limiting deflection to L/60.

REF: #95131 Compliance Report

8" X 4" X .350 EXTRUDED ALUMINUM C-BEAM (6063 - T6)

Proj.	20 psf	30 psf	40 psf
5'	34'0"	28'3"	24'9"
	(34'8")	(30'8")	(27'10")
6'	31'0"	25'10"	22'7"
	(32'7")	(28'10")	(25'5")
7'	28'9"	23'11"	20'11"
	(30'11")	(26'11")	(23'6")
8'	26'11"	22'4"	19'7"
	(29'7")	(25'2")	(22'0")
9'	25'4"	21'1"	18'5"
	(28'6")	(23'9")	(20'9")
10'	24'1"	20'0"	17'6"
	(27'1")	(22'6")	(19'8")
11'	22'11"	19'1"	16'8"
	(25'10")	(21'6")	(18'9")
12'	21'11"	18'3"	16'0"
	(24'8")	(20'7")	(18'0")
13'	21'1"	17'7"	15'4"
	(23'9")	(19'9")	(17'3")
14'	20'4"	16'11"	14'9"
	(22'10")	(19'0")	(16'8")
15'	19'8"	16'4"	14'3"
	(22'1")	(18'5")	(16'1")

SPANS IN PARENTHESIS ARE REACHED USING 6005-T5

10" X 2.5" ALUMINUM C-BEAM

Proj.	10 psf	20 psf	30 psf	40 psf
6'	25'4"	23'6"	19'4"	16'10"
8'	23'5"	20'5"	16'9"	14'7"
10'	21'9"	20'4"	15'0"	13'1"
12'	20'0"	18'7"	13'9"	11'11"
14'	17'8"	17'2"	12'9"	11'1"

5.5" EXTRUDED GUTTER (.100)

Proj.	10 psf	20 psf	30 psf	40 psf
7'	14'4"	11'4"	9'4"	8'2"
8'	13'9"	10'8"	8'9"	7'7"
10'	12'10"	9'6"	7'10"	
11'	12'5"	9'1"	7'6"	7'6"
12'	12'1"	8'9"	7'2"	
13'	11'7"	8'4"		
14'	11'2"	8'1"		

7" EXTRUDED GUTTER (.094)

Proj.	10 psf	20 psf	30 psf	40 psf
4'	22'3"	19'9"	16'4"	14'3"
5'	21'0"	17'8"	14'7"	12'8"
6'	20'0"	16'1"	13'3"	11'7"
7'	19'2"	14'11"	12'3"	10'8"
8'	18'5"	13'11"	11'6"	10'0"
9'	17'9"	13'2"	10'10"	9'5"
10'	17'2"	12'6"	10'3"	8'11"
11'	16'5"	11'11"	9'9"	
12'	15'9"	11'5"		
13'	14'11"	10'11"		
14'	13'11"	10'6"		



Beaufort High School
Beaufort, SC.

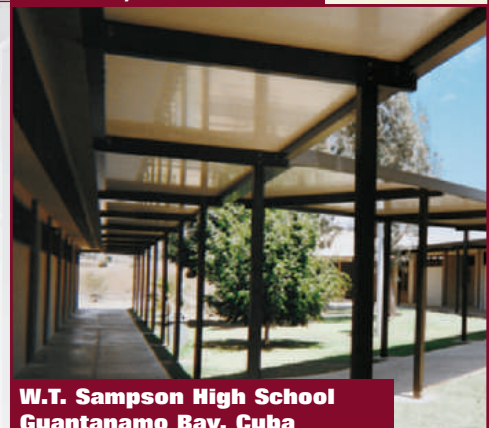

W.T. Sampson High School
Guantanamo Bay, Cuba

4

Call Toll Free: 1.877.445.1200

SUPERIOR Rollformed Panels

16" X 3" W-PAN

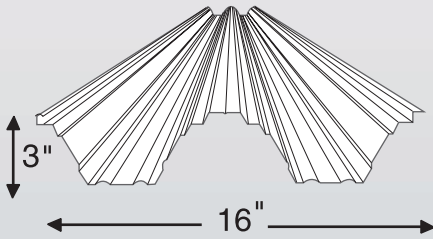

3005-H28 rollformed aluminum w-pans provide maximum coverage per dollar. Available in .018, .025 and .032 metal thickness for spans to 14' 1" at 20 p.s.f. live load and L/60 deflection.

12" X 3" FLAT PAN

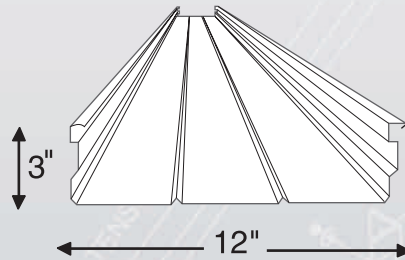

3005-H28 rollformed aluminum flat pans provide smooth underside. Available in .025 and .032 metal thickness for spans to 12' 1" at 20 p.s.f. live load and L/60 deflection.

INSULATED ROOF

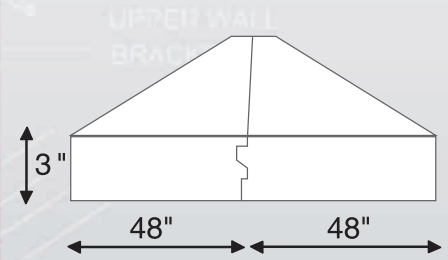

Tongue & Groove Embossed .024 aluminum coil laminated to expanded polystyrene core for 3" or 4" thick panels.

.125 EXTRUDED ALUMINUM DRAIN BEAMS

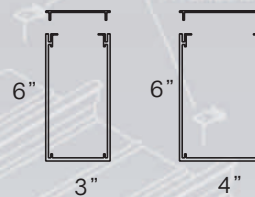

NOTE:
Spans in parenthesis are for 6" X 4" drain beam.

Proj.	20 psf	30 psf	40 psf
4'	16'4"	13'7"	11'10"
5'	(16'8")	(13'11")	(12'2")
6'	14'8"	12'2"	10'8"
7'	(15'0")	(12'5")	(10'11")
8'	13'5"	11'1"	9'9"
9'	(13'8")	(11'5")	(9'11")
10'	12'5"	10'4"	9'0"
11'	(12'8")	(10'7")	(9'3")
12'	11'7"	9'8"	8'5"
13'	(11'11")	(9'10")	(8'7")
14'	11'0"	9'1"	7'11"
15'	(11'3")	(9'4")	(8'2")
16'	10'5"	8'8"	7'6"
17'	(10'8")	(8'10")	(7'9")
18'	9'11"	8'3"	7'2"
19'	(10'2")	(8'5")	(7'4")
20'	9'6"	7'11"	6'10"
21'	(9'9")	(8'1")	(7'1")
22'	9'2"	7'7"	6'7"
23'	(9'4")	(7'9")	(6'9")
24'	8'10"	7'4"	6'5"
25'	(9'0")	(7'6")	(6'9")
26'	8'6"	7'1"	6'2"
27'	(8'9")	(7'3")	(6'4")
28'	8'3"	6'10"	6'0"
29'	(8'5")	(7'0")	6'1"
30'	8'0"	6'8"	5'9"
31'	(8'2")	(6'9")	(5'11")
32'	7'9"	6'5"	5'8"
33'	(7'11")	(6'7")	(5'9")
34'	7'7"	6'3"	5'6"
35'	(7'9")	(6'5")	(5'7")
36'	7'5"	6'1"	5'4"
37'	(7'7")	(6'3")	(5'6")

HD/OH SUPPORT

Proj.	20 psf	30 psf	40 psf
4'	19'8"	13'4"	10'0"
5'	15'8"	10'8"	8'0"
6'	13'2"	8'10"	6'8"
7'	11'2"	7'7"	5'8"
8'	9'10"	6'7"	5'0"
9'	8'8"	5'11"	4'5"
10'	7'10"	5'3"	4'0"
11'	7'1"	4'10"	3'11"
12'	6'2"	4'2"	3'8"



**UAB School of Engineering
Birmingham, AL**



**Cocke County Field House
Cocke County, TN**

SUPERIOR METAL PRODUCTS COMPANY, INC.

email: canopysales@superiormetalproducts.com

Call Toll Free: 1.877.445.1200 • Fax: 1.205.945.5694

TYPICAL APPLICATIONS

TYPICAL MECHANICAL BENT

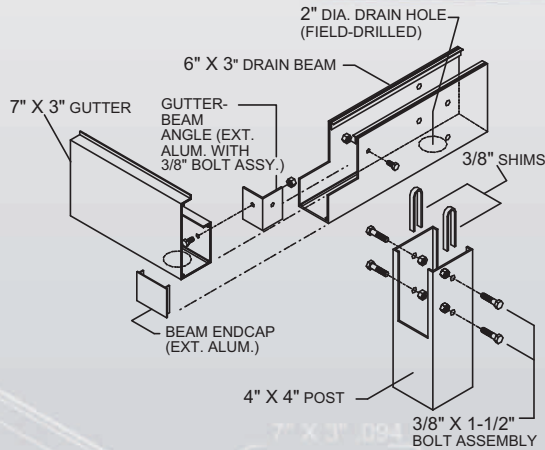

MITRED CORNER

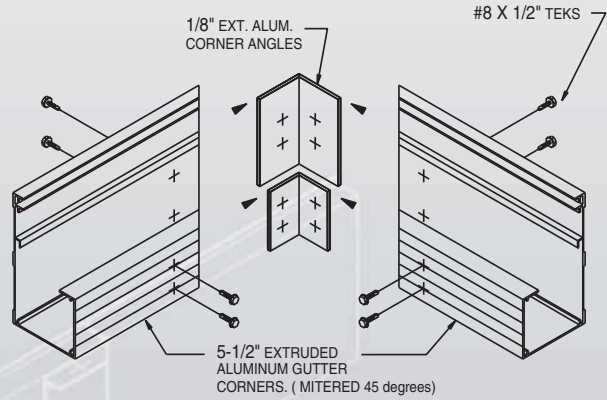

TYPICAL COLUMN @ FASCIA

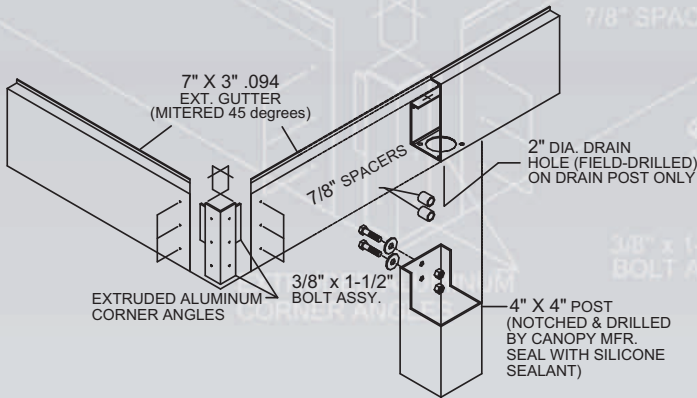

OPTIONAL FASCIA EXTENDER

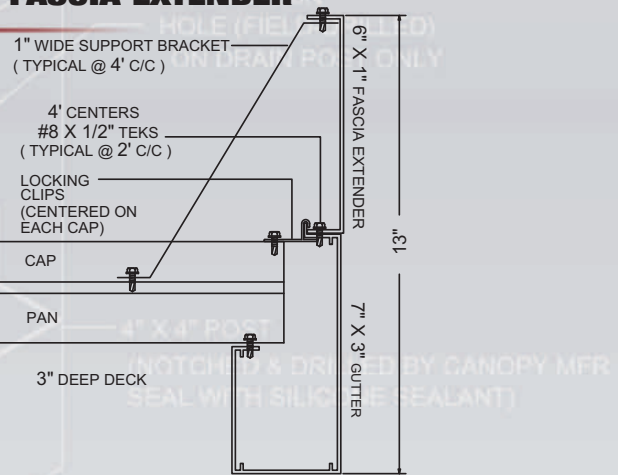

TYPICAL BLOCKOUT

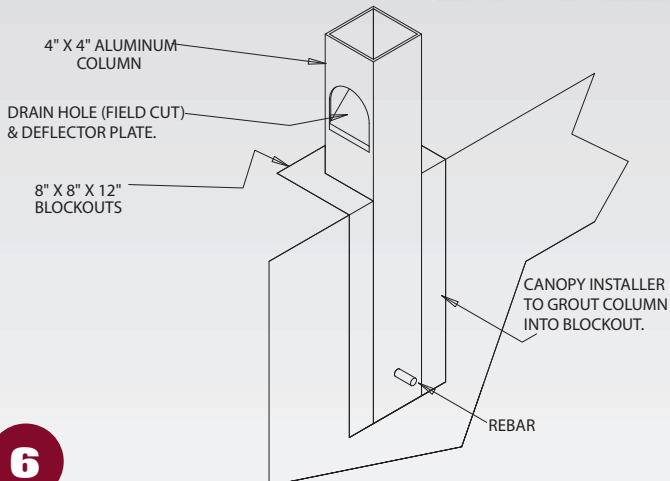

BOX OUT DETAIL

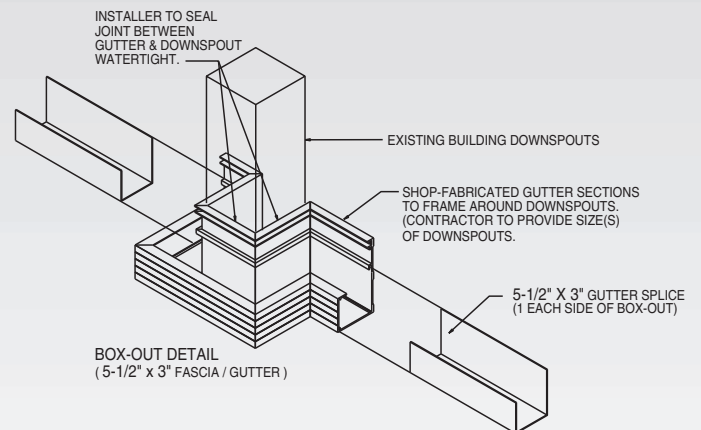

see us at
Sweets.com

ROLLFORMED CANOPY ASSEMBLY OVERHEAD SUPPORT

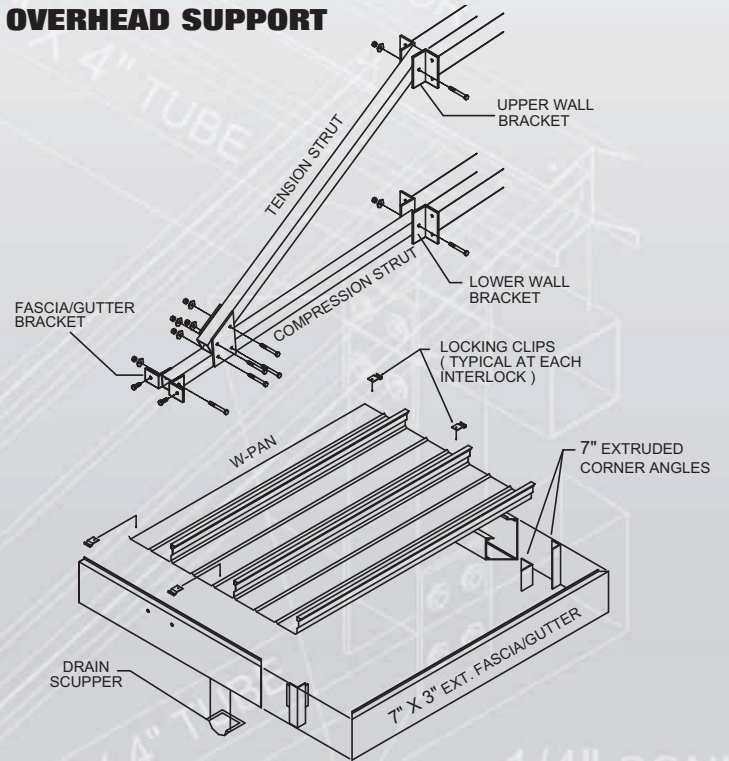
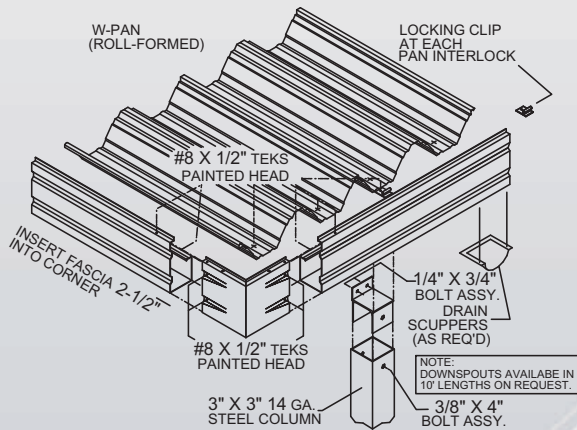

CANOPY ASSEMBLY

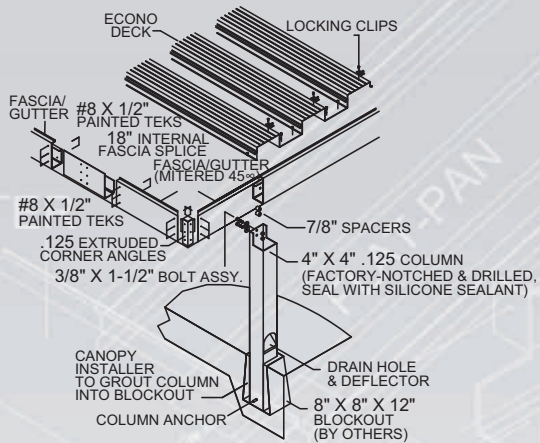

FLUSH DECK ASSEMBLY

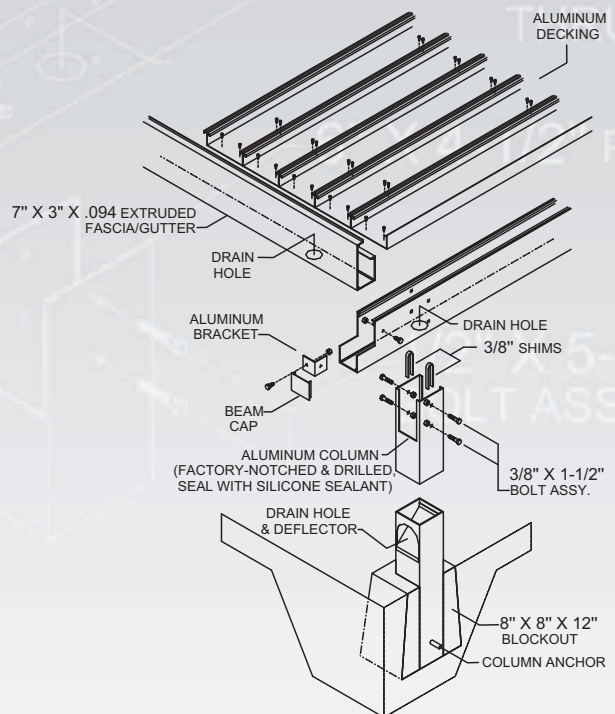

GABLE CROSS SECTION

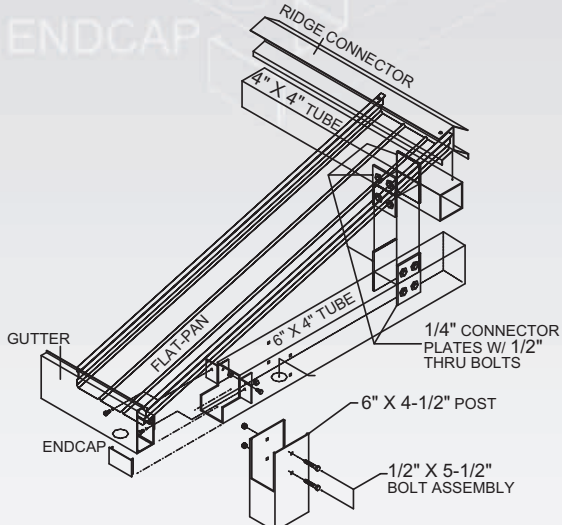



- Aluminum rollformed or extruded fascia/gutter.
- Baked-on paint finish for years of maintenance free beauty.
- 10 year Limited Warranty on material and finish.
- Every cover is custom designed and fabricated to your particular needs.
- Protect your vehicles and outdoor furniture.



- Individually designed for your home.
- Aluminum flat pan roof panels for beauty and strength.
- Your choice of 18" aluminum kickplates or none.
- Aluminum 2"X 2" horizontal rail, wall studs and corner posts for strength.

SUPERIOR ULTRAVIEW™ SUNROOMS



- Custom designed for your home and landscape.
- Vinyl horizontal sliding windows feature double-pane insulated and tempered safety glass.
- Baked enamel aluminum framing for low maintenance.
- Both window sashes are removable and operate left to right and right to left.
- Insulated walls tested up to 147 MPH wind speeds.

- 3-1/4" thick insulated wall panels provide R-13 thermal rating.
- Roof panel has R-13 Thermal Resistance value for energy savings.
- 10 year Warranty on enclosure and Lifetime Warranty on glass breakage and prolonged internal fogging.
- Optional fan beam allows for installation of fan and/or light fixture.
- Wall panels available in white or tan fiberglass and white or tan embossed aluminum.
- Electrical baseway system available.
- Tempered glass kickplates and transoms available.

MEDALLION SUNROOMS



- Insulated, tempered glass—standard for safety!
- Each window is a full 5' high for expanded viewing area.
- Both window sashes operate right to left and left to right.
- Both window sashes are removable.
- 3-inch roof has R-13 Thermal Resistance value for energy savings.

- Optional fan beam allows for installation of fan and/or light fixture.
- 2" thick insulated wall panels provide R-8.5 thermal rating.
- 10 year Warranty on enclosure and Lifetime Warranty on glass breakage and prolonged internal window fogging.
- All structural components constructed from 6063 T5 aluminum alloy with baked on enamel paint.
- Electrical baseway system available.

STORM AND SCREEN DOORS



- Full 1-1/4" thick extruded aluminum mainframe.
- 1/8" or 3/16" tempered safety glass.
- Enamel finish: bronze, cream, white or tan.
- Solid brass hardware, lever latch, keyed deadbolt (outside) thumb turn bolt (inside).
- Five heavy duty self lubricating hinges with bronze bushings.
- Brass-tone adjustable bottom expander with vinyl sweep.
- Optional platinum hardware available.

VINYL WINDOWS



- All welded frame, welded sashes.
- LoE³-366 glass and Argon Gas filled - Standard.
- 3/4" sealed insulated glass with DuraSeal™ spacer.
- Double Hung sashes tilt in and Slider sashes remove for safe, easy cleaning from inside.
- Limited Lifetime Warranty.
- Available in white and beige.

- All windows are custom manufactured to your exact measurements to ensure a perfect fit and care free operation.



SUPERIOR METAL PRODUCTS COMPANY, INC.
 116 Citation Court
 Birmingham, Alabama 35209-6307



Toll Free: 1.877.445.1200 • fax: 205.945.5694
 email: canopysales@superiormetalproducts.com