

# BALCO, INC. ILLUMITREAD™ PHOTOLUMINESCENT HANDRAIL STRIPS

## Installation Instructions

The following installation instructions are very important. Read them carefully, and be sure you understand them completely before you begin any work. Store this product in the horizontal position in a clean, dry location. Store this product in a protected area.

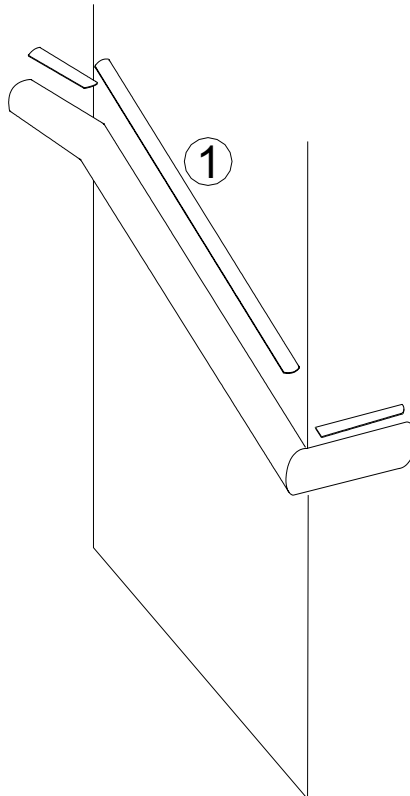

Figure 1

### Tools required :

This is a list of tools and materials recommended for use in the installation of these stair nosings. These tools and materials are not provided by Balco, Inc.

- A. Clean Rags
- B. Tape Measure
- C. Roller
- D. 3M Safety Walk Primer

### Parts:

- 1. Handrail Strip

### PROCEDURES:

These installation instructions are for use in the installation of Balco, Inc. Photoluminescent Handrail Strips. Ensure temperature of both the handrail strip and the handrail surface to receive it is 60°F or higher.

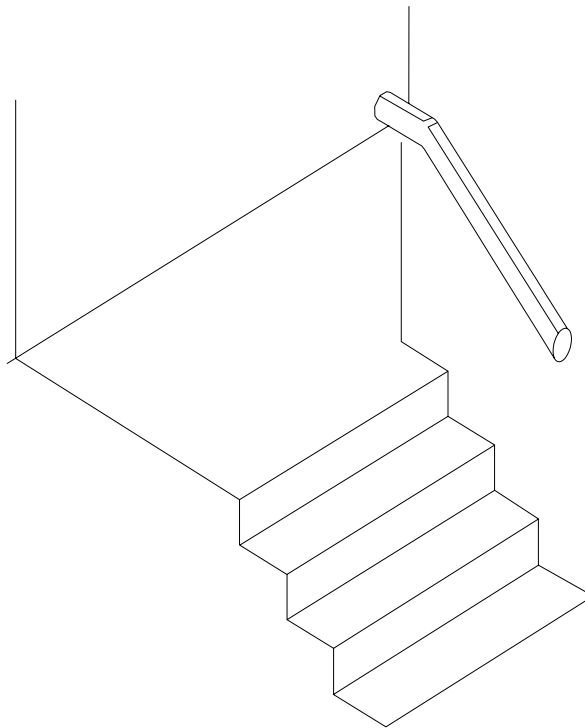

**Figure 2**

**STEP 1.** Ensure that the surface to receive the handrail strip is free of dust, oil and other contaminants. Wipe areas to receive strip with a 50/50 solution of alcohol and water. Routinely replace cleaning cloth to insure proper cleaning. Cleaning oil or greasy residue from a substrate may require a stronger solvent, such as Acetone or Naphtha. Allow the alcohol/water solution or solvent used to clean the substrate to evaporate from the substrate prior to applying the demarcation strip. If a solvent is used, ensure that the solvent will not harm the handrail cover surfaces. Follow the applicable MSDS instructions for handling, storage and use of whichever solvent is selected.

**STEP 2.** Cut and fit the strips to the desired configurations. Use a fine tooth hacksaw blade. Handrail strips should be cut from the back side of the strip.

**STEP 3.** Prior to installation of the handrail strip, coat the strip installation area with a light coat of 3M Safety Walk Primer. Allow the primer to dry for a couple of minutes. Follow the primer manufacturer's instructions for handling, application and drying of the primer.

**STEP 4.** Select a handrail strip. Peel the liner away from the tape on the back side of the strip. Apply the handrail strip at the desired location on the handrail. Ensure that the strip is positioned so as to maximize the contact area between the tape and the receiving surface. Roll the applied strip using a 15# evenly applied pressure to ensure proper contact with the substrate and pressure are applied to the strip.

**NOTE:** BALCO, INC. RECOMMENDS NEWLY APPLIED HANDRAIL STRIPS NOT BE SUBJECTED TO TRAFFIC OR STRESS FOR 24 HOURS. BALCO, INC. ALSO RECOMMENDS THAT A TEST INSTALLATION BE DONE TO ENSURE THAT THE APPLICATION AND CONDITIONS ARE SUITABLE.