

PAC SNAP EDGE FASCIA

BUILT-UP/MODIFIED VERSION

PRODUCT FEATURES

- Quick lead times to keep projects on schedule
- Economically priced and easy to install
- Pre-punched, slotted holes for precise fastener placement
- Wide variety of colors and finishes
- Convenient 12' lengths
- Reusable and recyclable material
- Efficient design eliminates need for stripping in/heat welding
- Factory fabricated miters and scuppers available
- All fasteners are included

MATERIALS

- 37 Stocked PAC-CLAD Finishes - 24 GA Steel
- 18 Stocked PAC-CLAD Finishes - .040 Aluminum
- 29 Stocked PAC-CLAD Finishes - .050 Aluminum
- 6 Stocked PAC-CLAD Finishes - .063 Aluminum
- Mill Finish Aluminum - .040, .050 & .063 Aluminum
- Clear and Colored Anodized - .040, .050 & .063 Aluminum

ACCESSORIES

- Miters – 90 Degrees and Non-90 Degrees
- Scuppers – Downspout, Spillout and Overflow
- Drainage Components

TESTING

- ANSI/SPRI ES-1 Standard to a design pressure of 200 lbs/ft² to comply with the International Building Code

WARRANTY

A 5-Year Workmanship Warranty is available. It covers replacement or repair of products that are defective in material or workmanship.

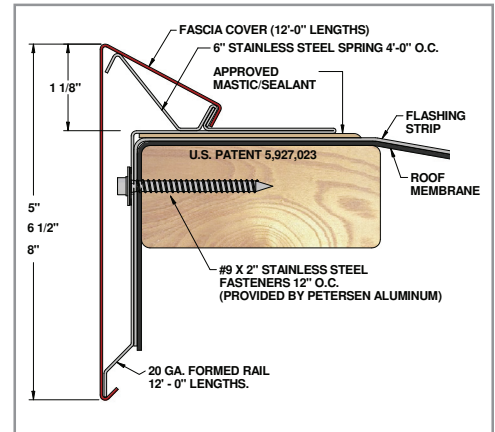

SIZES

Face Heights	Nailer Coverage
5"	2 Nailers
6 1/2"	3 Nailers
8"	4 Nailers

