

PAC-TITE WT CANTED FASCIA

GALVANIZED WATERDAM VERSION

PRODUCT FEATURES

- Unique design keeps flange out of the waterline
- Extruded aluminum anchor bar securely terminates the membrane
- Unmatched uplift protection in roof edge applications
- Snap-On cover eliminates crimping
- Pre-punched holes for precise fastener placement
- Includes anchor bar EPDM splice plates and required fasteners
- Concealed splice plates allow for cleaner design
- Non-penetrating design eliminates need for stripping in/heat welding
- Superior watertight integrity of the installation
- Extensively tested to exceed industry standards
- Slotted holes allow for thermal movement
- Lifetime, 170 mph wind warranty available
- Wide variety of colors and finishes
- Convenient 12' Lengths
- Custom and radius capabilities available
- Reusable and recyclable for reinstallation

MATERIALS

- 29 Stocked PAC-CLAD Finishes – .050 Aluminum
- 6 Stocked PAC-CLAD Finishes – .063 Aluminum
- Mill Finish Aluminum – .050 & .063 Aluminum
- Clear and Colored Anodized – .050 & .063 Aluminum

ACCESSORIES

- Miters – 90 Degrees and Non-90 Degrees
- Scuppers – Downspout, Spillover and Overflow
- Drainage Components

TESTING

- ANSI/SPRI ES-1 Standard to a design pressure of 190 lbs/ft² to comply with the International Building Code
- Factory Mutual 1-270 approved for wind up lift protection
- Miami Dade Approved to comply with the High Velocity Hurricane Zone of the Florida Building Code

WARRANTY

A Lifetime 170 mph warranty is available. It covers replacement or repair of any portion of the roof edge system that has failed due to a defect in the supplied materials. The warranty covers the roof edge for the lifetime of the roof on which it was originally installed.

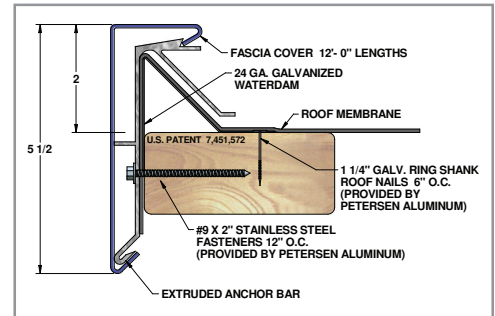

APPROVED

SIZES

Face Heights

5 1/2"

