



WMS-MONITOR MOUNT

Wall Mount Shelf Models

SPECIFICATION DATA

DA-LITE SCREEN COMPANY, INC.
 3100 North Detroit Street
 Post Office Box 137
 Warsaw, Indiana 46581-0137
 Phone: 574-267-8101
 800-622-3737
 Fax: 574-267-7804
 Toll Free Fax: 877-325-4832
 www.da-lite.com
 e-mail: info@da-lite.com

SUGGESTED SPECIFICATIONS: Da-Lite/Advance wall mount shelf Model **WMS** _____ shall be mounted where indicated on plans. The mount shall be a fabricated mild steel design consisting of a single support arm, a monitor shelf, and an adjustment bracket. The mount support arm shall be formed from 1 1/2" x 2" x 11-gauge rectangular tubing. It shall support the monitor shelf at a location _____ inches from the wall. The monitor shelf shall be 16-gauge, perforated, and shall have a minimum 1/2" formed lip to restrict monitor travel. The 11-gauge adjustment bracket shall allow the shelf to tilt forward 0° through 15° and swivel 360°. The mount package shall be equipped with a ratchet tensioning safety belt for added security. Mount packages shall be UL / C-UL listed and comply to UL 1678 to safely hold a _____ inch diagonal screen TV/monitor to _____ wall construction with 3/8" diameter fasteners. A wall bracket may be required for compliance to the UL standard. The wall bracket shall be fabricated from two 1 1/4" x 16-gauge square steel tubes joined to an 11-gauge steel channel by MIG welding. Mount assemblies shall have a commercial powder coat black finish. All tubing shall be finished with black end closures and shall conceal all 3/8" diameter attachment hardware.

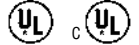

To comply with the UL load test standard of at least four times the monitor's weight, the fasteners used to install the mount or wall bracket shall be selected from the following options:

- 3/8" x 2 1/2" hex head lag screws for wood stud structural walls
- 3/8"-16 Hollow Set Drop-In with hex head cap screws for solid concrete structural walls
- 3/8"-16 Toggle® with hex head cap screws for hollow concrete block and steel stud structural walls

Specification Data

WMS mount information

Model	Diagonal Screen Size	Location from Wall	Max. TV/Monitor Weight	Monitor Shelf Size (w x d)
WMS-12	13" - 17"	12 1/2"	25 lbs.	12" x 9 1/4"
WMS-22	17" - 20"	16"	50 lbs.	22" x 13 1/2"
WMS-25	25" - 27"	16"	95 lbs.	25" x 13 1/2"
WMS-31	29" - 32"	21"	135 lbs.	31" x 13 1/2"

Wall bracket information

Wall Bracket Model	Fastener Locations	Number of Fasteners	Wall Bracket Dimensions (w x h)
D16	two on 16" centers	4	18" x 18"
D24	two on 24" centers	4	26" x 18"
T16	three on 16" centers	5	34" x 18"
T24	three on 24" centers	5	50" x 18"

Wall bracket application for UL 1678 compliance using proper 3/8" diameter fasteners

Model	Wood Stud	Steel Stud	Solid Concrete	Hollow Concrete Block
WMS-12	optional	T16 or T24	optional	optional
WMS-22	optional	T16 or T24	optional	optional
WMS-25	optional	T16 or T24	optional	optional
WMS-31	D16, D24, T16, or T24	T16 or T24	D16, D24, T16, or T24	D16, D24, T16, or T24

Optional Mount Accessories:

- | | | | |
|----------------------------------|---|-----------------------------------|---|
| <input type="checkbox"/> VP-1S | Video Player Mount (single DVD/VCR mount) | <input type="checkbox"/> WCB16 | Wall Corner Bracket |
| <input type="checkbox"/> VP-STK | Video Player Mount (double DVD/VCR mount) | <input type="checkbox"/> WMSWP-16 | Wall Plate (pre-construction stud span plate) |
| <input type="checkbox"/> VP-LK | Video Player Mount Lock Kit | <input type="checkbox"/> WMSWP-24 | Wall Plate (pre-construction stud span plate) |
| <input type="checkbox"/> TVM-LK | TV Mount Lock Kit | | |
| <input type="checkbox"/> A101 | Hardware Kit Solid Concrete | <input type="checkbox"/> D16 | Wall Bracket (two fasteners on 16" centers) |
| <input type="checkbox"/> A105 | Hardware Kit Wood Stud | <input type="checkbox"/> D24 | Wall Bracket (two fasteners on 24" centers) |
| <input type="checkbox"/> A109 | Hardware Kit Steel Stud, Hollow Concrete Block | <input type="checkbox"/> T16 | Wall Bracket (three fasteners on 16" centers) |
| | | <input type="checkbox"/> T24 | Wall Bracket (three fasteners on 24" centers) |
| <input type="checkbox"/> A151 | OSHPD Concrete Wall Hardware Kit - D16 or DWA16 | | |
| <input type="checkbox"/> A153 | OSHPD Wood Stud Wall Hardware Kit - WMSWP-16 or WMSWP-24 | | |
| <input type="checkbox"/> A155 | OSHPD Wood Stud Wall Hardware Kit - D16, D24, DWA16 or DWA24 | | |
| <input type="checkbox"/> A159 | OSHPD Metal Stud Wall Hardware Kit - DWA16, DWA24, WMSWP-16 or WMSWP-24 | | |
| <input type="checkbox"/> SM-1624 | OSHPD Metal Stud Wall Hardware Kit - D16 or D24 | | |

WALL MOUNT INSTALLATION OPTIONS: UNIVERSAL CONSTRUCTION WALL BRACKETS OR MOUNTING TUBE

WMS ONTO METAL STUD

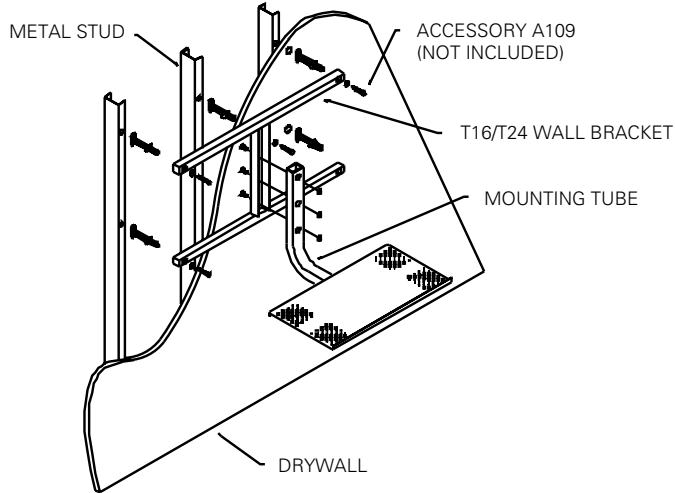

WMS ONTO HOLLOW BLOCK

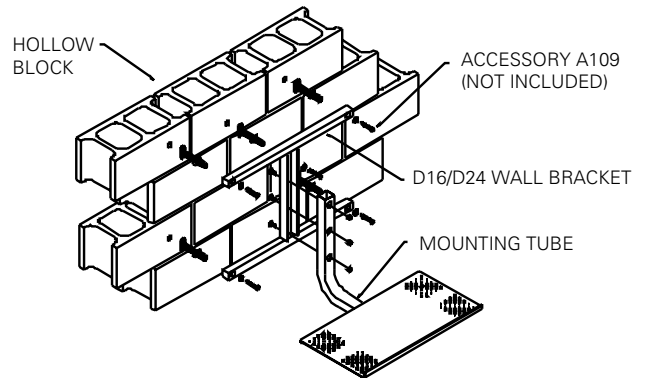

WMS ONTO CONCRETE

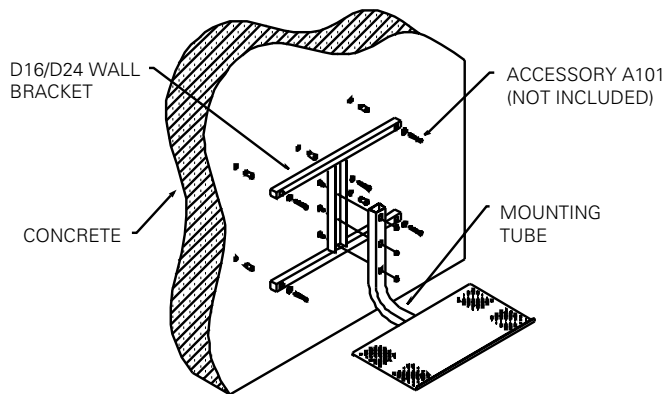

WMS ONTO WOOD STUD

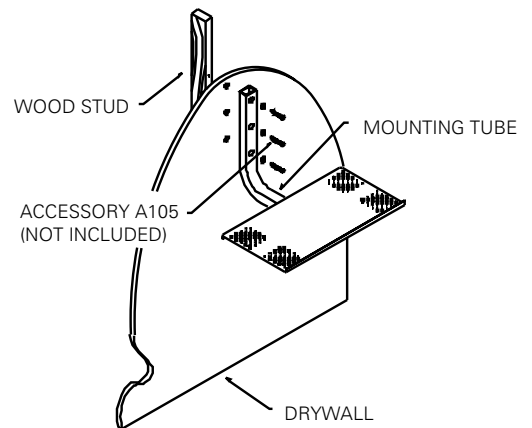

WALL MOUNT INSTALLATION OPTIONS: CONSTRUCTION SPECIFIC ACCESSORIES

WMS WITH WMSWP ONTO STUD WALL

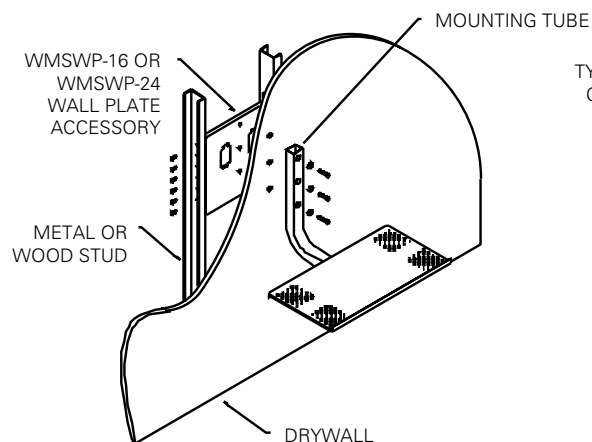

WMS WITH WCB16 ONTO CONCRETE/WOOD STUD/HOLLOW BLOCK

