

INSTALLATION INSTRUCTIONS FOR WOOD CRASH RAIL SYSTEMS WCRS-4, WCRSBT-4

STORAGE, HANDLING & ENVIRONMENTAL CONDITIONS:

1. All materials shipped unassembled. Store vertically or on flat horizontal surface.
2. Begin installation only after finish construction has been completed and building interior has been within temperature range intended for continued use for at least twenty-four (24) hours. Cut wood and aluminum components to fit only after they have been at temperature intended for continued use for twenty-four (24) hours.

INSTALLATION:

See Standard Plan Detail on reverse side for additional layout and dimensional information.

1. Measure and mark fastener centerline on wall or partition. Locate this centerline 1 1/2" below the desired height of top of crash rail.
2. Measure and mark endpoints of crash rail on wall or partition.
3. Measure and mark end cap locations and retainer lengths on wall or partition. End caps extend in 4" from end of railing. Retainer is cut 2 1/2" in from each end of railing
4. Plan retainer and crash rail lengths and mark on fastener centerline. Since the crash rail is furnished in random lengths, planning is essential to minimize joints. Because of the natural variations that occur in wood, sort wood components and match parts by color. Offset crash rail and retainer joints, if any, to maximize crash rail strength.
5. Measure and mark fastener holes on wall or partition. Locate holes on fastener centerline 32"O.C. maximum, unless otherwise specified, and at distances from retainer ends and butt joints as shown.
6. Measure and cut retainer lengths. Use longest practical lengths to minimize joints. Verify that cut lengths conform exactly to lengths marked on wall or partition.
7. Pre-drill fastener holes in wall or partition at locations marked. Make hole diameter as small as possible, allowing for fasteners. For most drywall or masonry applications, we recommend 1/4" lag screws and size "BB" Toggler brand alligator anchors by Mechanical Plastics.
8. Pre-drill fastener holes in retainer lengths to align with holes in wall or partition. Make hole diameter as small as possible, allowing for fasteners.
9. Secure retainers to wall or partition. Insert fasteners through holes in retainer and into holes in wall or partition, and secure per fastening conditions shown on the reverse side.
10. Install one end return. Slide return into position on aluminum retainer, and attach by drilling a 5/32" hole through the bottom of the retainer up into the wood end cap. Secure in place with one of the #8x3/8" screws provided.
11. Install crash rail. Slide onto retainer and locate tight against end return. Secure every 18" with the #8x3/8" screws up through the retainer from below.
12. Install remaining end cap.
13. Touch up wood surfaces. Using the touch-up sticks or stain provided, go over any nicks or joints on the finished rail.
14. For BT models: Starting at one end, press the bumper cushion in to the grooves on the return, crash rail, and opposite return take care not to stretch the cushion when pressing it in. It will shrink back to its original size, leaving a gap. Trim the bumper to length.

PARTS LIST

WCRS-4, WCRSBT-4

(WCRS-4 SHOWN)

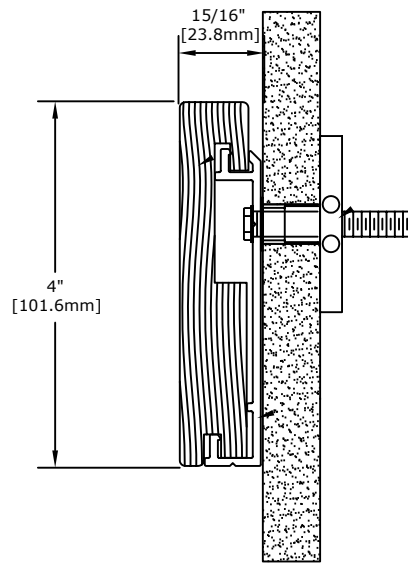

PARTS LIST

WOOD CRASH RAIL #W110-X
ALUMINUM RETAINER #A057
RIGHT END RETURN #W214-X
LEFT END RETURN #W215X
ATTCHMENT SCREW #838
BUMPERETTES #V117BLACK
(OPTIONAL)

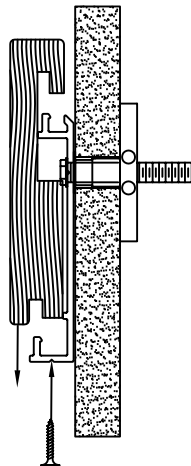

ASSEMBLY DETAIL WCRS-4, WCRSBT-4

(WCRSBT-4 SHOWN)

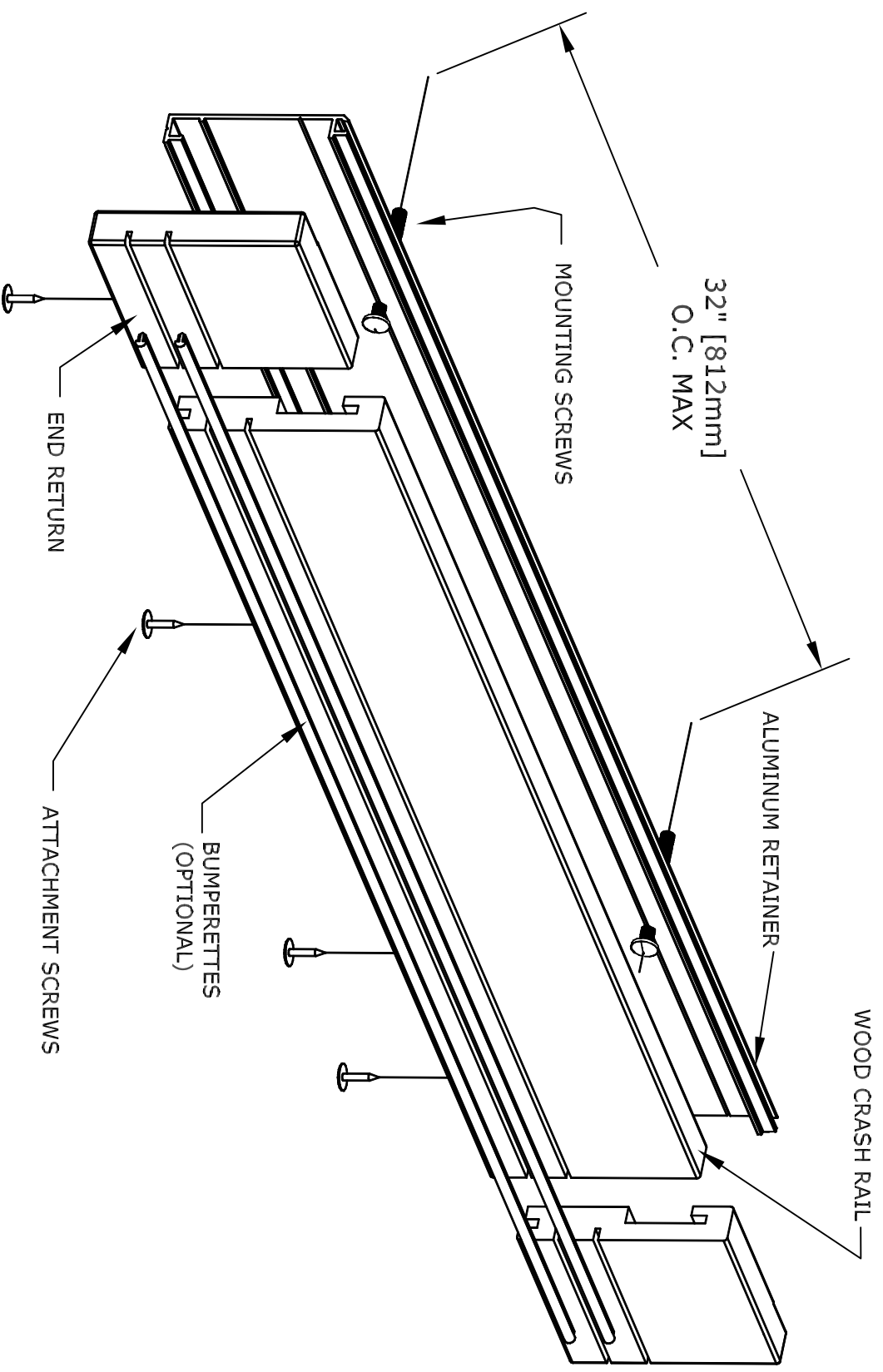

Arden
Architectural
Specialties, Inc.™

151 FIFTH AVE. NW SUITE J ST. PAUL, MN 55112-3268
TOLL-FREE 800.521.1826 TEL 651.631.1607 FAX 651.631.0251

STANDARD PLAN DETAIL WCRS-4, WCRSBT-4

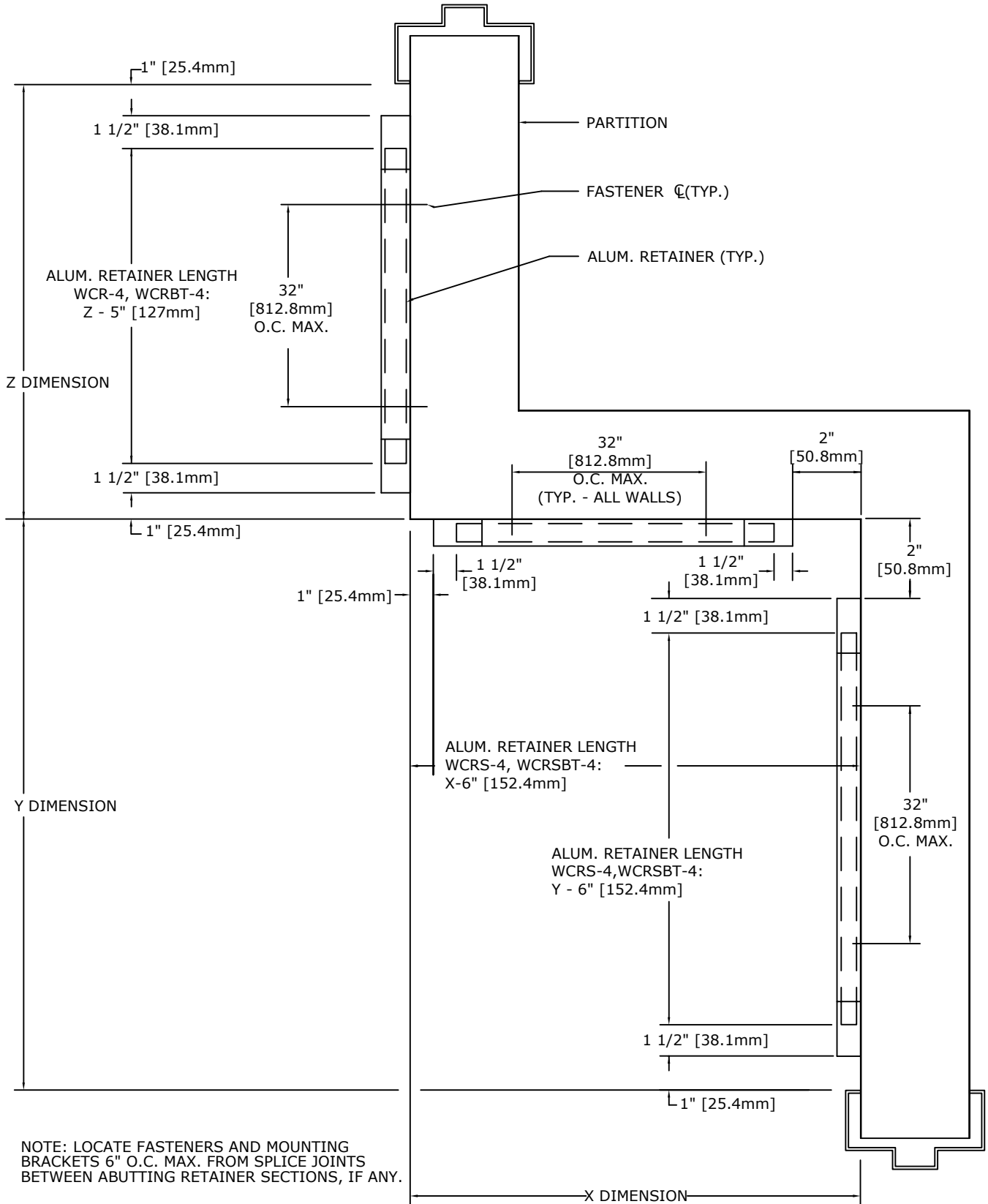

FASTENER HEIGHT WCRS-4, WCRSBT-4

(WCRSBT-4 SHOWN)

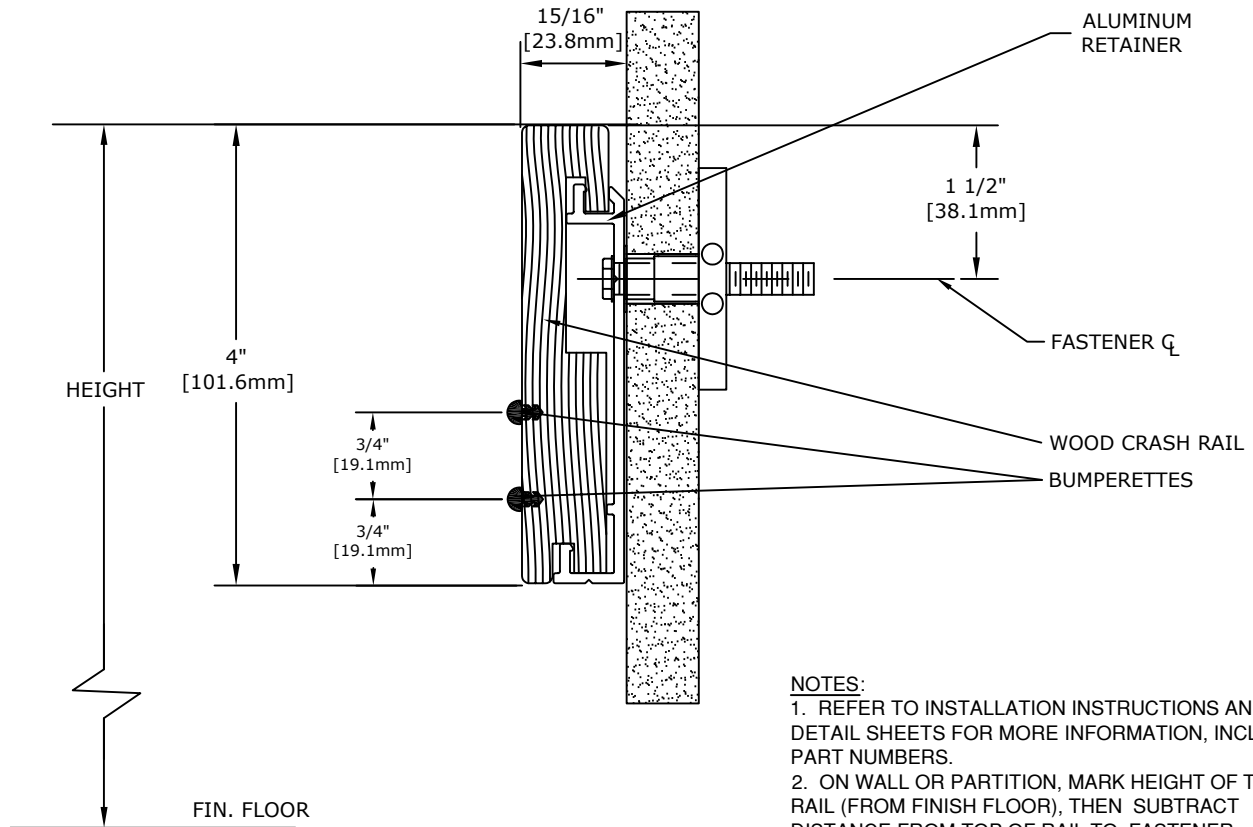

NOTES:

1. REFER TO INSTALLATION INSTRUCTIONS AND DETAIL SHEETS FOR MORE INFORMATION, INCLUDING PART NUMBERS.
2. ON WALL OR PARTITION, MARK HEIGHT OF TOP OF RAIL (FROM FINISH FLOOR), THEN SUBTRACT DISTANCE FROM TOP OF RAIL TO FASTENER CENTERLINE.

IMPORTANT: USER SHALL VERIFY CONFORMANCE OF ALL CONSTRUCTIONS SHOWN WITH LOCAL CODES AND WITH REQUIREMENTS OF METAL STUD MANUFACTURER FOR RATINGS. FASTENERS AND PARTITION COMPONENTS NOT BY ARDEN ARCHITECTURAL SPECIALTIES, INC.

TYPICAL FASTENING CONDITIONS SHOWN BELOW

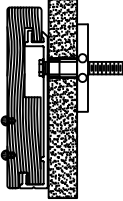
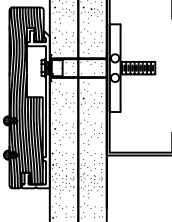
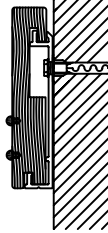
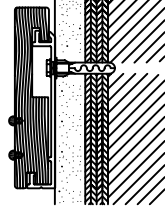
<p>1 LAYER GYP. BD.</p>  <p>1/4"-20 X 2-3/4" BOLT AND TYPE BB TOGGLER BY MECHANICAL PLASTICS</p>	<p>2 LAYERS GYP. BD.</p>  <p>1/4"-20 X 3-1/2" BOLT AND TYPE BB TOGGLER BY MECHANICAL PLASTICS</p>	<p>MASONRY</p>  <p>1/4" X 3" LAG SCREW AND TYPE AF6 ALLIGATOR ANCHORS BY MECHANICAL PLASTICS</p>	<p>GYP. BD. & MASONRY</p>  <p>1/4" X 3-1/2" LAG SCREW AND TYPE AF6 ALLIGATOR ANCHORS BY MECHANICAL PLASTICS</p>
---	--	--	--

GENERAL SPECIFICATIONS:

ALUMINUM RETAINER: ALUMINUM ALLOY TYPE 6063-T5

CRASH RAIL: FOREST STEWARDSHIP COUNCIL (FSC) CERTIFIED KILN-DRIED PREMIUM ASH, OAK, OR MAPLE, FURNISHED IN 6'-14' [1.8M-4.3M] RANDOM LENGTHS, VINYL BUMPERETTES OPTIONAL

FINISH: STAINED OR CLEAR FINISH. SEALED AND FINISHED WITH TWO COATS OF WATER WHITE CONVERSION VARNISH.



151 FIFTH AVE. NW SUITE J ST. PAUL, MN 55112-3268
TOLL-FREE 800.521.1826 TEL 651.631.1607 FAX 651.631.0251