

INSTALLATION INSTRUCTIONS CRASH RAIL SYSTEMS CRE-4A

STORAGE, HANDLING & ENVIRONMENTAL CONDITIONS:

1. All materials shipped unassembled. Store vertically or on flat horizontal surface.
2. Begin installation only after finish construction has been completed and building interior has been within temperature range intended for continued use for at least 24 hours. Cut stainless steel or aluminum components to fit only after they have been at temperature intended for continued use for 24 hours.

INSTALLATION:

1. Measure and mark centerline of rail brackets on wall or partition. This height is obtained by subtracting 2"[50.8mm] from desired height of top of rail.
2. Measure and mark location of the ends or returns, corners, and joints between abutting lengths, if any, on wall of partition centerline (see Standard Plan Detail). These marks will also indicate the location of rail-end mounting bracket fasteners.
3. Measure and mark intermediate mounting bracket fastener locations on wall or partition. Mounting brackets are required at least every 32"[812.8mm] O.C. max.
4. Drill mounting bracket fastener holes at locations marked.
5. Mount Brackets. For most drywall applications, we recommend 1/4"-20 round head bolts and 1/4" size BB strap-type Toggler brand toggles by Mechanical Plastics. For most masonry applications, we recommend 1/4" lag screws and size A-6 Toggler brand "alligator" anchors by Mechanical Plastics.
6. Mount end returns and corners.
7. Measure and cut rail sections to length as required.
8. Drill and countersink rail sections for 1/4" - 20 attachment screws, using an 9/32" drill and an 82° countersink. Drill one hole on each end of rail section, and two holes for intermediate mounting brackets using layout dimensions shown. Use care to avoid countersinking holes too deep.
9. Mount rails sections to brackets.
10. Clean rail and brackets.

PARTS LIST CRE-4A

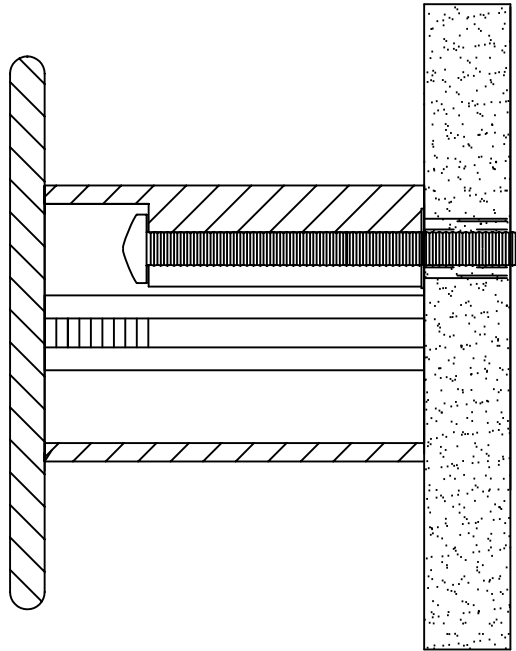

CRE-4A

4" ALUM. RAIL #A053CLR

ALUM. MOUNTING BRACKET #A056F

4" RETURN #A059

SELF TAPPING- SCREWS TO MOUNT

RAIL TO BRACKET 1/4" X 20 X 3/4" #8142034

ATTACHMENT AND CORNER DETAIL

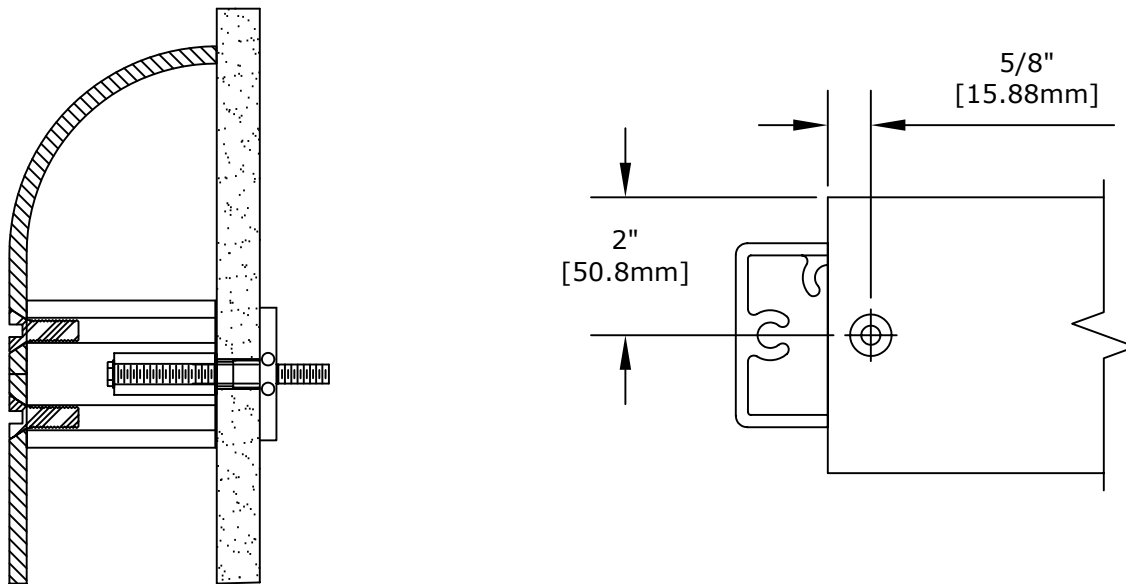

ASSEMBLY DRAWING

CRE-4A

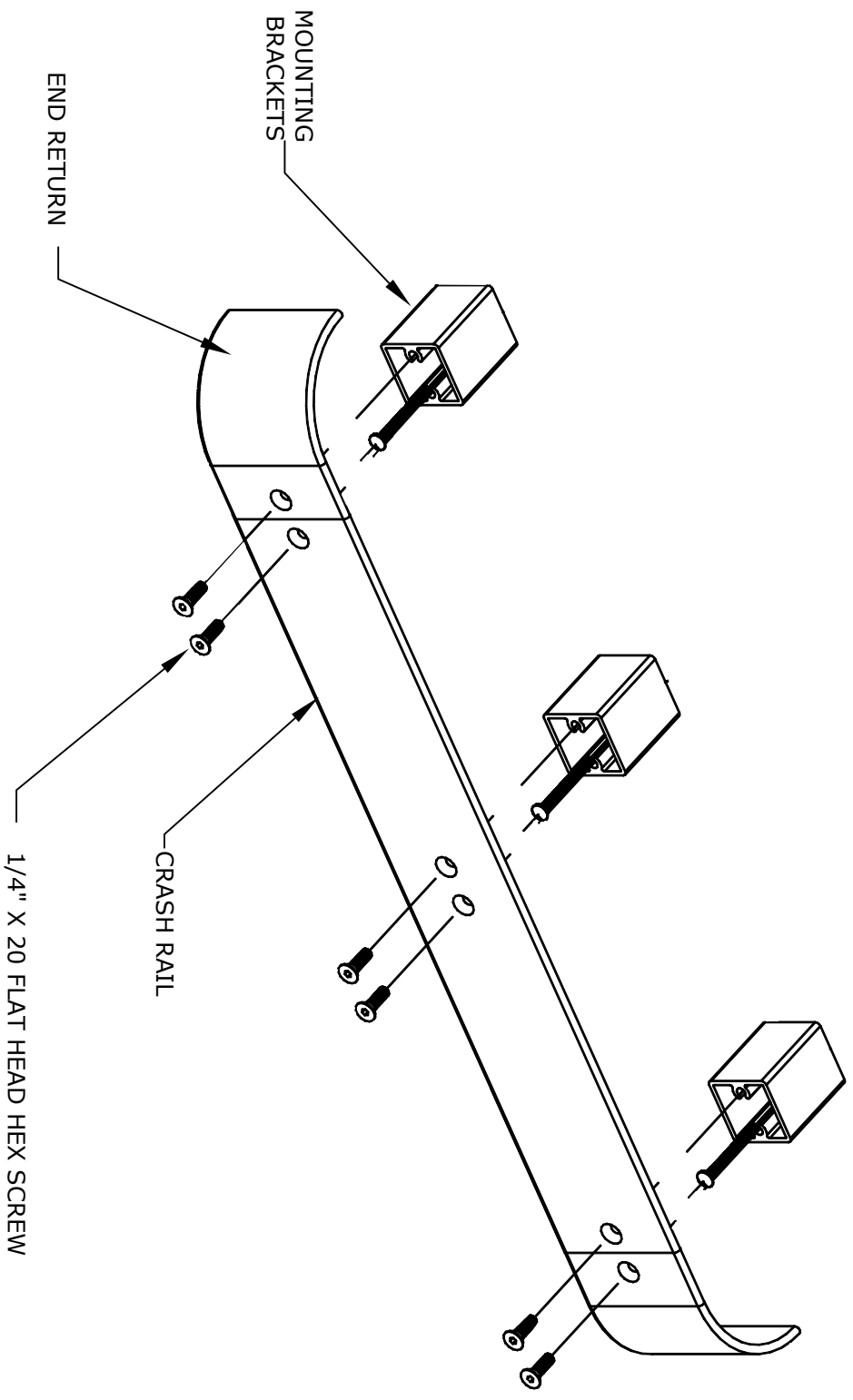

Arden
Architectural
Specialties, Inc.™

151 FIFTH AVE. NW SUITE J ST. PAUL, MN 55112-3268
TOLL-FREE 800.521.1826 TEL 651.631.1607 FAX 651.631.0251

STANDARD PLAN DETAIL

CRE-4A

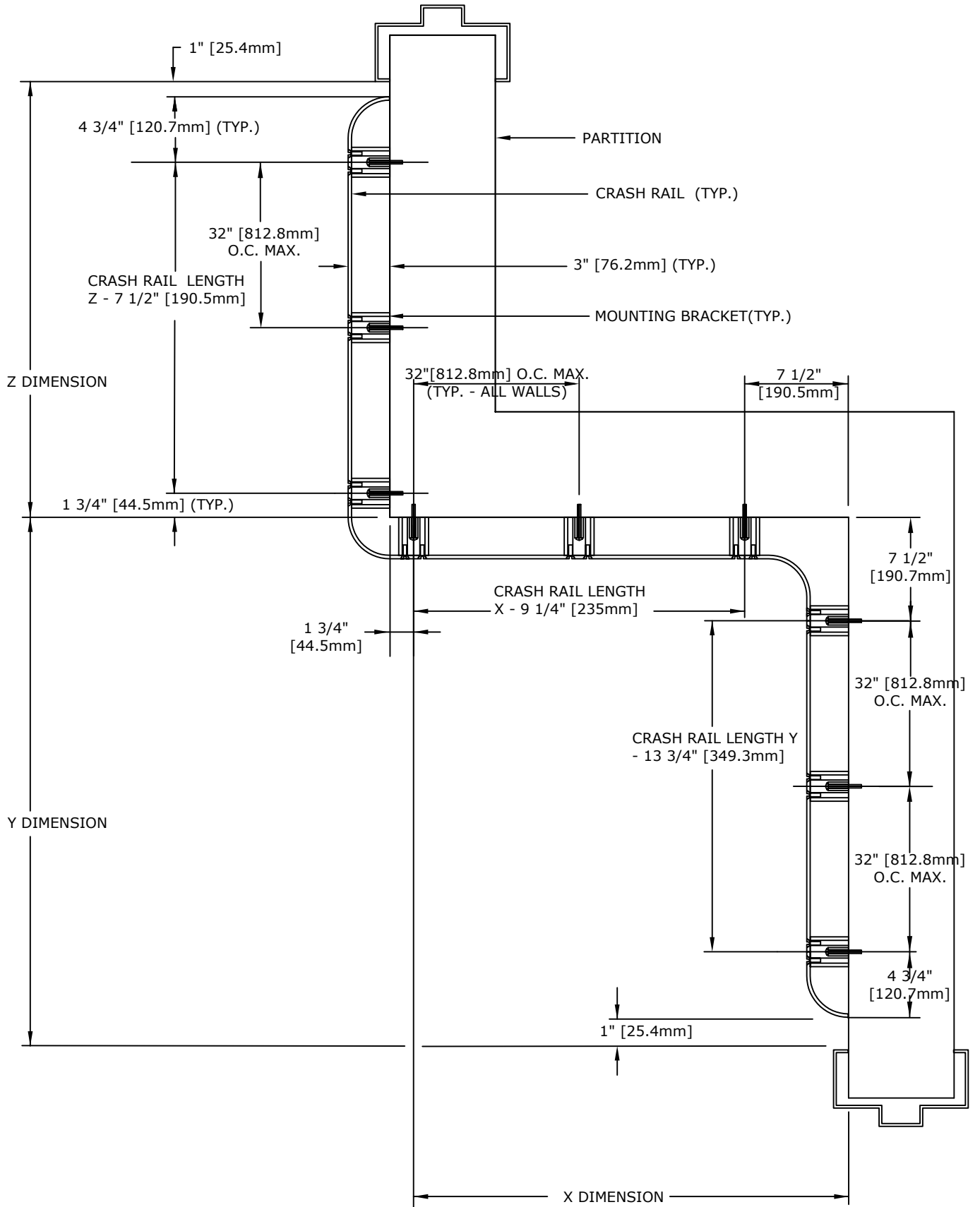

FASTENER HEIGHT CRE-4A

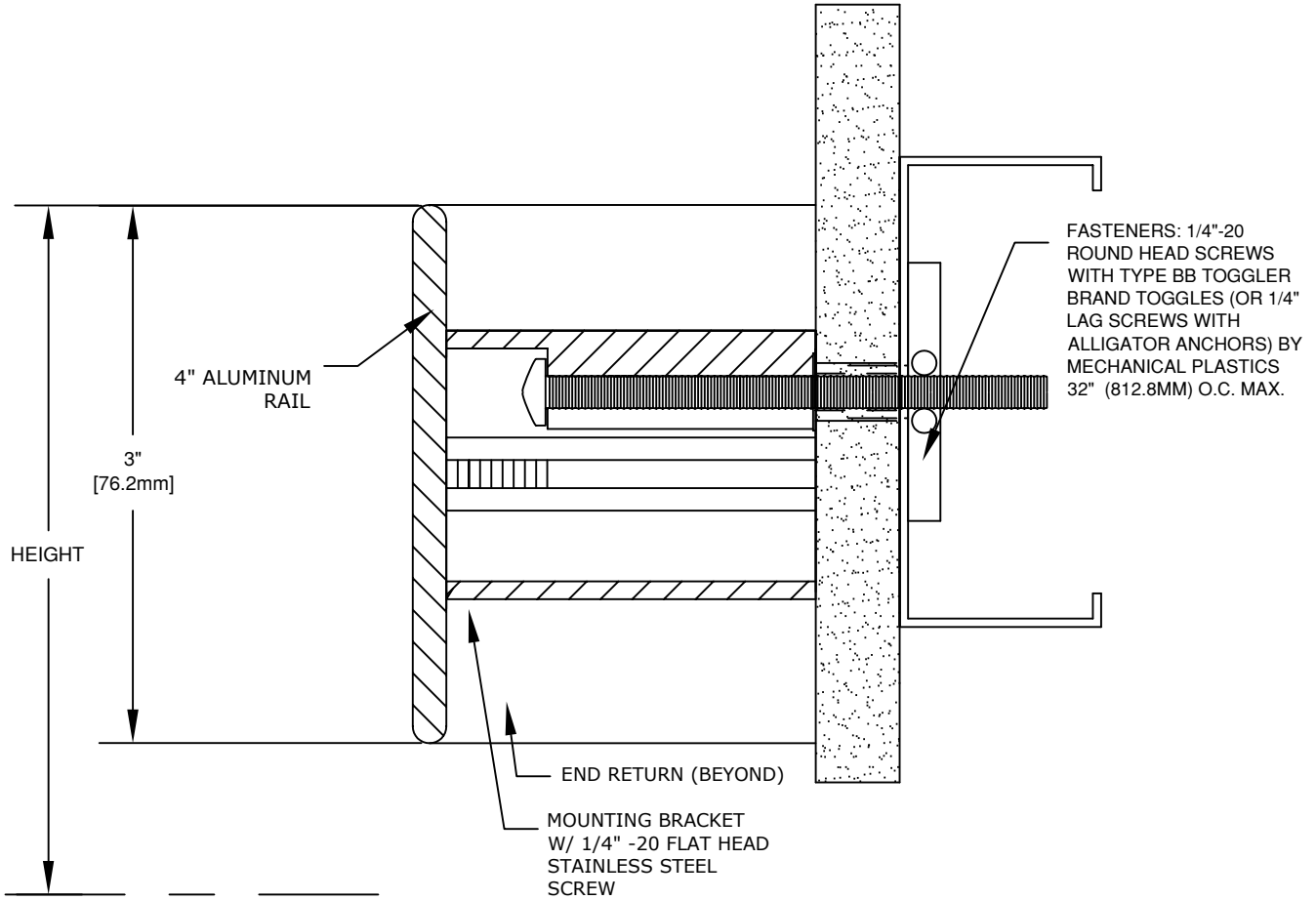

IMPORTANT: USER SHALL VERIFY CONFORMANCE OF ALL CONSTRUCTIONS SHOWN WITH LOCAL CODES AND WITH REQUIREMENTS OF METAL STUD MANUFACTURER FOR RATINGS. FASTENERS AND PARTITION COMPONENTS NOT BY ARDEN ARCHITECTURAL SPECIALTIES, INC.

TYPICAL FASTENING CONDITIONS SHOWN BELOW

1 LAYER GYP. BD.	2 LAYERS GYP. BD.	MASONRY	GYP. BD. & MASONRY
<p>1/4"-20 X 2-3/4" BOLT AND TYPE BB TOGGLER BY MECHANICAL PLASTICS</p>	<p>1/4"-20 X 2-3/4" BOLT AND TYPE BB TOGGLER BY MECHANICAL PLASTICS</p>	<p>1/4" X 3" LAG SCREW AND TYPE AF6 ALLIGATOR ANCHORS BY MECHANICAL PLASTICS</p>	<p>1/4" X 3" LAG SCREW AND TYPE AF6 ALLIGATOR ANCHORS BY MECHANICAL PLASTICS</p>
QTY:	QTY:	QTY:	QTY:

SPECIFICATION:

GENERAL: FURNISH AND INSTALL BUMPER GUARD SYSTEM(S) BY ARDEN ARCHITECTURAL SPECIALTIES, INC., AS SHOWN AND SPECIFIED.

INSTALLATION: SECURE TO WALL OR PARTITION IN ACCORDANCE WITH MANUFACTURER'S PRINTED INSTRUCTIONS. USE FASTENERS DESIGNED AND APPROVED FOR PURPOSE INTENDED, SPACED 32 INCHES [812.8mm] O.C. MAX, UNLESS SPECIFIED OTHERWISE. INSTALL SYSTEM IN ACCORDANCE WITH ALL CODES HAVING JURISDICTION.