

# INSTALLATION INSTRUCTIONS CRASH RAIL SYSTEM

## CRS-55SS, CRS-55SSV

**General:**

1. All stainless steel covers are shipped in stock lengths of 8'-0" or 10'-0" to be cut in the field to fit.
2. Carefully measure and mark all holes to be drilled to achieve a properly supported and level installation.

**Installation:**

1. Measure and mark the top of crash rail and rail system centerline on wall or partition per detail sheet.
2. Measure and mark endpoints of crash rail on the centerline.
3. Measure and cut retainer and cover sections to length for each crash rail segment (offsetting the cover joints from the wood retainer joints is recommended for a more uniform appearance.) Verify that cut lengths conform exactly to lengths marked on wall or partition. If the retainer lengths are longer than the stainless steel crash rail cover lengths, the end caps will not pull tight against the crash rail ends.
4. Debur and clean any sharp edges on the stainless steel covers as necessary.
5. Measure and mark centerline for attachment fasteners on retainer sections.
6. Measure and mark vertical centerlines for retainer attachment fasteners on this centerline. Retainer fasteners should be no more than 32" [812.8mm] on center and within 3" [76.2mm] of the end of each retainer segment.
7. Measure and mark vertical centerlines for attachment fasteners on the rail system centerline on wall or partition.
8. Drill fastener holes in wall or partition. For most drywall applications we recommend ¼" bolts and size "BB" strap type Toggler brand toggles by Mechanical Plastics. For most masonry applications we recommend ¼" screws and No. A-6 Toggler brand alligator anchors by Mechanical Plastics.
9. Drill fastener holes in retainer lengths to align with holes on wall or partition. Make holes as small as possible, allowing for fasteners.
10. Secure retainers to wall or partition. If splices were necessary, make sure adjoining sections are aligned exactly to facilitate mounting stainless covers.
11. Install covers (offsetting the cover joints from the wood retainer joints is recommended for a more uniform appearance.) Slide the top lip into the groove in the top of retainer, and rotate downward until cover is tight on retainer. Secure cover with the stainless screws provided.
12. Install endplates. Hold endplate in position, taking care to allow equal overlap of retainer at top, bottom, and front face of cover. Mark holes for attachment screws, and drill pilot holes for the #10x2" stainless steel oval head screws. Attach endplates.
13. Remove protective covering from cover and endplates and clean surfaces as necessary.



151 FIFTH AVE. NW SUITE J ST. PAUL, MN 55112-3268  
TOLL-FREE 800.521.1826 TEL 651.631.1607 FAX 651.631.0251

# PARTS LIST

## CRS-55SS, CRS 55SSV

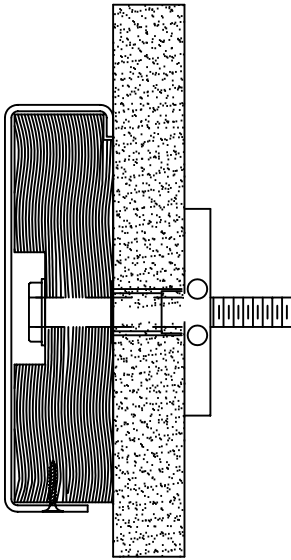

CRS-55SS

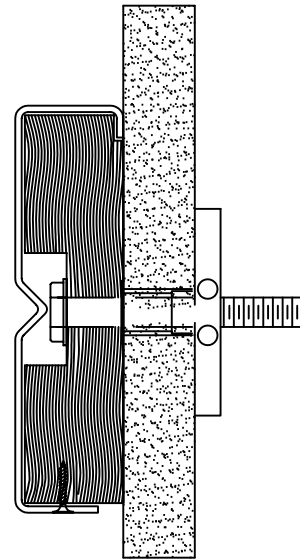

CRS-55SSV

# ASSEMBLY DRAWING

## CRS-55SS, CRS-55SSV

(CRS-55SSV SHOWN)

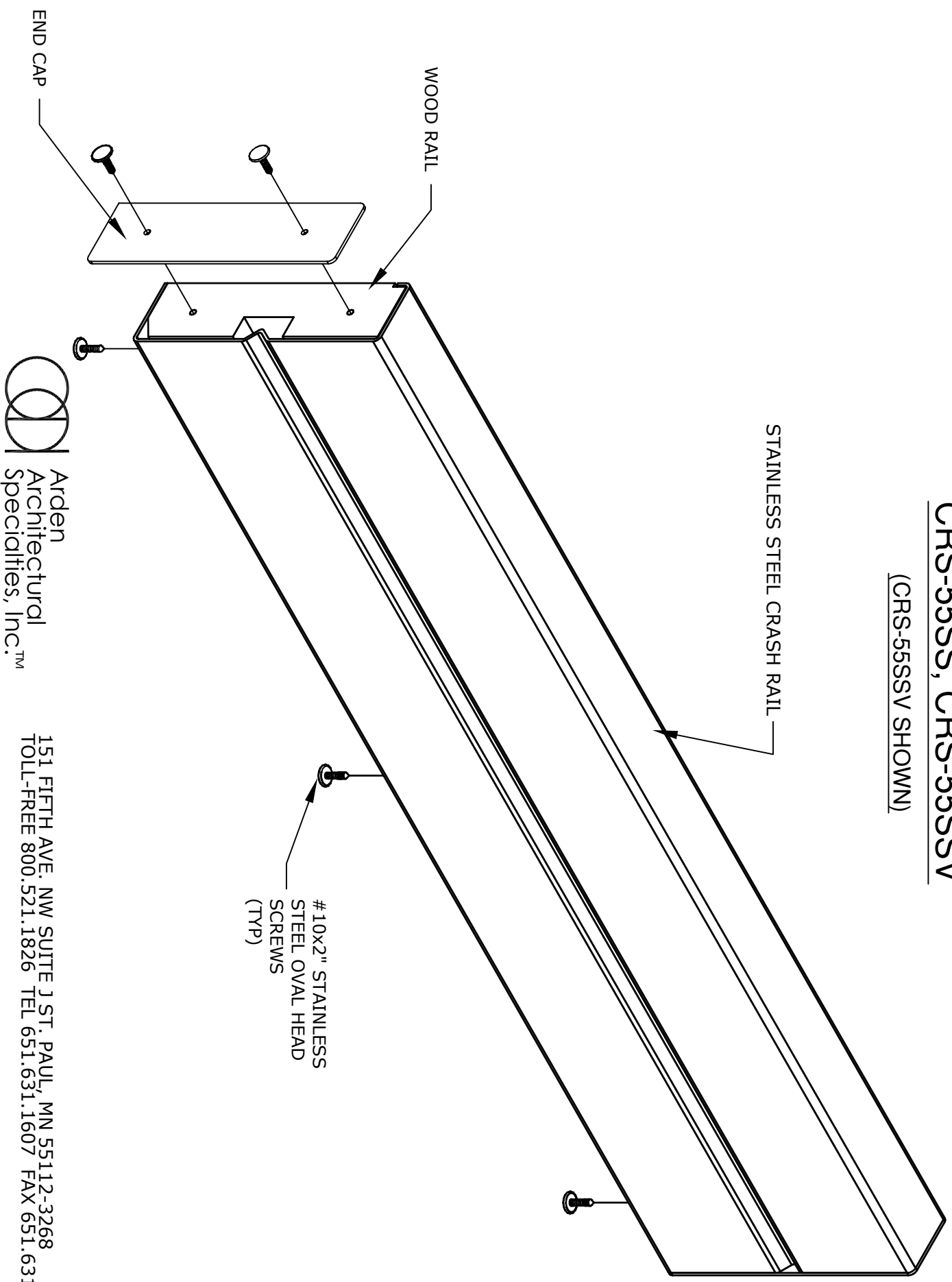

#10x2" STAINLESS  
STEEL OVAL HEAD  
SCREWS  
(TYP)

END CAP

WOOD RAIL

STAINLESS STEEL CRASH RAIL



Arden  
Architectural  
Specialties, Inc.™

151 FIFTH AVE. NW SUITE J ST. PAUL, MN 55112-3268  
TOLL-FREE 800.521.1826 TEL 651.631.1607 FAX 651.631.0251

# STANDARD PLAN DETAIL

## CRS-55SS, CRS-55SSV

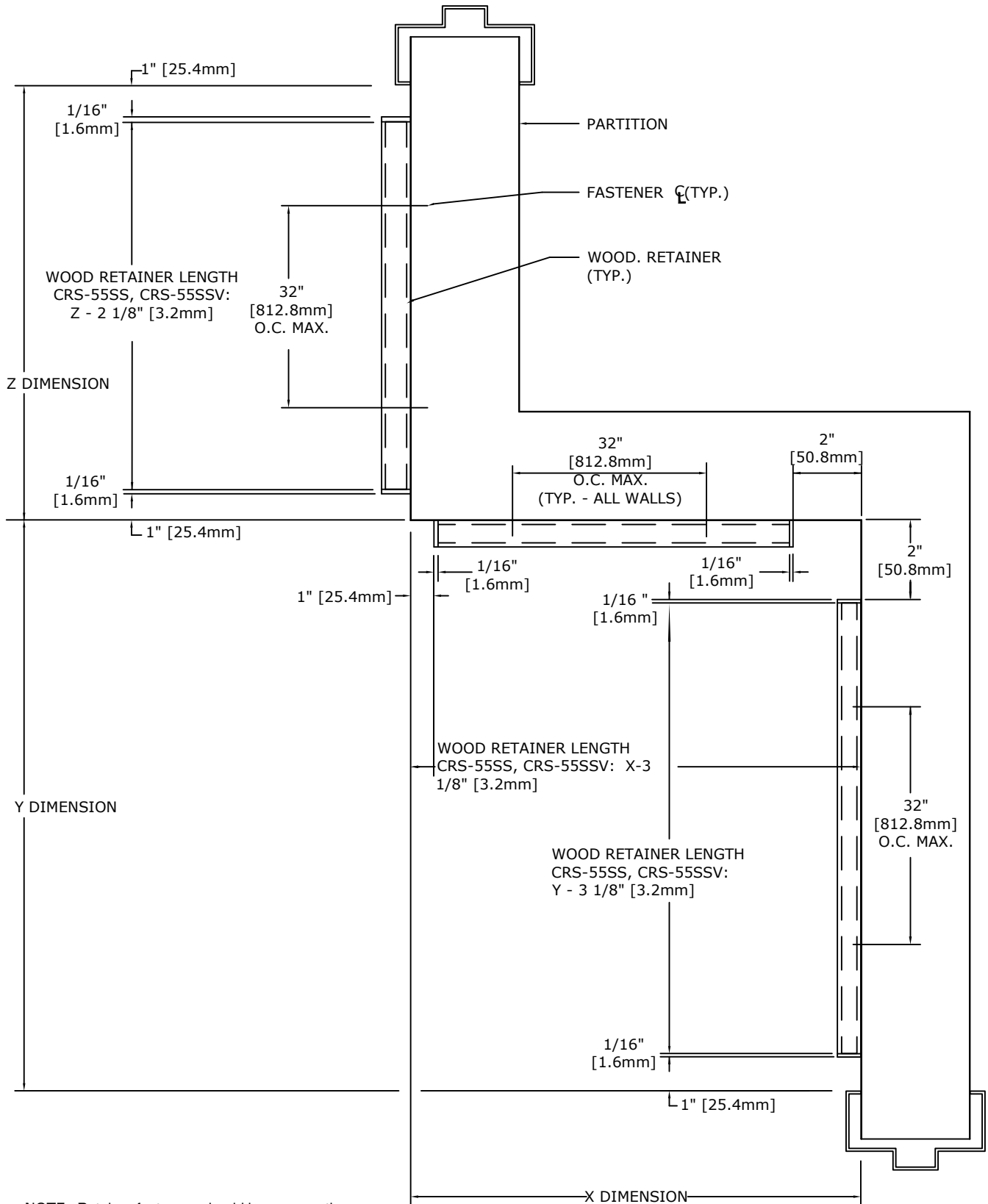

NOTE: Retainer fasteners should be no more than 32"(812.8mm) on center and within 3"(76.2mm) of the end of each retainer segment.

# FASTENER HEIGHT CRS-55SS, CRS-55SSV

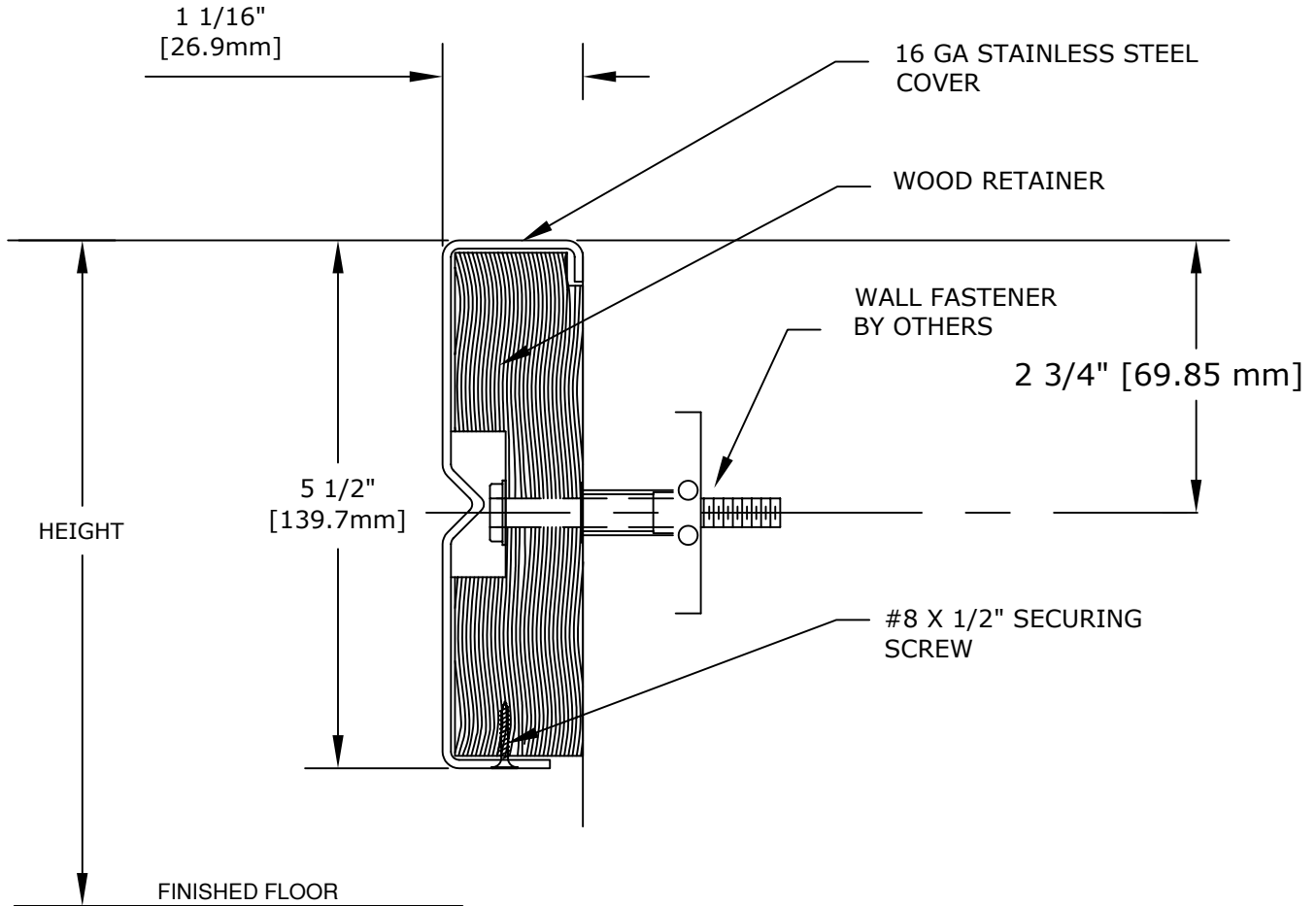

IMPORTANT: USER SHALL VERIFY CONFORMANCE OF ALL CONSTRUCTIONS SHOWN WITH LOCAL CODES AND REQUIREMENTS. FASTENERS AND PARTITION COMPONENTS NOT BY ARDEN ARCHITECTURAL SPECIALTIES, INC.

## TYPICAL FASTENING CONDITIONS SHOWN BELOW

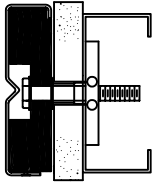
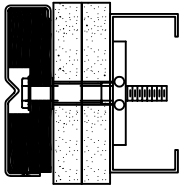
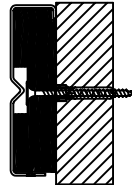
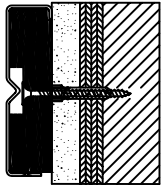
1 LAYER GYP. BD.	2 LAYERS GYP. BD.	MASONRY	GYP. BD. & MASONRY
			
<p>1/4"-20 X 2-3/4" BOLT AND TYPE BB TOGGLER BY MECHANICAL PLASTICS</p> <p>QTY:</p>	<p>1/4"-20 X 2-3/4" BOLT AND TYPE BB TOGGLER BY MECHANICAL PLASTICS</p> <p>QTY:</p>	<p>1/4" X 3" LAG SCREW AND TYPE AF6 ALLIGATOR ANCHORS BY MECHANICAL PLASTICS</p> <p>QTY:</p>	<p>1/4" X 3" LAG SCREW AND TYPE AF6 ALLIGATOR ANCHORS BY MECHANICAL PLASTICS</p> <p>QTY:</p>

**SPECIFICATION:**

**GENERAL:** FURNISH AND INSTALL CRASH RAIL SYSTEM(S) BY ARDEN ARCHITECTURAL SPECIALTIES, INC., AS SHOWN AND SPECIFIED.

**INSTALLATION:** SECURE TO WALL OR PARTITION IN ACCORDANCE WITH MANUFACTURER'S PRINTED INSTRUCTIONS. USE FASTENERS DESIGNED AND APPROVED FOR PURPOSE INTENDED, SPACED 32 INCHES [812.8mm] O.C. MAX, UNLESS SPECIFIED OTHERWISE. INSTALL SYSTEM IN ACCORDANCE WITH ALL CODES HAVING JURISDICTION.



151 FIFTH AVE. NW SUITE J ST. PAUL, MN 55112-3268  
TOLL-FREE 800.521.1826 TEL 651.631.1607 FAX 651.631.0251