

B

B

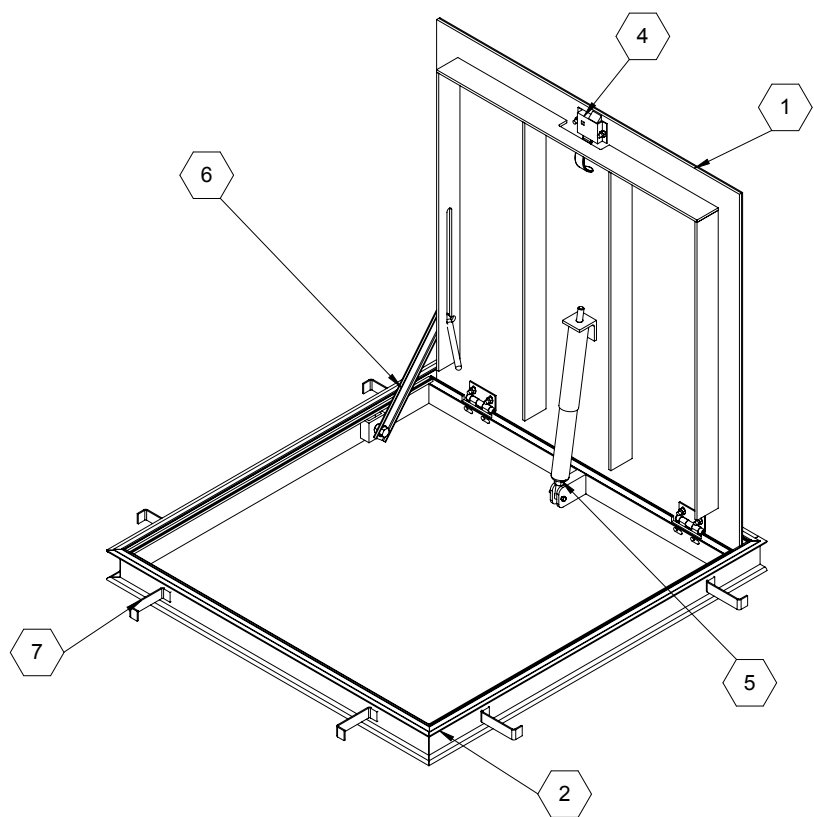
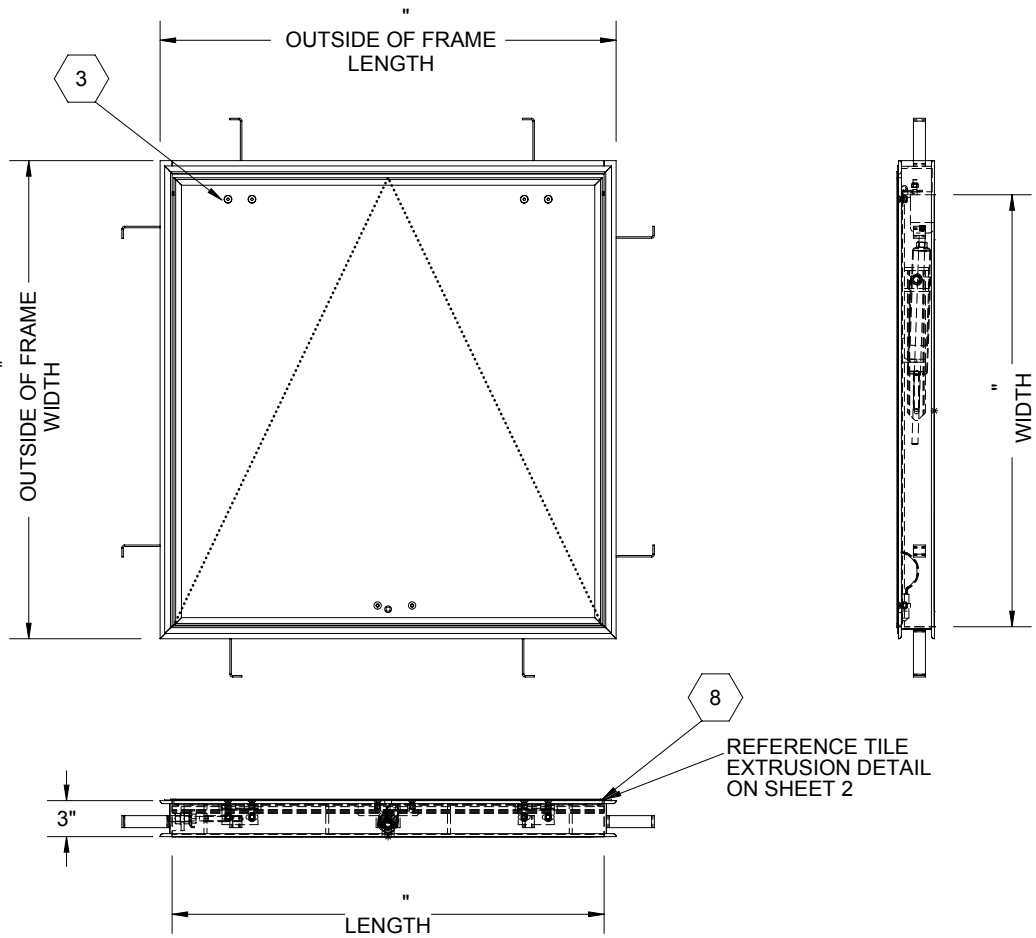

SPECIFICATIONS:

- ① **DOOR:** ALUMINUM, 1/4" SMOOTH PLATE, RECESSED, MILL FINISH WITH A LIVE LOAD OF 300 PSF WITH A MAXIMUM DEFLECTION OF L/160
 - ② **FRAME:** ALUMINUM, 1/4" EXTRUSION, RECESSED, EPOXY PAINT FINISH ON EXTERIOR SURFACES THAT COME IN CONTACT WITH CONCRETE
 - ③ **HINGES:** TYPE 316 STAINLESS STEEL
 - ④ **SLAM LATCH:** TYPE 316 STAINLESS STEEL WITH INSIDE LEVER HANDLE AND OUTSIDE REMOVABLE 5/16" SQUARE L HANDLE
 - ⑤ **COUNTER-BALANCE SPRING:** TYPE 17-7 STAINLESS STEEL SPRING ENCLOSED IN A TYPE 316 STAINLESS STEEL TELESCOPING TUBE
 - ⑥ **HOLD-OPEN ARM:** TYPE 316 STAINLESS STEEL WITH RED VINYL GRIP HANDLE
 - ⑦ **ANCHOR:** 4" CONCRETE ANCHOR STRAPS PROVIDED
 - ⑧ **TILE EXTRUSION:** ALUMINUM, RECESSED FOR 1/8" FLOOR COVERING
- FLOOR DOOR SIZE:** " (WIDTH) x " (LENGTH)
CLEAR UNOBSTRUCTED OPENING: " (WIDTH) x " (LENGTH)
OPENING: " (WIDTH) x " (LENGTH)

A

A

PROJECT:					
ARCHITECT:					
CONTRACTOR:					
QTY:					
PART#:		FDRPA X SAL			
NYSTROM Right to site.™ 9300 73rd Avenue North Brooklyn Park, MN 55428		TITLE: Floor Door, Recessed Series, Sngl Dr, 316 SST Hdw, Alum, Mill, Pedestrian, Cast-In Anchors, Slam Latch Removbl L Hdl			
		NAME	DATE	SIZE	DWG. NO.
DRAWN	JE	04/18/11	A	FDRPA_X_SAL	A
RELEASED	DWO	04/18/11	WEIGHT: Varies	SHEET 1 OF 2	

PROPRIETARY AND CONFIDENTIAL: THE INFORMATION CONTAINED IN THIS DRAWING IS THE SOLE PROPERTY OF NYSTROM. ANY REPRODUCTION IN PART OR AS A WHOLE WITHOUT THE WRITTEN PERMISSION OF NYSTROM IS PROHIBITED. THIS IS A GENERIC SHOP DRAWING AND MAY NOT BE AN ACTUAL REPRESENTATION OF THE FINAL PRODUCT.

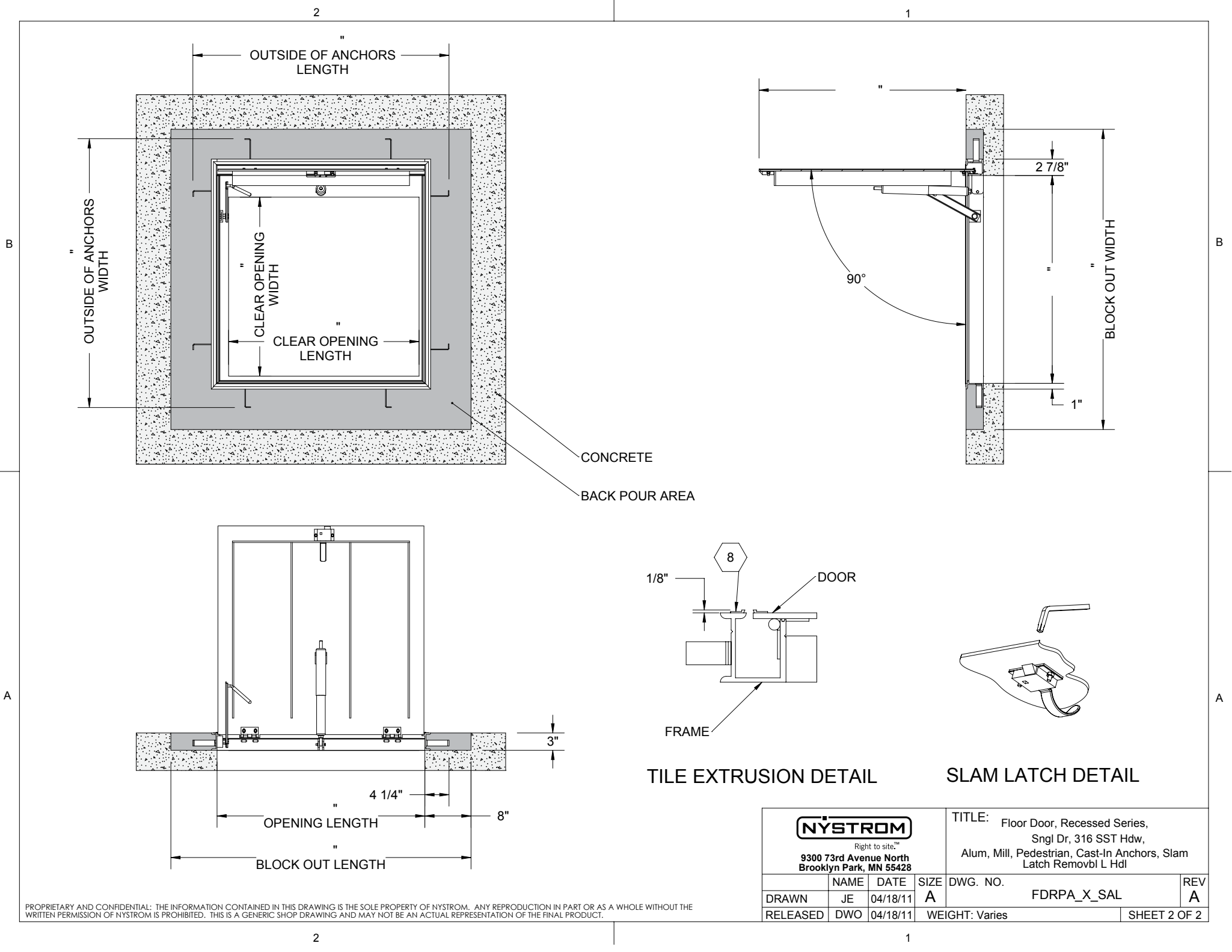

PROPRIETARY AND CONFIDENTIAL: THE INFORMATION CONTAINED IN THIS DRAWING IS THE SOLE PROPERTY OF NYSTROM. ANY REPRODUCTION IN PART OR AS A WHOLE WITHOUT THE WRITTEN PERMISSION OF NYSTROM IS PROHIBITED. THIS IS A GENERIC SHOP DRAWING AND MAY NOT BE AN ACTUAL REPRESENTATION OF THE FINAL PRODUCT.

			TITLE: Floor Door, Recessed Series, Sngl Dr, 316 SST Hdw, Alum, Mill, Pedestrian, Cast-In Anchors, Slam Latch Removbl L Hdl		
Right to site. [™] 9300 73rd Avenue North Brooklyn Park, MN 55428			DWG. NO.	FDRPA_X_SAL	REV A
DRAWN	JE	04/18/11	SIZE A		
RELEASED	DWO	04/18/11	WEIGHT: Varies	SHEET 2 OF 2	