

Overview:

Floor Door products are designed and built for years of convenient and weather tight access for personnel as well as equipment. The following are general instructions for installing, operating and maintaining floor door products intended for existing opening or bolt in applications. Frames are provided with predrilled 3/8" diameter holes. These are recommended general guidelines only. Locally accepted installation, mounting, and sealing procedures should be followed to ensure the ultimate weather-ability and structural integrity of the floors installed into various types of floor systems.

**Set Up/Unpack:****Warning**

Floor Door covers are spring loaded. Ensure proper orientation prior to releasing slam latch. Do not release latch in upside down position.

- Orient the floor door in an upright position as shown. This is the correct position to handle the floor door.
- Visually inspect slam latch from the underside to ensure latch bolt is engaged over frame.
- Cut plastic tie wrap and remove envelope.

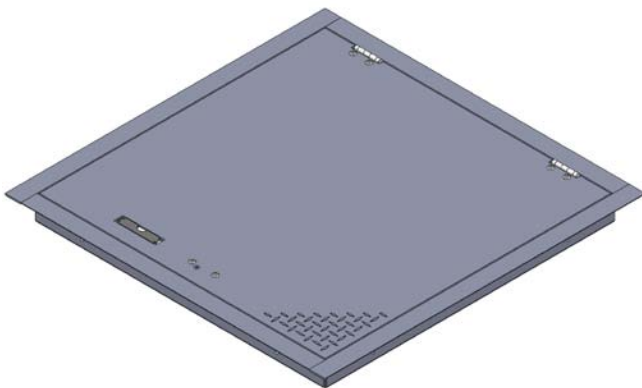

Floor Door in Upright Position

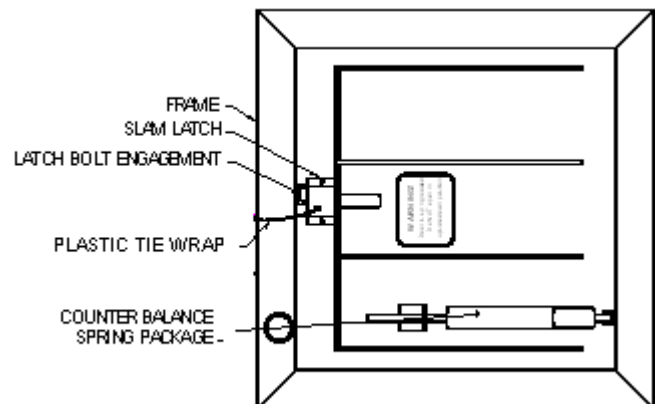

View from Underside

Storage Prior to Installation:

Do not store floor door outside. If storage is required, insure the floor doors properly covered and stored indoors.

Installation:

1. Special care is required when handling and installing floor doors. Please make sure that all framework and doors are supported during transport and installation to insure against bending or racking of the floor door.

2. Floor doors for existing openings are provided with 3/8" diameter holes along the frame, as shown.



3. Set the units into position over the desired opening area. The inside opening of the frame is the "opening size" Secure the floor door into the desired area with welding, bolting or other anchorage, making sure not to interfere with the operation of the hatch.

4. For bolt-in installation in concrete, position floor door into existing opening and mark where fastener holes are located on the mounting surface. For concrete, 5/16" anchor bolts are recommended. For wood 5/16" lag bolts are recommended.

5. Operate- open and close the door. Adjust the spring packages with a 3/4 inch open end wrench, if necessary. The springs have an adjustment bolt on the spring rod (near the bottom of the spring housing). The springs may have been adjusted down to remove any undue stress on the frame during transport. Tighten the bolts until the tube is within 1/8 inch of the door bracket. **DO NOT OVER ADJUST.** Over adjusting will cause the spring to "bottom out" when closing the door. If the door does not close all the way, **DO NOT FORCE IT SHUT.** Adjust the springs down (more gap between the tube and door bracket). Try the door again and adjust springs again as necessary.

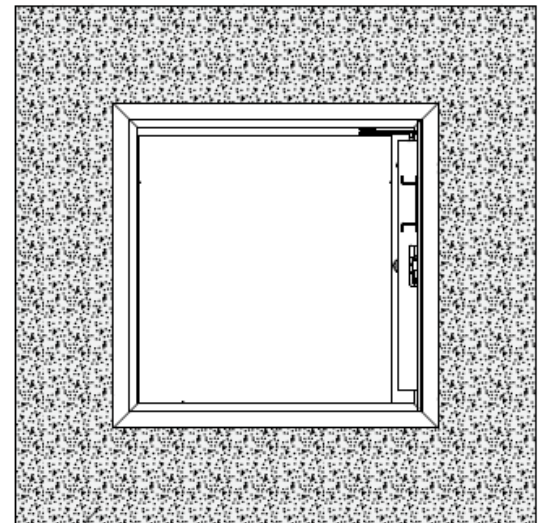

6. To install a spring to the floor door simply insert the top of the spring through the door bracket then swing the bottom of the spring assembly towards the frame into the frame bracket and insert the 1/4-20 bolt through the frame bracket and spring rod and fasten with a 1/4-20 nylon nut.

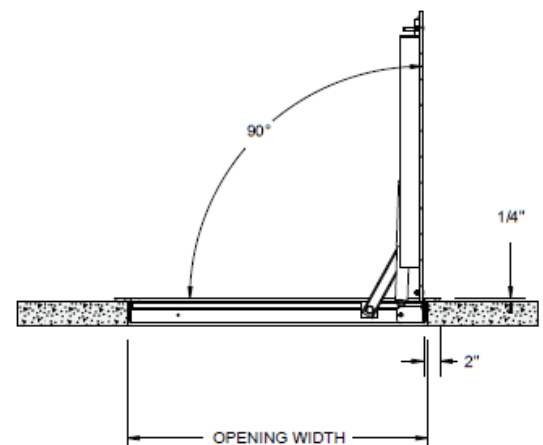



Right to site.

IO&M

Floor Doors, Existing Opening - 08.31.00

Operation

Floor doors are designed and built for years of dependable access. The floor doors are manufactured from steel, aluminum, and or stainless steel. All floor doors come standard with stainless steel hardware components. The basic components for door operation include turn handle latches, compression springs, stainless steel hinges and a locking hold open arm as detailed:

- Latch: Slam latch with interior rotating handle, and exterior L-handle key.
- Drop down lifting handle
- Spring: Compression springs to ensure ease of opening and closing during use.
- Hinge: Stainless Steel hinges
- Hold Open Arm: Locking hold open arm automatically engages and locks when the door fully opens. The hold open arm must be engaged in the locked position to ensure that the door does not close unintentionally. Pull the red vinyl grip handle to unlock and safely close the door.

Maintenance:

-Floor doors should be manually operated once a year to check performance.

-Lubricate moving parts such as springs, hinges, and latches with a silicone spray lube as required to maintain a smooth opening and closing of the door. Do not over grease. Do not use regular lubricating oil as it can attract dust and grit.

-Non-moving parts can be cleaned with a mild soap or dishwashing detergent and water solution.

-Gaskets can be cleaned with a clean, damp, lint-free cloth. Do not apply mineral oils, vinyl dressings, or other lubricants to the gasket as they can cause the gasket to break down over time.

-If any questions arise during the operation or maintenance of the products, please feel free to call our toll-free number for assistance, 1-800-547-2635.