

9300 73rd Ave N.
Brooklyn Park, MN 55428

Toll-Free: 800-547-2635
Fax 800-317-8770



Right to site.

Direct Phone: 763-488-9200
Direct Fax: 763-488-9201

e-mail: info@nystrom.com
Internet: www.nystrom.com

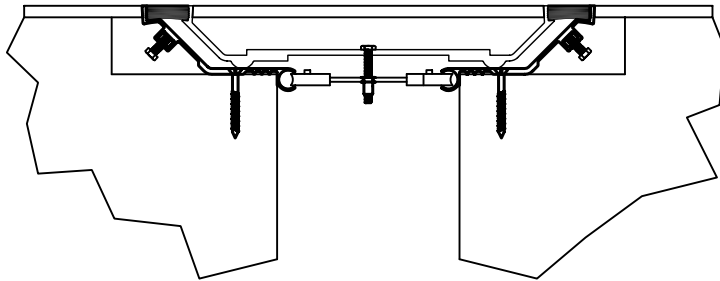

Model EJ-FLP – Flush Condition
See Sheets 1 – 14

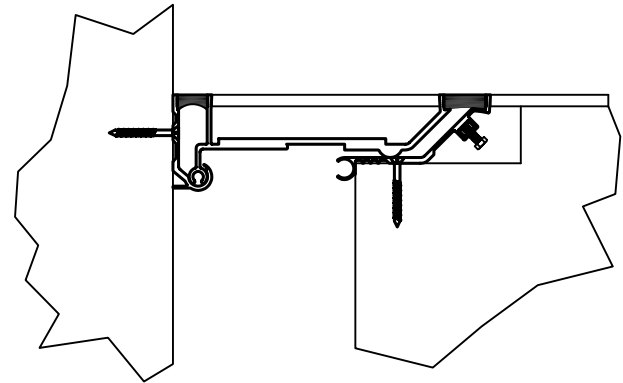

Model EJ-FLP – Corner Condition
See Sheets 15 – 25

Seismic Pan – Professional Series Model(s) EJ-FLP Horizontal Expansion Control System

The following installation procedure is very important and must be fully understood prior to beginning any work. To ensure proper installation and performance of expansion joint system the following actions must be completed by the installing contractor. Failure to do so will affect product warranty.

- 1) Carefully read and understand installation procedure. Contact Technical Service Department for product assistance.
- 2) Inspect all shipments and materials for missing or damaged components and hardware. Contact Customer Service with order number and invoice for prompt assistance.
- 3) Inspect substrate or adjacent construction for acceptance before beginning work. Report unacceptable construction to the project manager for scheduled repair work.

PN: N20184

Standard Components

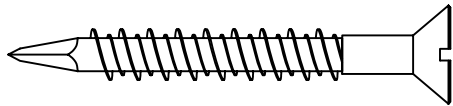

Concrete Threaded Anchor #2764
1/4" x 2-1/4"
Part No. 6526

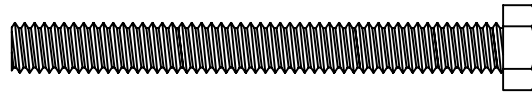

Bolt 1/4" x 2-1/2" HLN
Part No. 4835



Nut 1/4" Zincplated A307
Part No. 7869



Bolt 1/4" x 1" HLN
Part No. 4836

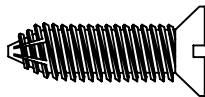

Screw 1/4" x 1" FTPN
Part No. 5634

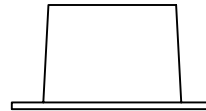

CapPlug W8 Red Plastic
Part No. 4337

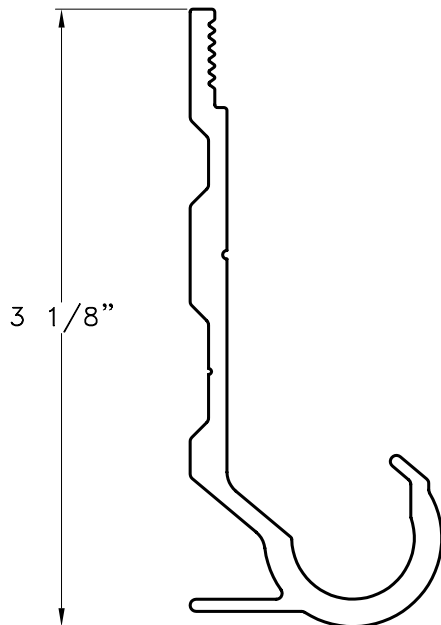

Wall Mount
Part No. 19610

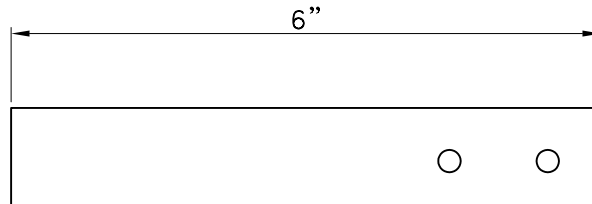

Butt Splice Connector
Part No. 14050

Concrete Filler
Part No. 1020550
Not supplied with expansion
joint system – Purchased separately

Components shown below vary in size depending on model of system

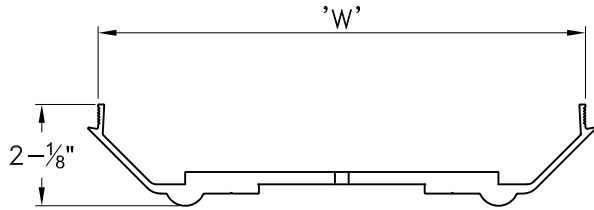

Aluminum Pan

Model #	Part #	'W' dim.
EJ-FLP-400	19624	9.917"
EJ-FLP-600	19625	11.917"
EJ-FLP-800	19626	15.917"
EJ-FLP-1000	19627	17.917"
EJ-FLP-1200	19628	20.917"
EJ-FLP-1600	19617	26.917"
EJ-FLP-1800	19618	31.917"

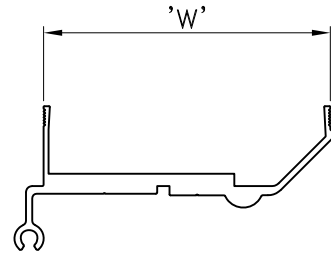

Aluminum Pan

Model #	Part #	'W' dim.
EJ-FLP-400W	19630	5.835"
EJ-FLP-600W	19631	7.835"
EJ-FLP-800W	19632	10.835"
EJ-FLP-1000W	19633	12.835"
EJ-FLP-1200W	19634	15.835"
EJ-FLP-1600W	19635	20.835"
EJ-FLP-1800W	19636	23.835"

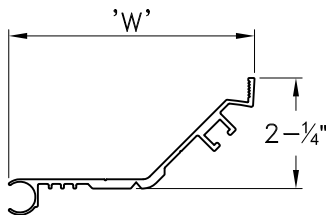

Aluminum Edge Frame

Model #	Part #	'W' dim.
EJ-FLP-400/600	19612	5.00"
EJ-FLP-800/1000	19609	6.00"
EJ-FLP-1200	19606	6.50"
EJ-FLP-1600	19607	7.50"
EJ-FLP-1800	19608	9.00"

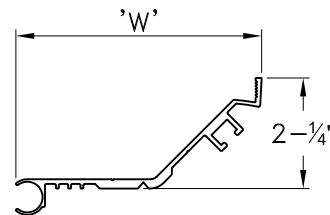

Aluminum Edge Frame

Model #	Part #	'W' dim.
EJ-FLP-400W/600W	19612	5.00"
EJ-FLP-800W/1000W	19609	6.00"
EJ-FLP-1200W	19606	6.50"
EJ-FLP-1600W	19607	7.50"
EJ-FLP-1800W	19608	9.00"

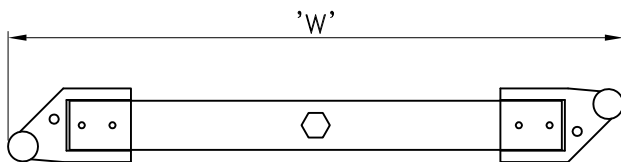

Seismic Centering Bar

Model #	Part #	'W' dim.
EJ-FLP-400	15642	7.375"
EJ-FLP-600	15643	12.375"
EJ-FLP-800/1000	15630	18.375"
EJ-FLP-1200	15631	22.375"
EJ-FLP-1600	15603	26.375"
EJ-FLP-1800	15604	38.375"

Flush Condition

Corner Condition

Installation procedure for flush condition

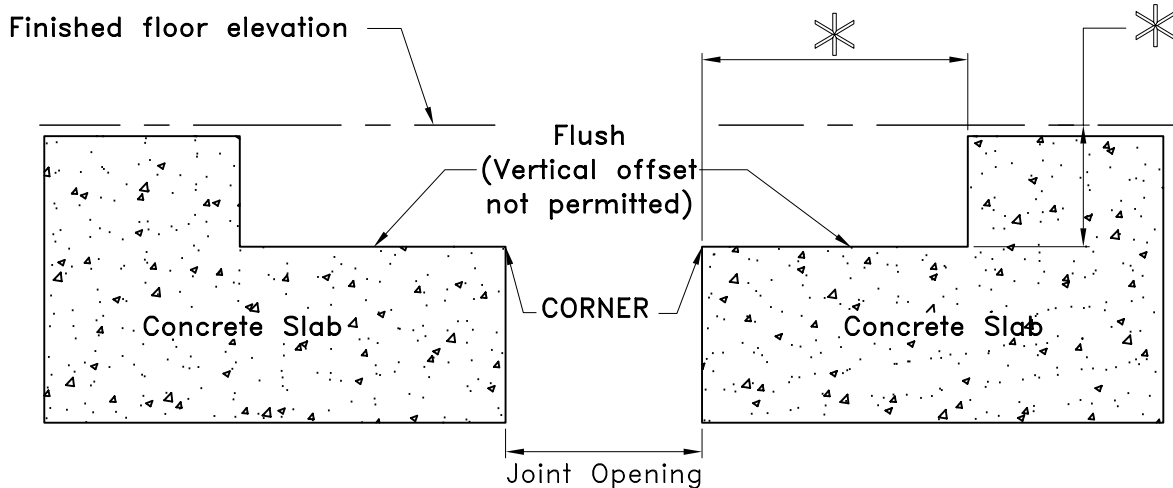

1

Prior to beginning work, installer shall inspect opposing concrete slabs, corners and blockouts for acceptability. For repair (if required) refer to step 2, also, measure joint opening for proper size as called for on shop drawings or Cad detail.
* See Shop drawings or Cad detail for specific blockout information.

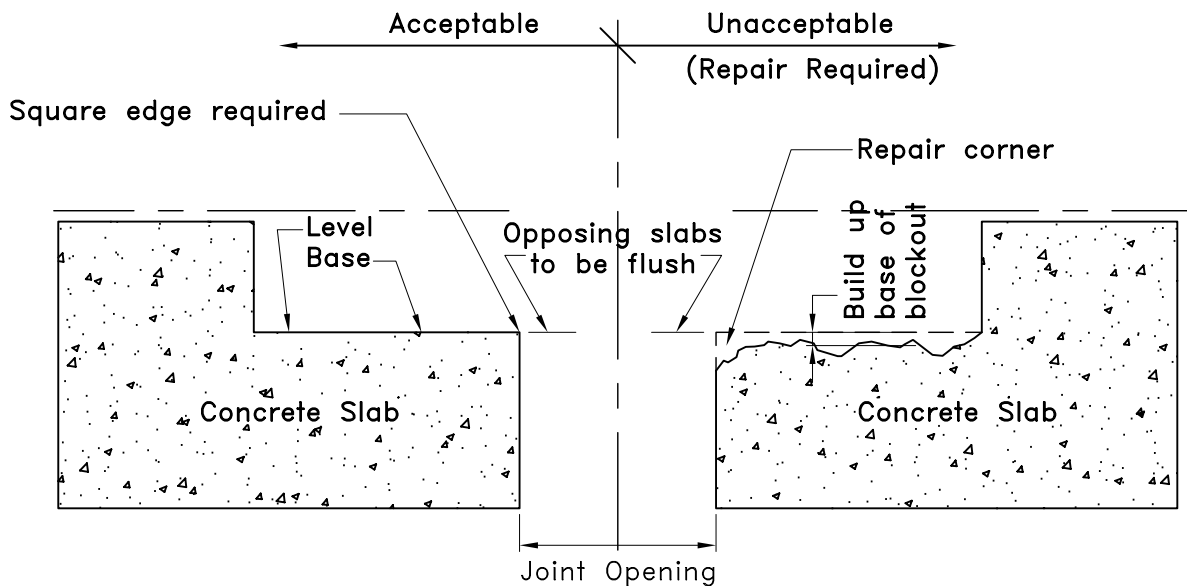

2

Repair corner of concrete slab and blockout base following manufacturers written instructions.

Figure 3a.1

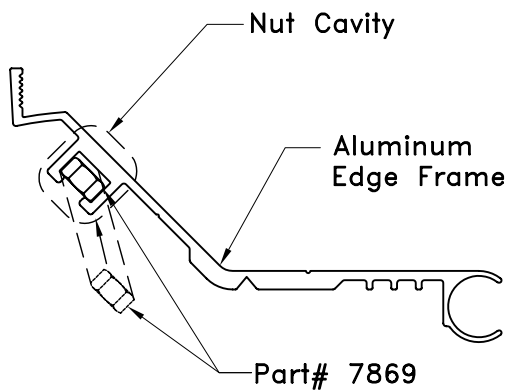
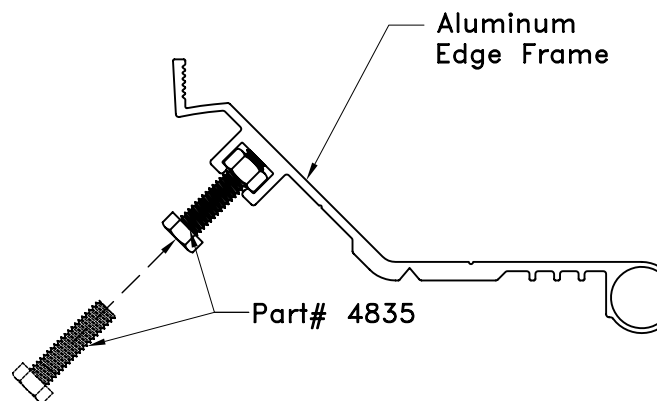

Figure 3a.2



3a

Figure 3a.1 – Insert (4) ZINC PLATED NUTS (Part # 7869) into NUT CAVITY of ALUMINUM EDGE FRAME.

Figure 3a.2 – Thread Bolt 1/4" x 2-1/2" HLN (Part # 7869) into each ZINC PLATED NUT, spacing at 36" on center (starting 6" from either end). Tighten until bolts are secure.

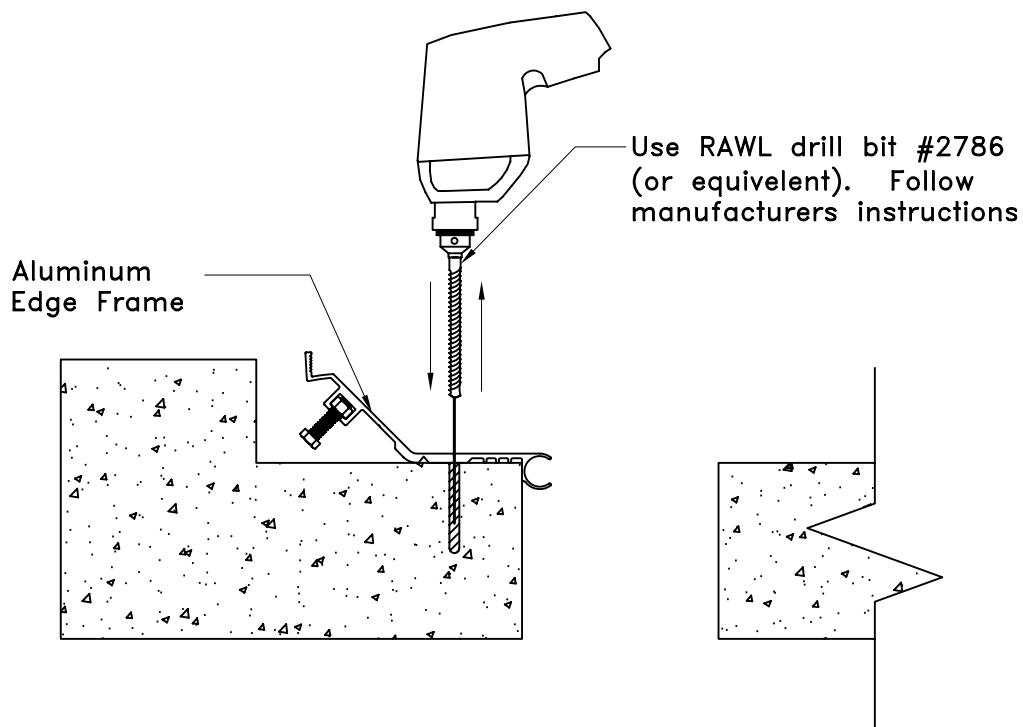

3b

Utilizing pre-drilled holes in Aluminum edge frame assembly as a template, drill pilot holes using a 3/16" TAPPER Masonry drill Bit. Use two 5 foot Aluminum Edge frame sections (1 on each side of joint opening) when starting a run of Seismic Pan. See step 6.

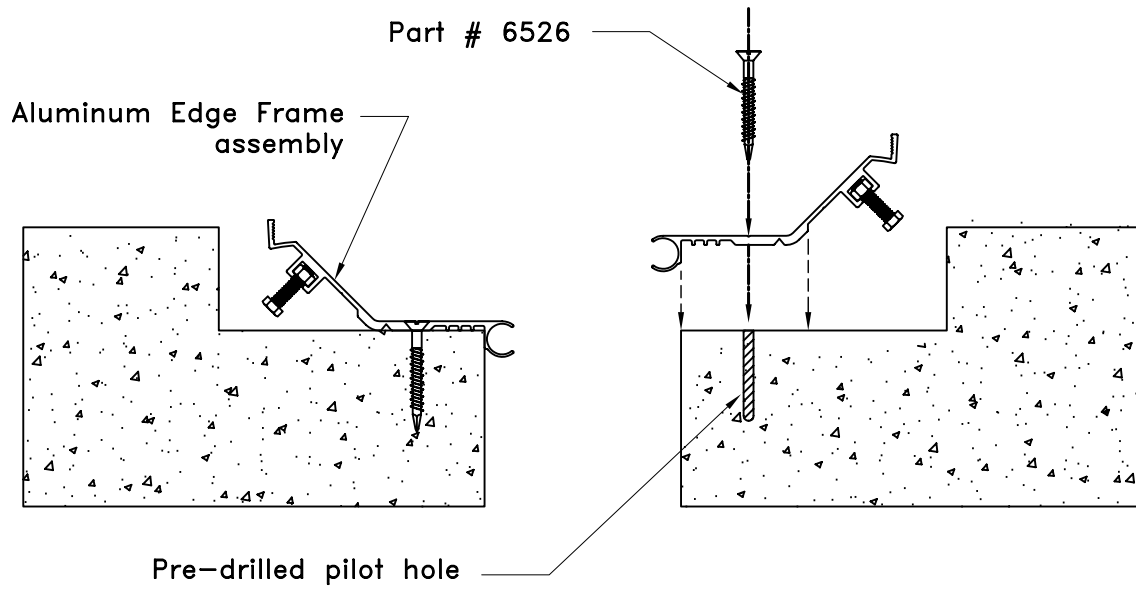

3c

Fasten Aluminum Edge Frame Assembly securely using Threaded Anhc^or Rawl Tapper #2764 1/4" x 2-1/4" (Part No. 6526)

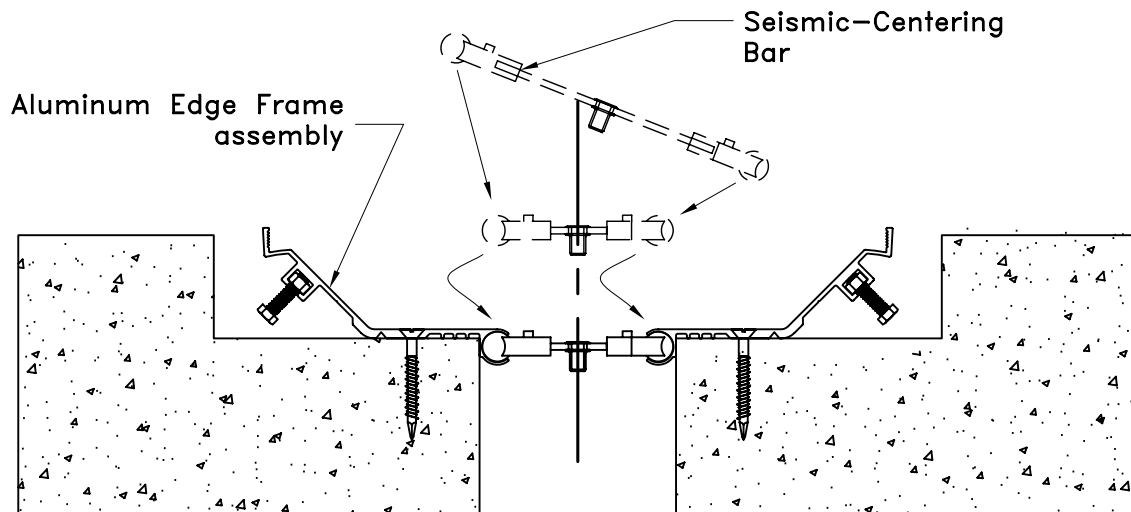

4

Insert Seismic-centering bars into circular aluminum cavity as work progresses from step 3c. Space bars at 18" o.c. See plan next page.

All Seismic-centering bars must be oriented in the same direction. Side of the Seismic-centering bar labeled "Top" must be facing UP.

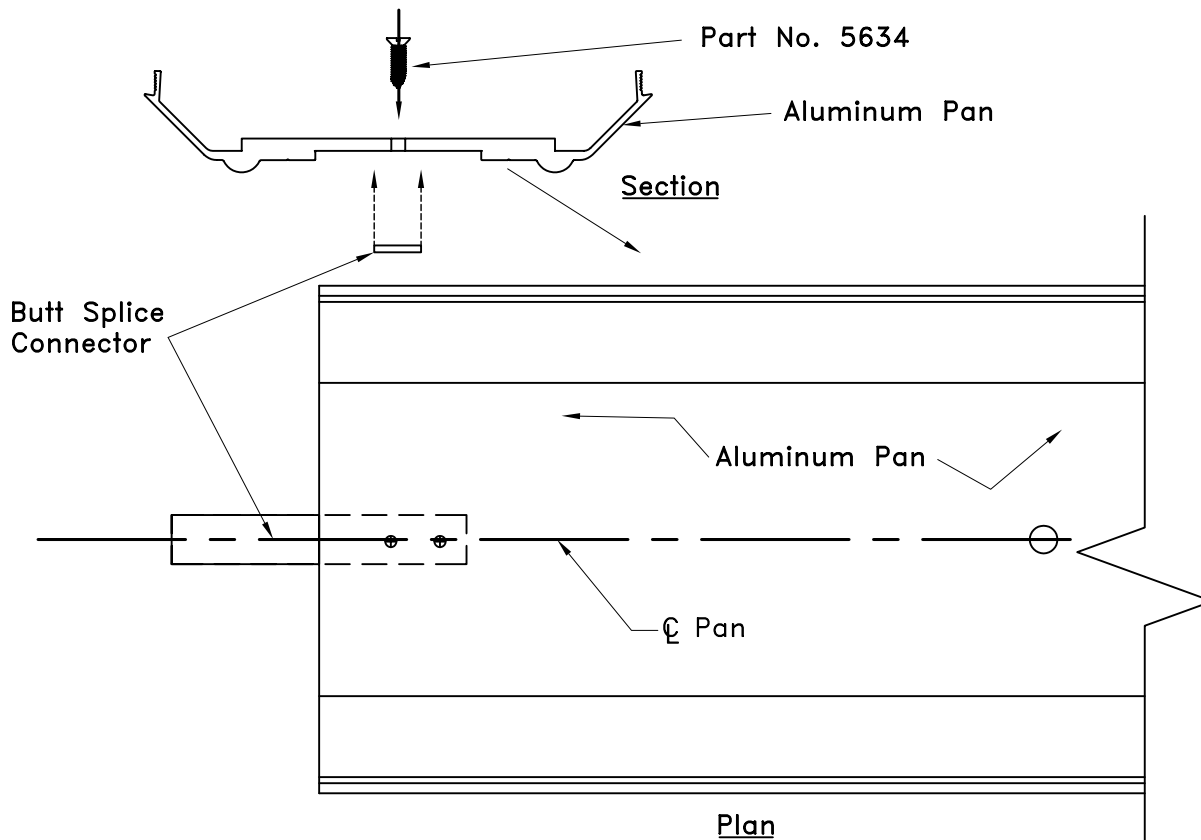
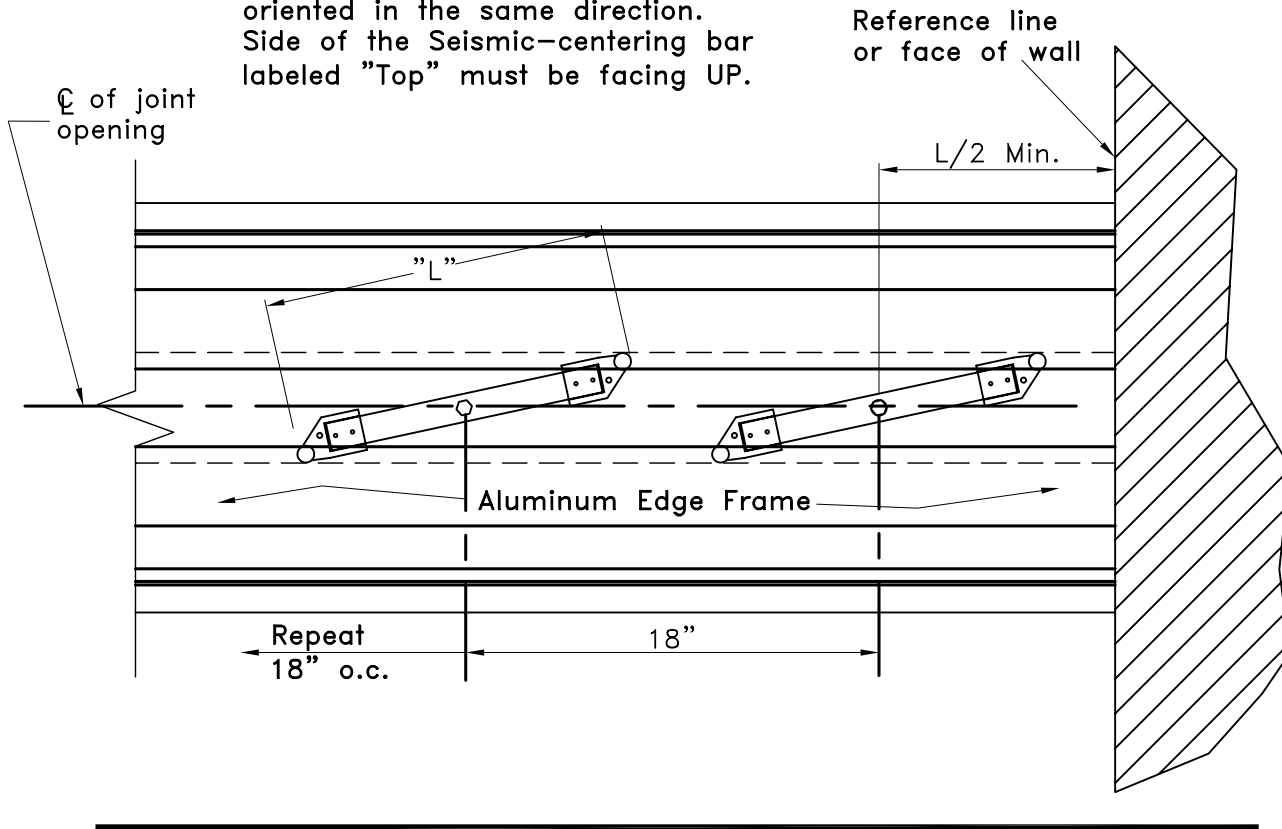

5

After aluminum edge frames and Seismic-centering bars are installed, start adding butt splice connectors to one end of each aluminum pan using factory holes provided and part no. 5634 (Screw 1/4" x 1" FTPN)

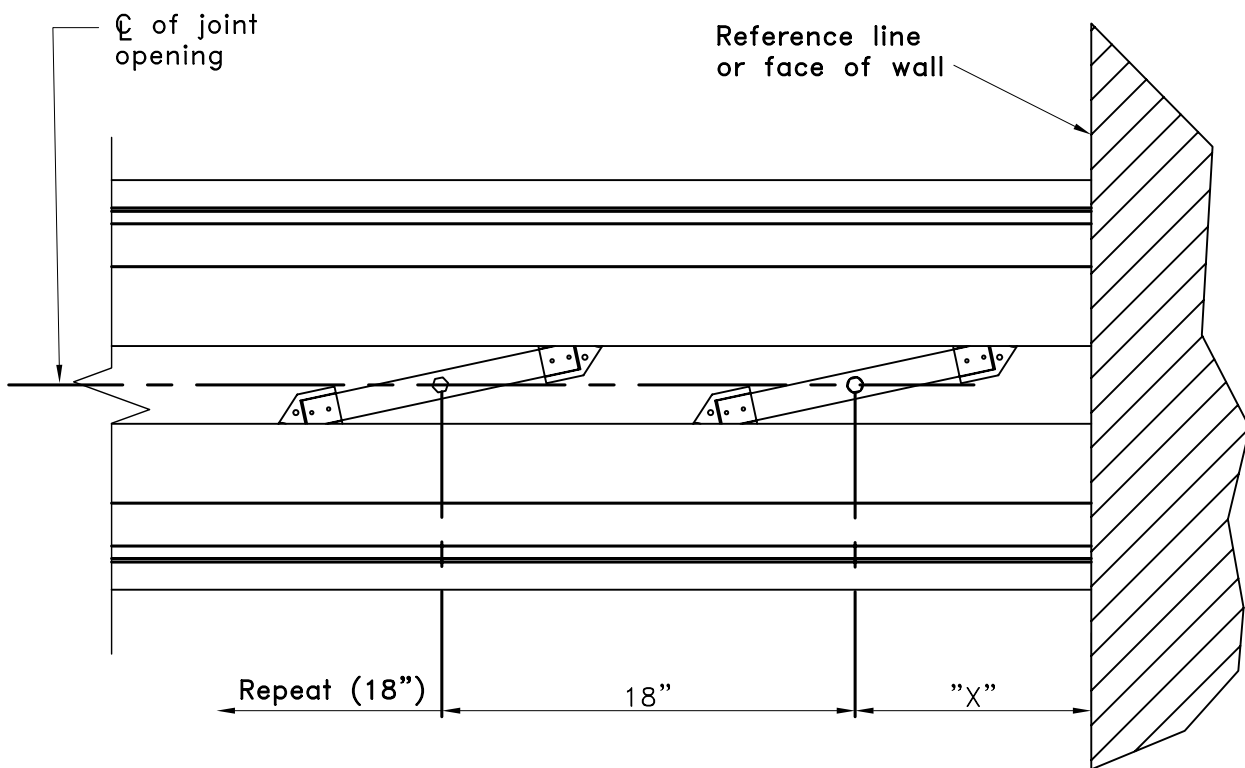
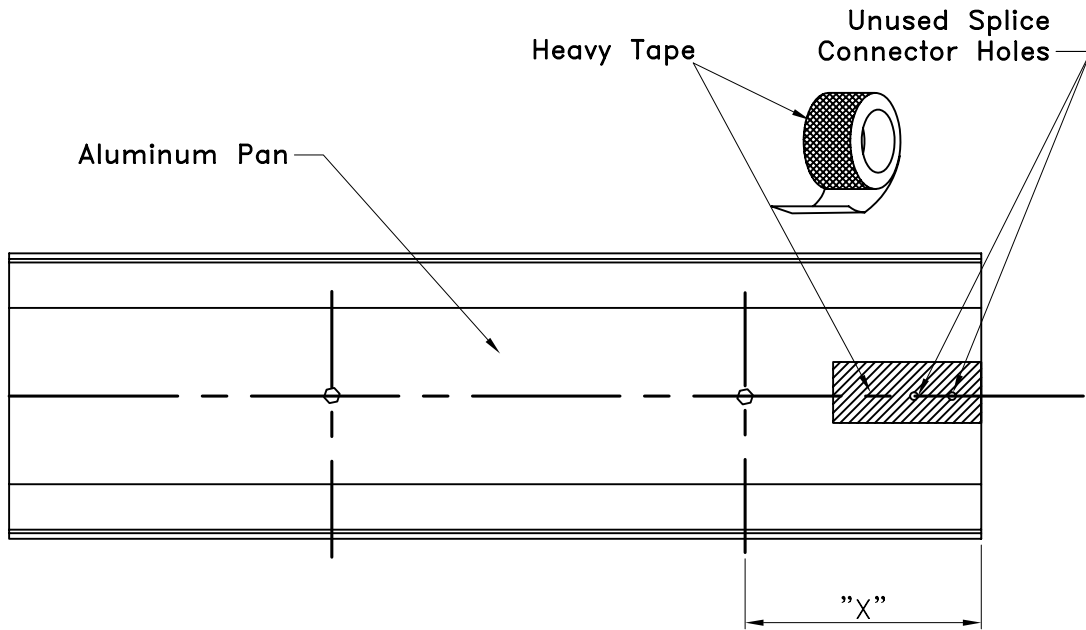

6

Use Heavy Tape to cover un-used splice connector holes (this will be at the first aluminum pan to be installed against the wall). Take Measurement "X" from Aluminum Pan and align first self-centering bar to this dimension as shown. This step is to double check for accuracy before installing the Aluminum Pan

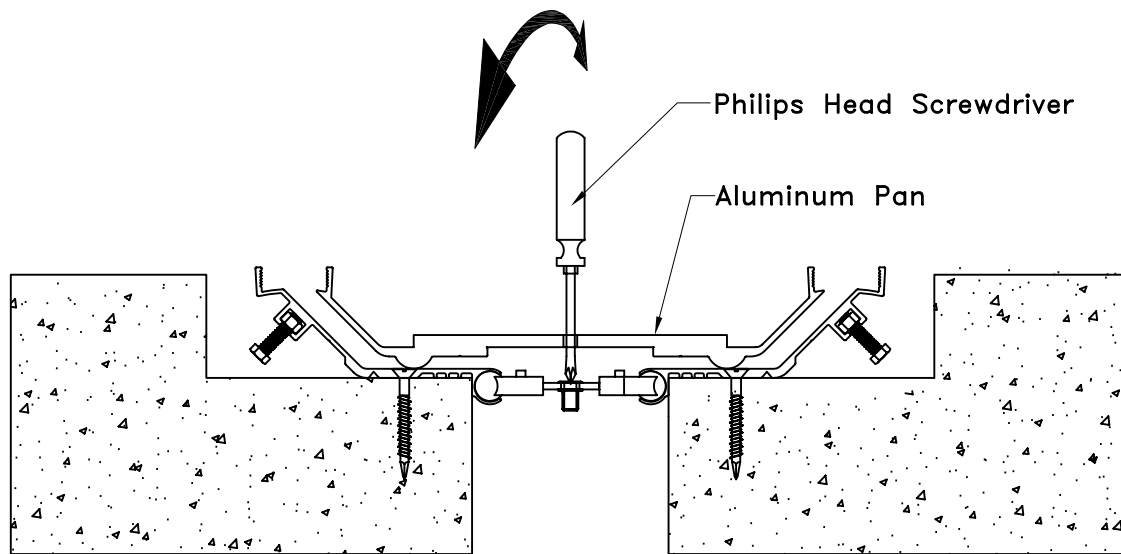
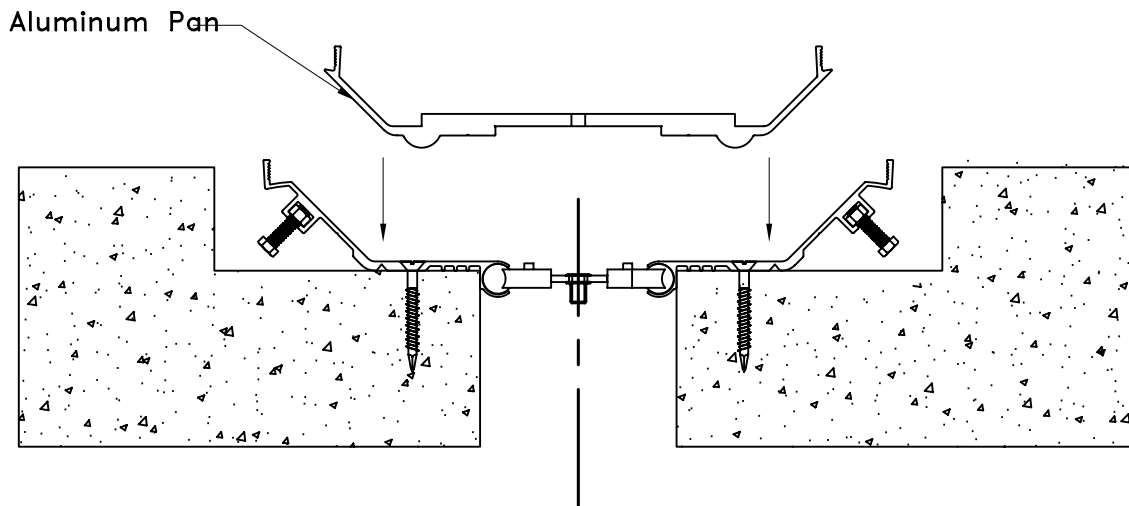

- 7 Center the Aluminum Pan on joint opening while keeping end of pan snug with wall / reference line. Use philips head screwdriver to fine-tune alignment of seismic-centering bars to associated pre-drilled holes in Aluminum Pan.

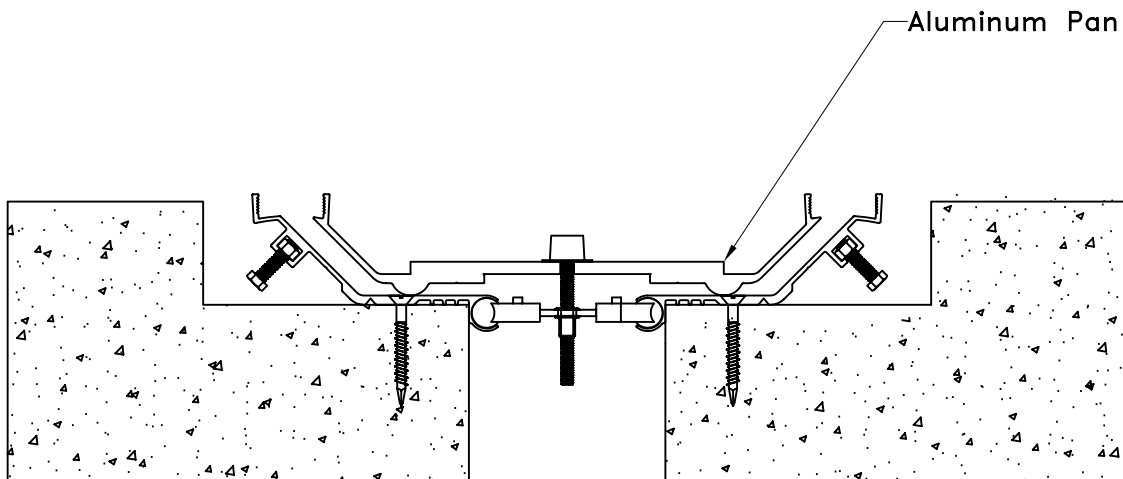
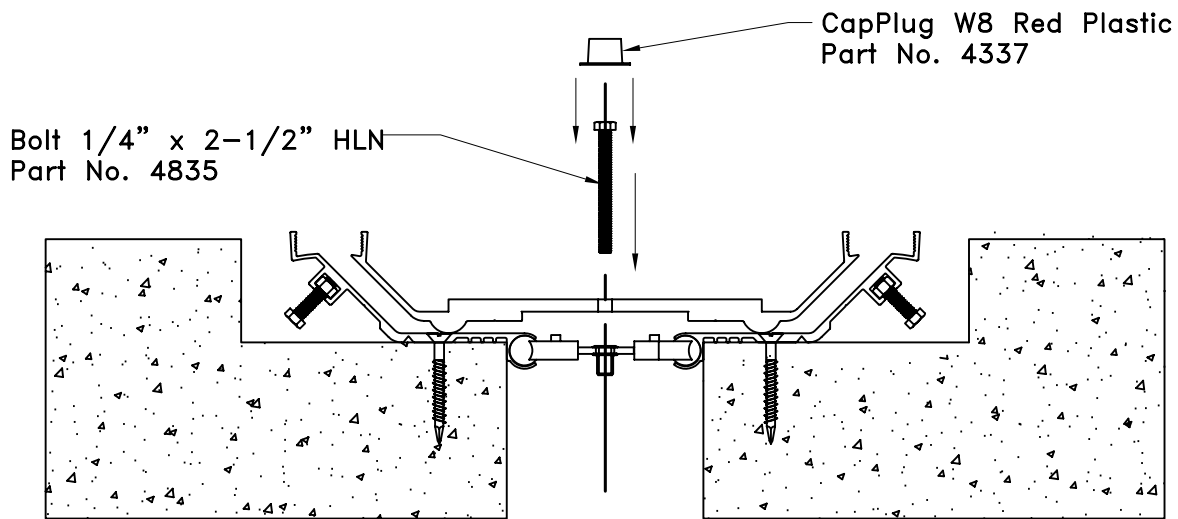

8 Insert Part No. 4835 through pre-drilled holes in Aluminum Pan and seismic-centering bars and tighten to _____ inch-lbs. Cover bolt heads with CapPlugs (Part no. 4337).

Note:

-Installation Tip: Calibrate battery operated drill / driver to proper inch-lb setting. Periodically inspect for proper torque utilizing "clicker" wrench.

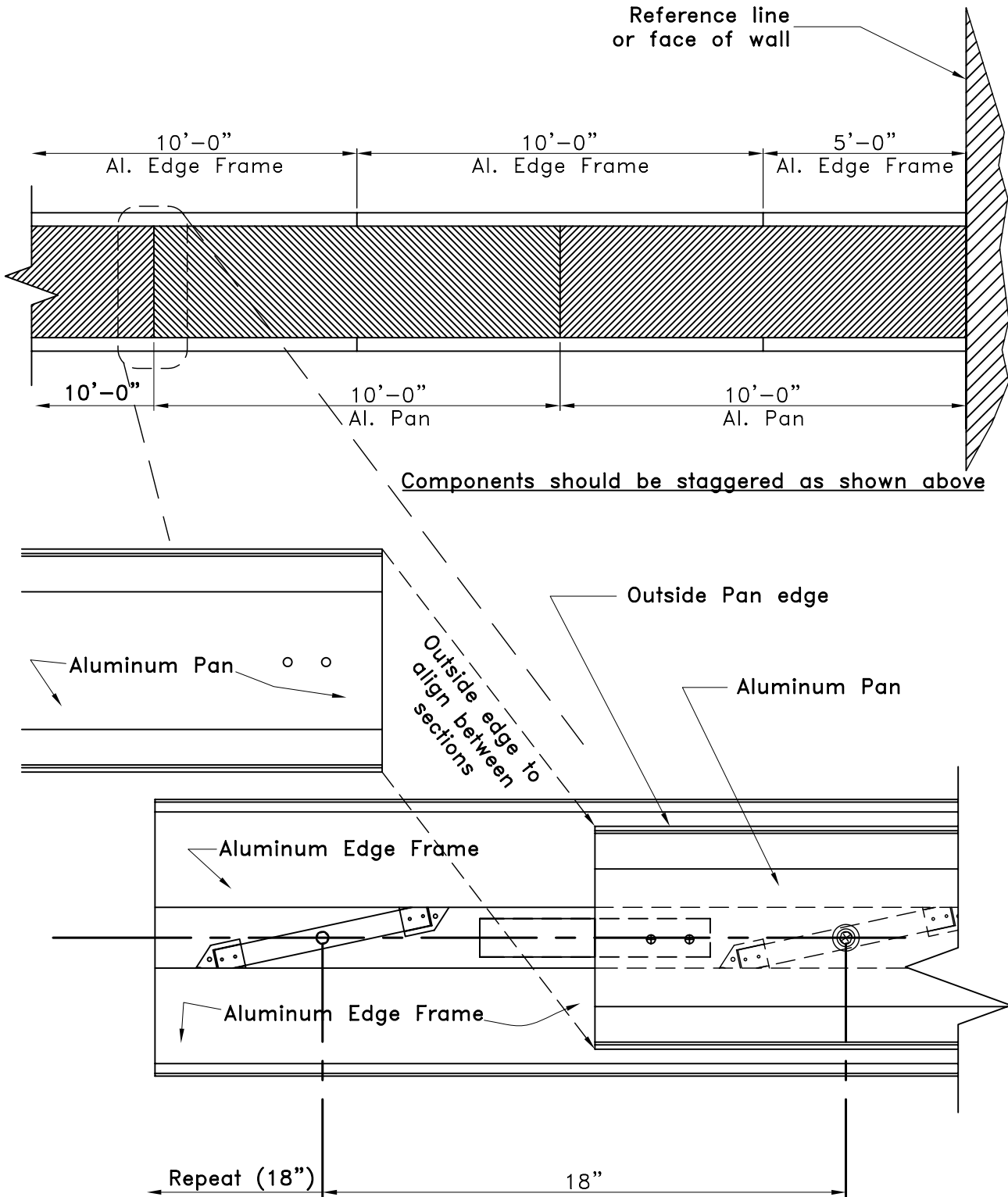

9 Repeat steps 5, 6, & 7 to align seismic-centering bars for next section of Aluminum Pan. Be sure to start threading seismic-centering bars for this section (do not completely tighten seismic-centering bars (as noted in step 8) until Step 10 is complete). Ensure Aluminum pan sections butt tightly together and that the outside edges align from section to section.

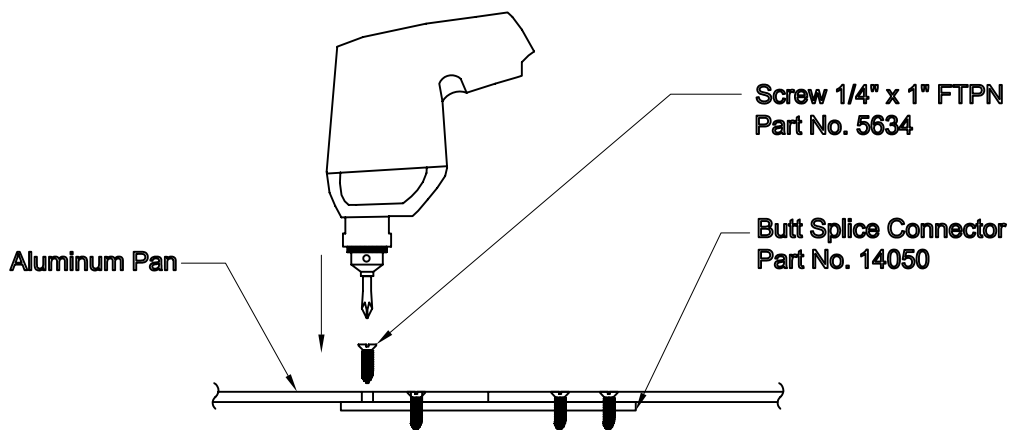
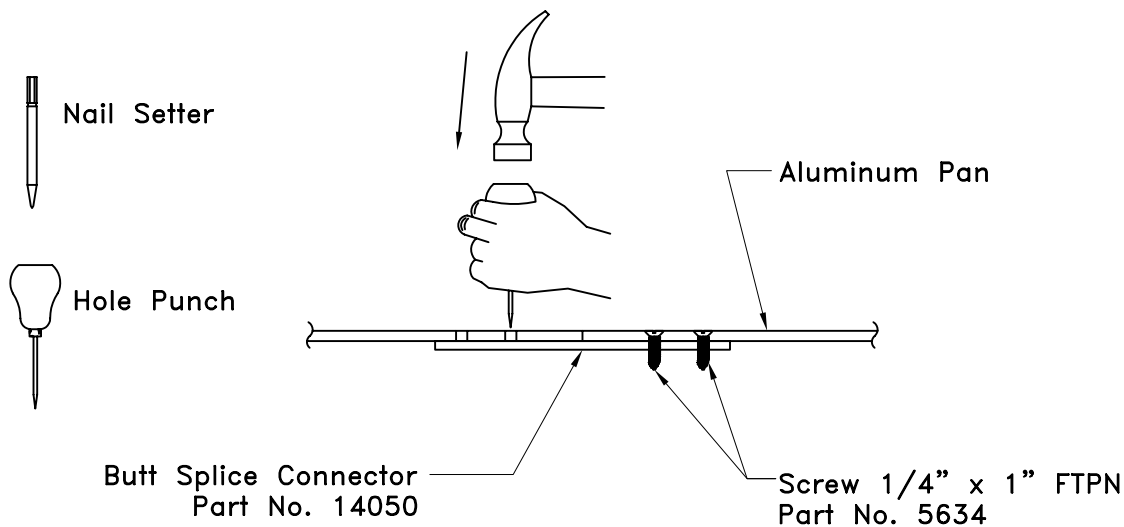
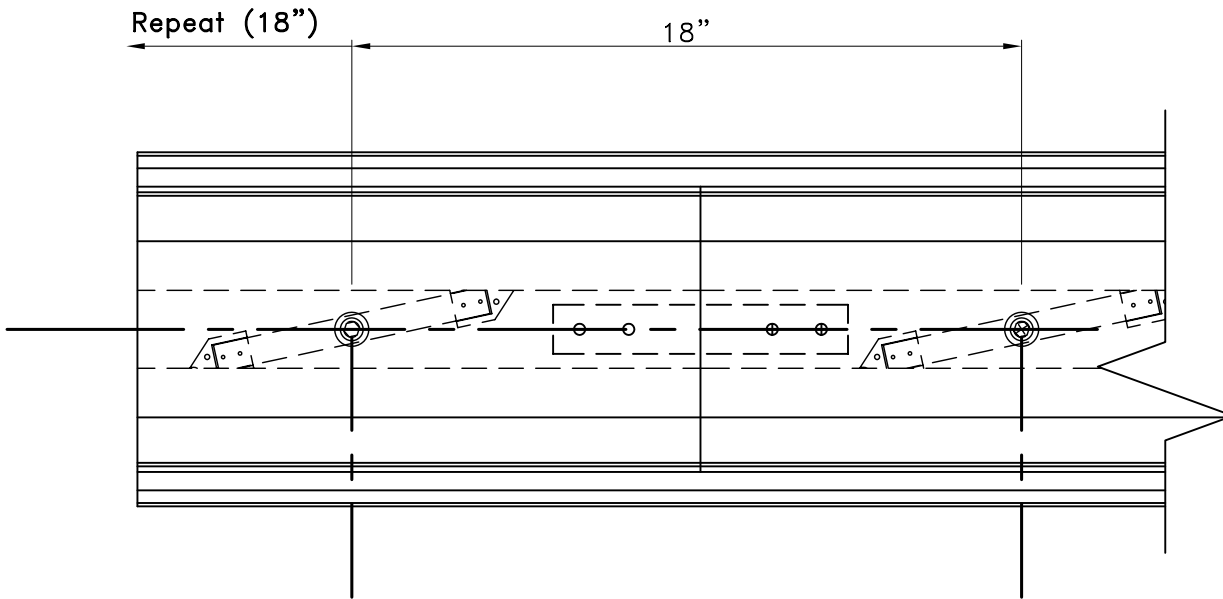

10 Using the splice connector holes in the Aluminum Pan as a guide, firmly tap in guide marks into the aluminum splice connector below utilizing either a nail setter or hole punch. Pre-drill $3/16$ " dia. pilot hole in connector. Use self tapping screws (Part No. 5634) to complete splicing of pan systems together. Tighten seismic-centering bar bolts in newly spliced Aluminum Pan Section.

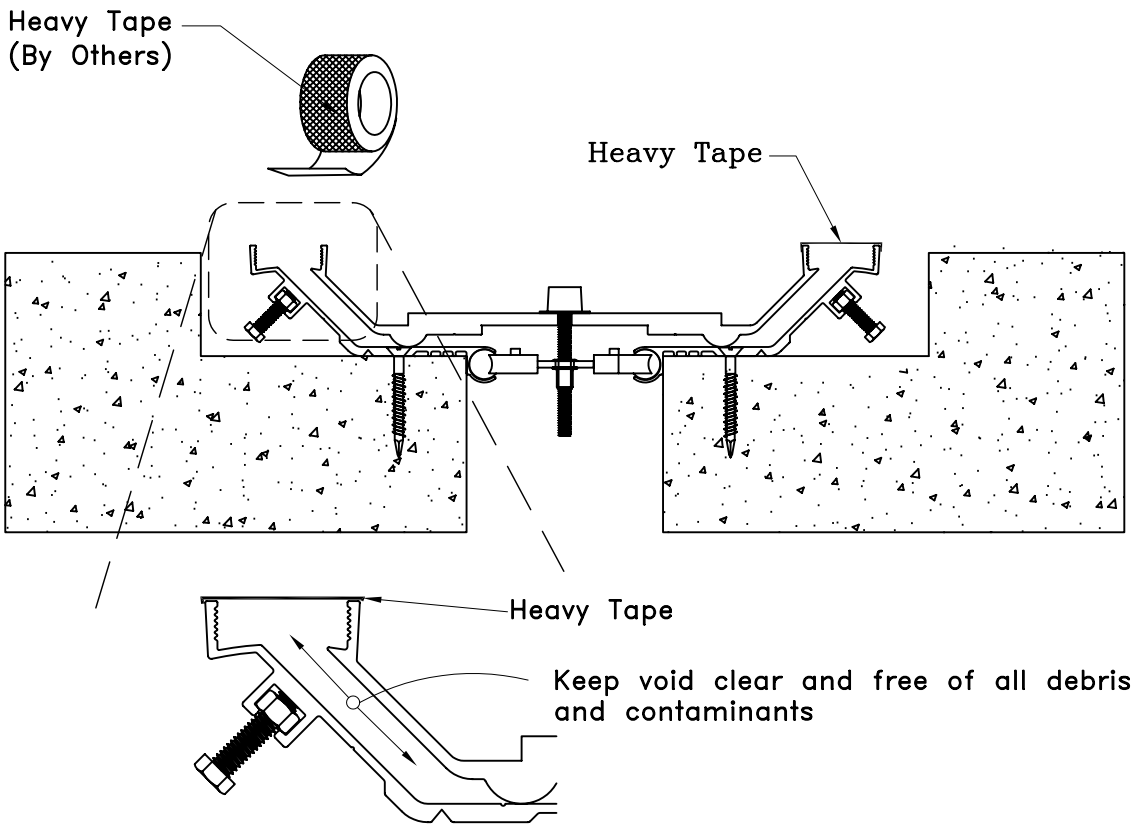

11 Use heavy tape continuously to protect joint opening through the next final steps.

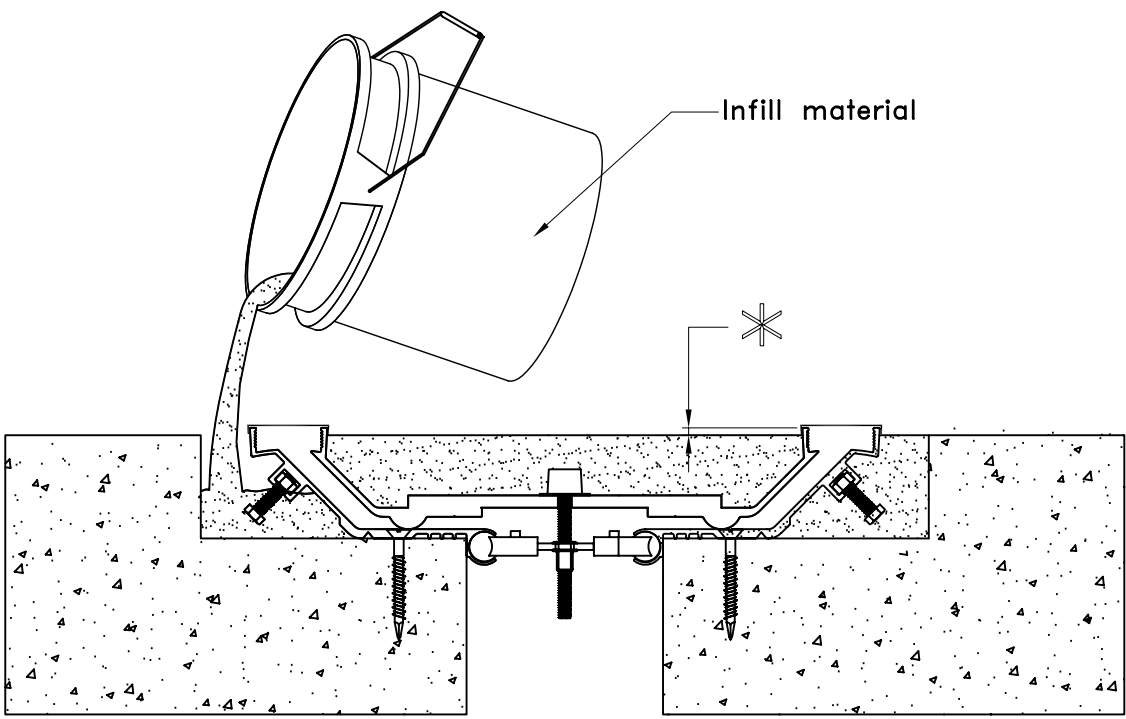

12 Pour infill material into blockout voids and Pan cavity. *Warning! Leave required recess for finish floor finish material thickness and proper placement

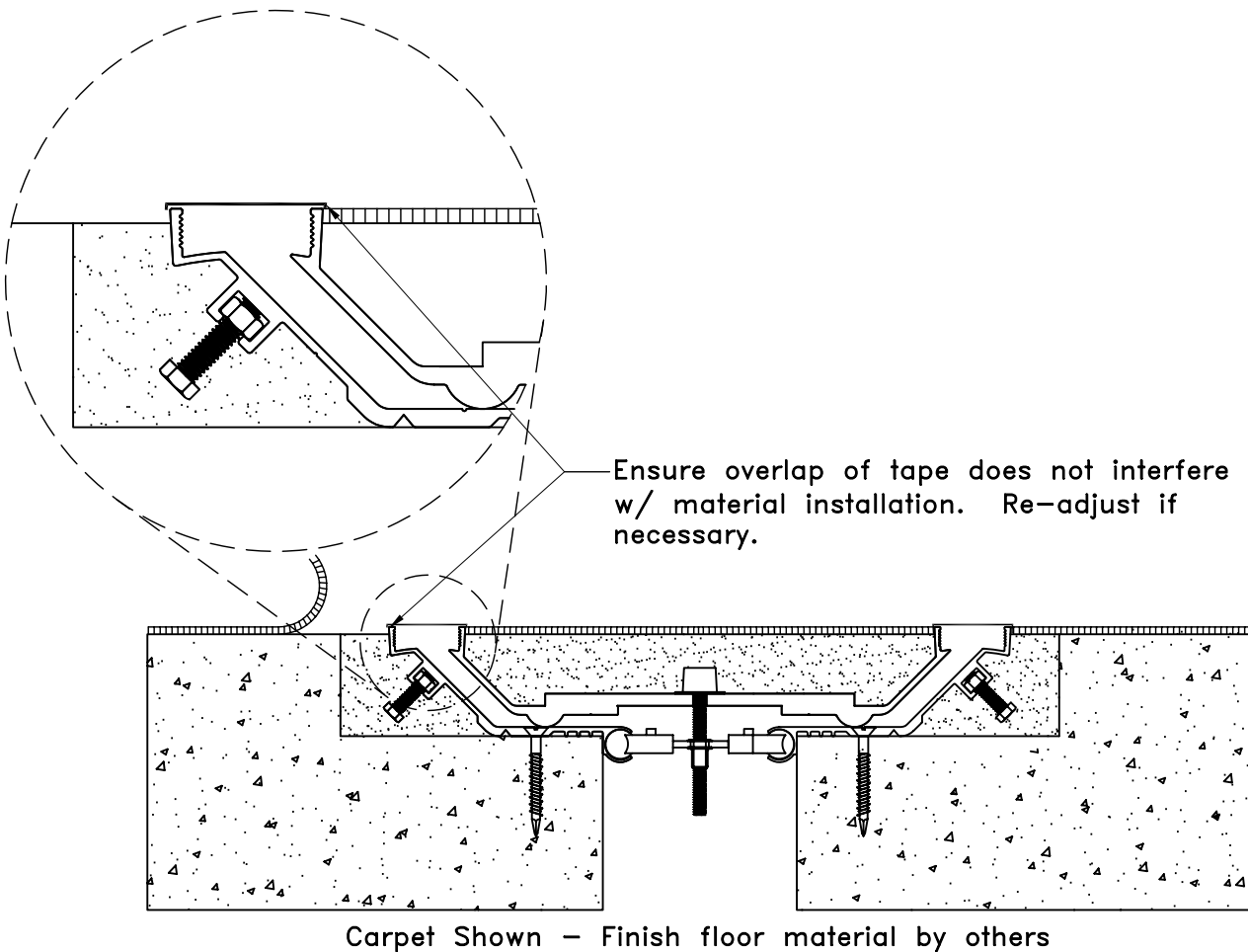

13 Install finished floor material. Be sure to keep joint opening protected (See Step 11)

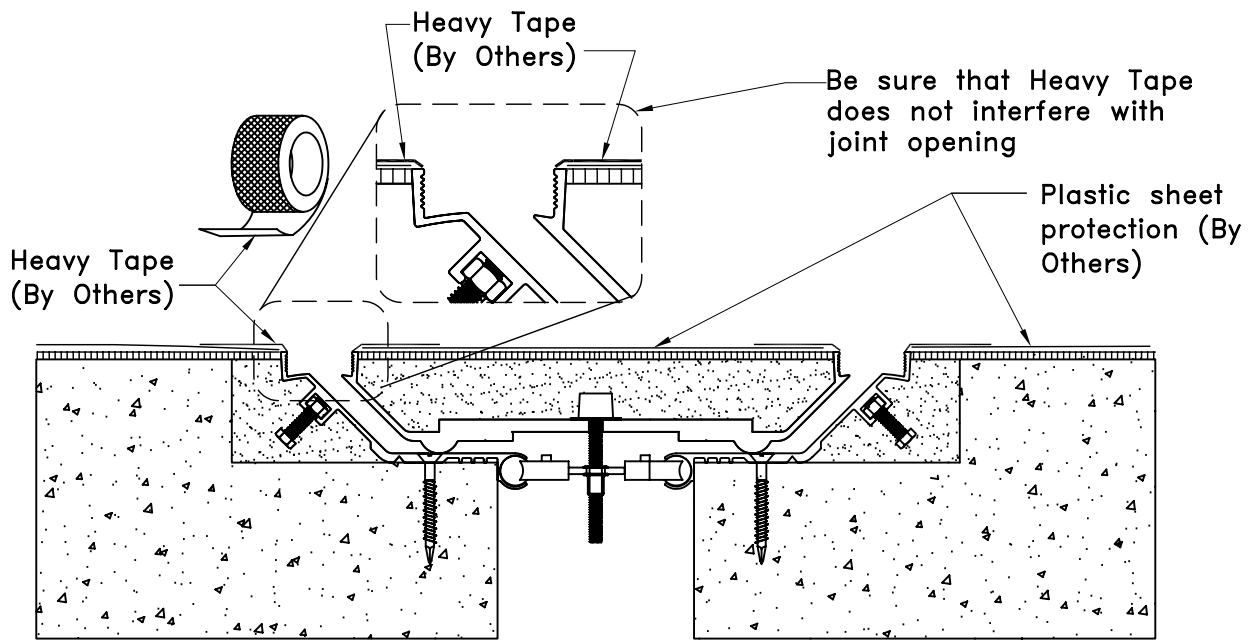

14 Remove Heavy Tape from joint opening. Protect surrounding finish floor material using Heavy Tape and Heavy Gauge Plastic Sheeting

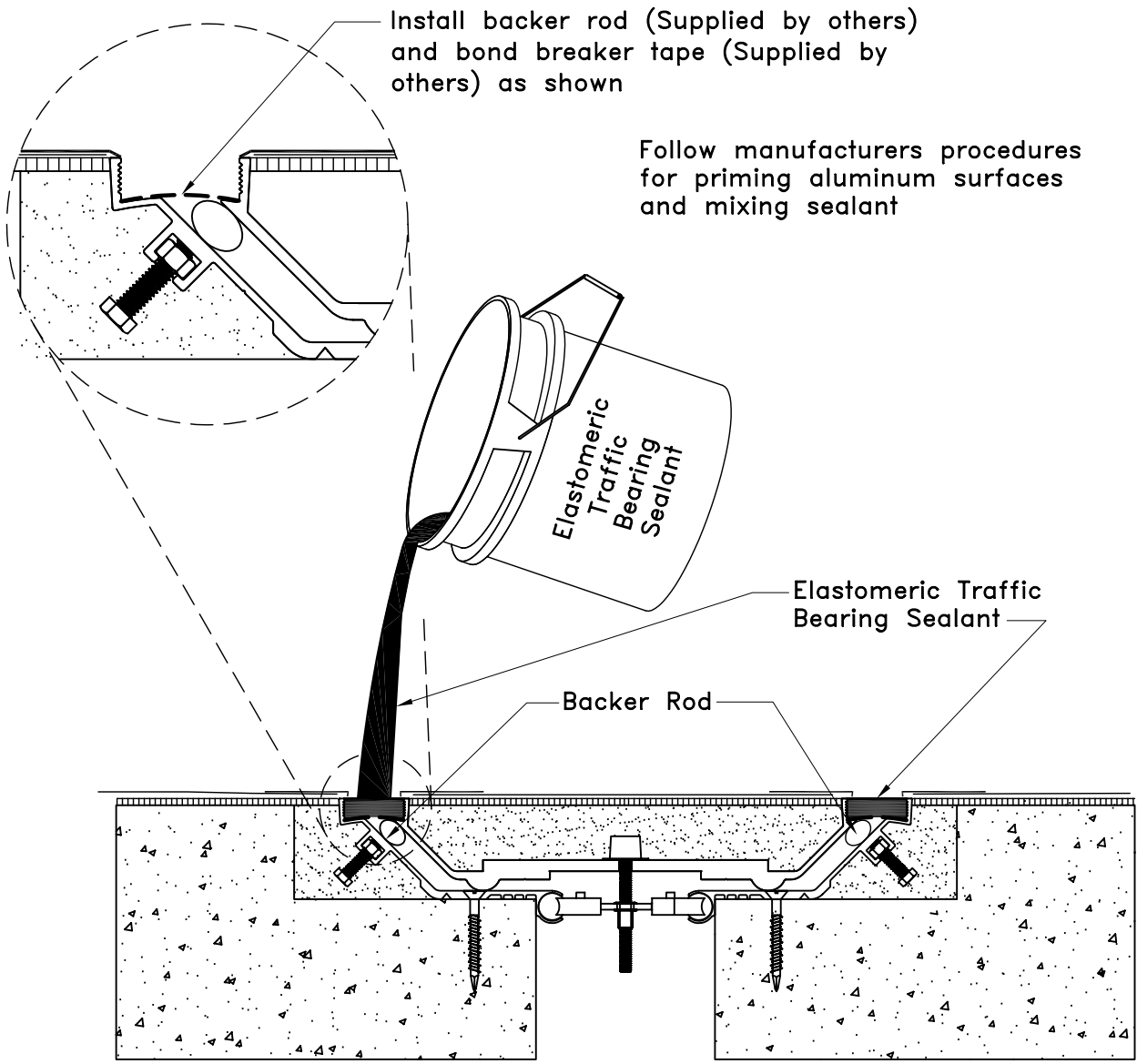

15 Install Backer Rod, Bond Breaker Tape (Supplied by others) & Sealant (Supplied by others).

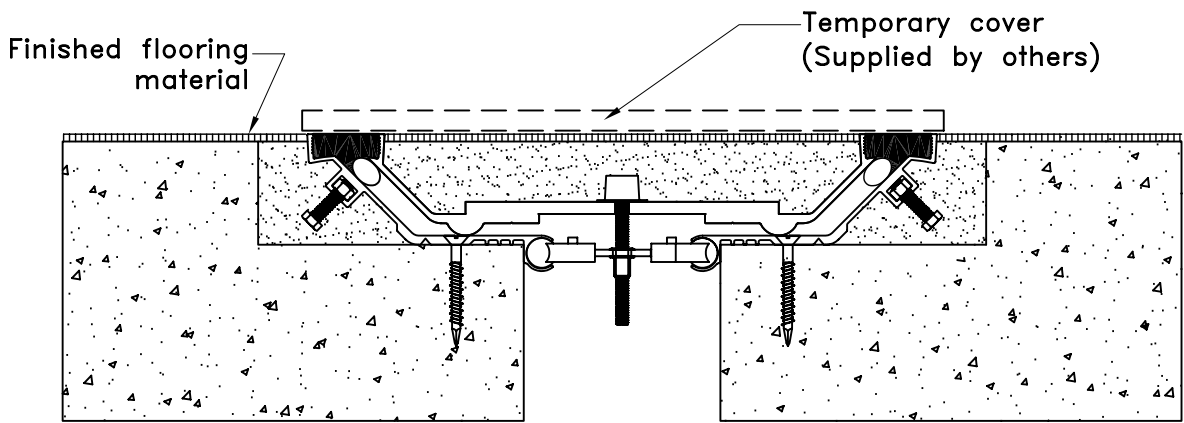

16 Installing contractor shell cover and protect the finished expansion joint assembly from damage during installation of finish floor materials. The expansion joint assembly is a finished product. Damage to expansion joint finishes and components are excluded from warranty

Installation procedure for corner condition

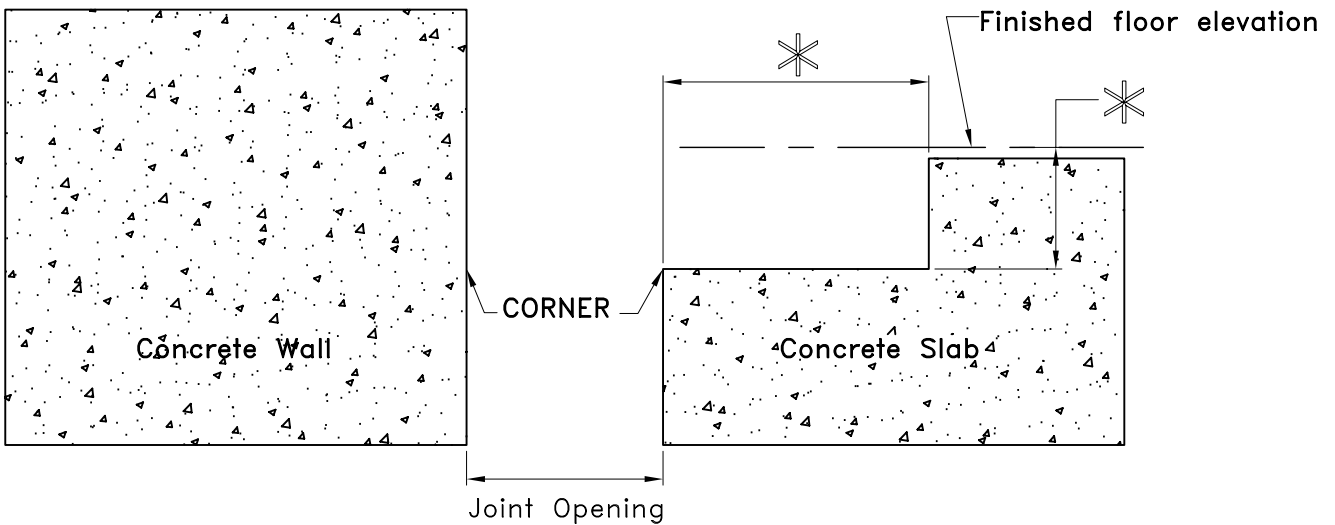

1

Prior to beginning work, installer shall inspect opposing concrete slabs, corners and blockouts for acceptability. For repair (if required) refer to step 2, also, measure joint opening for proper size as called for on shop drawings or Cad detail.

* See Shop drawings or Cad detail for specific blockout information.

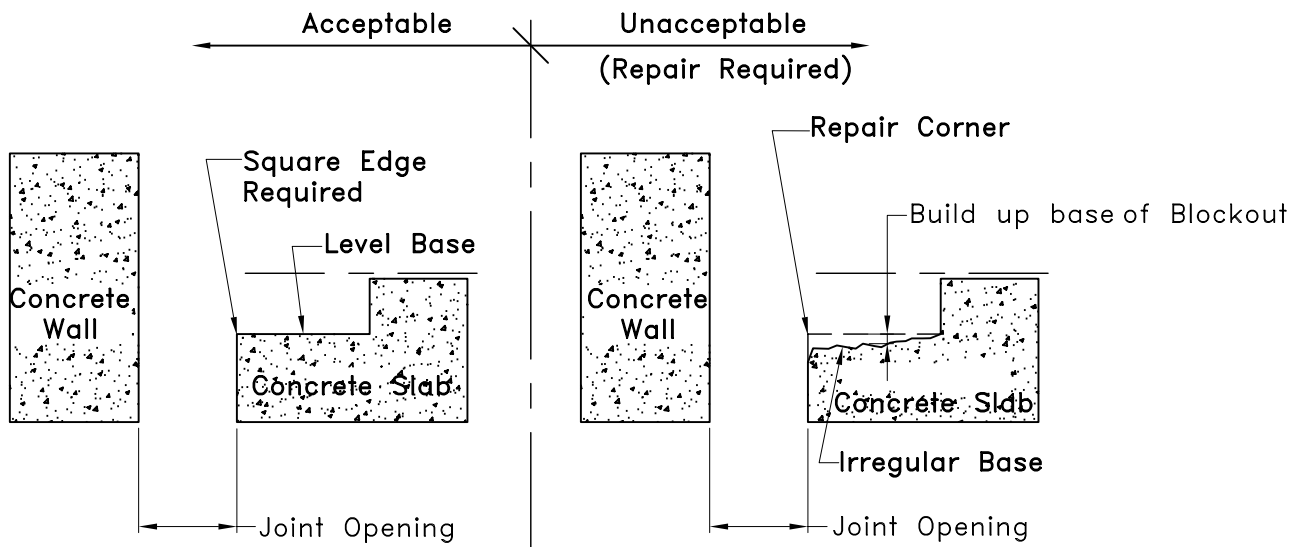

2

Repair corner of concrete slab and blockout base following manufacturers written instructions.

Figure 3a.1

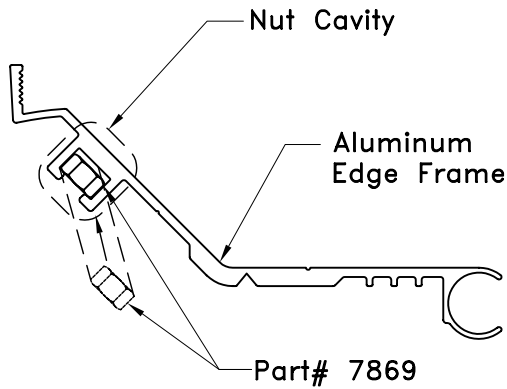
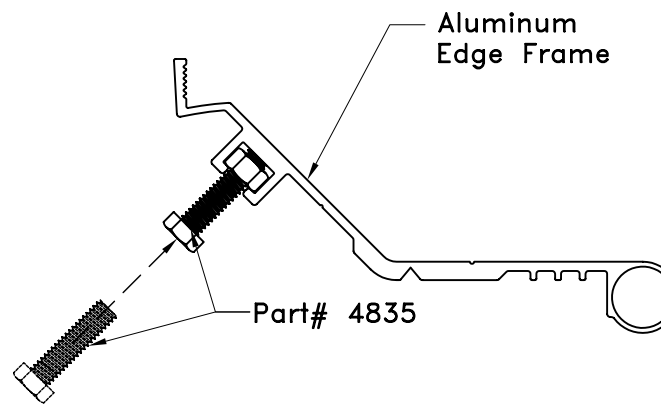

Figure 3a.2



3a

Figure 3a.1 – Insert (4) ZINC PLATED NUTS (Part # 7869) into NUT CAVITY of ALUMINUM EDGE FRAME.

Figure 3a.2 – Thread Bolt 1/4" x 2-1/2" HLN (Part # 7869) into each ZINC PLATED NUT, spacing at 36" on center (starting 6" from either end). Tighten until bolts are secure.

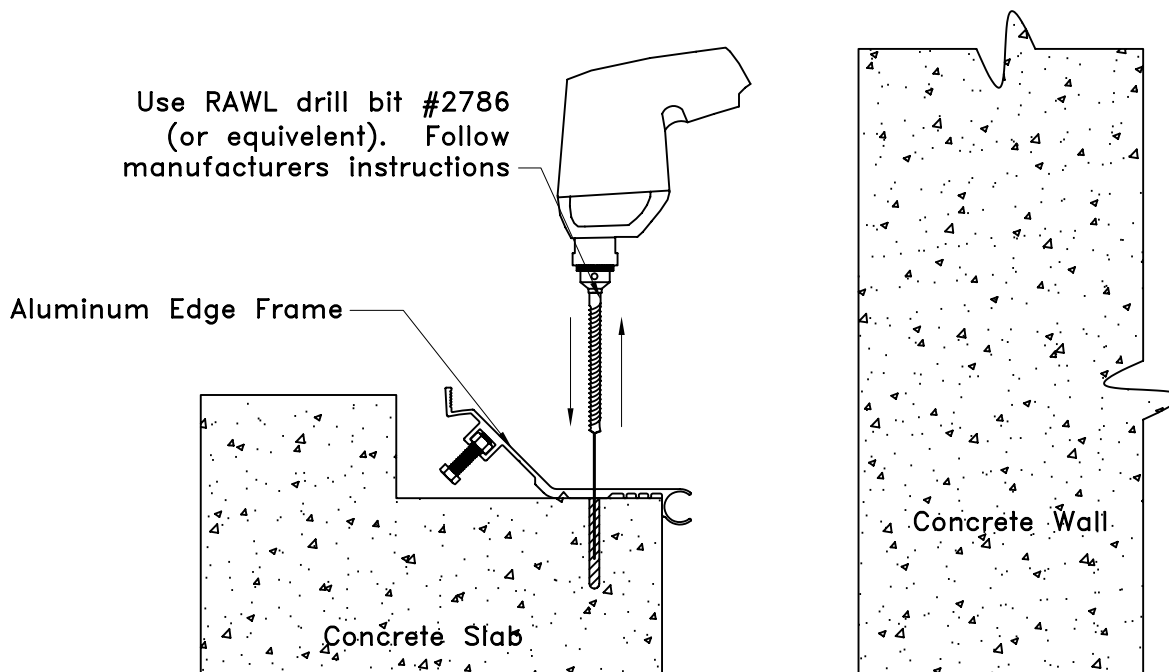

3b

Utilizing pre-drilled holes in Aluminum edge frame assembly as a template, drill pilot holes using a 3/16" TAPPER Masonry drill Bit. Use two 5 foot Aluminum Edge frame sections (1 on each side of joint opening) when starting a run of Wabob Seismic Pan. See step 6.

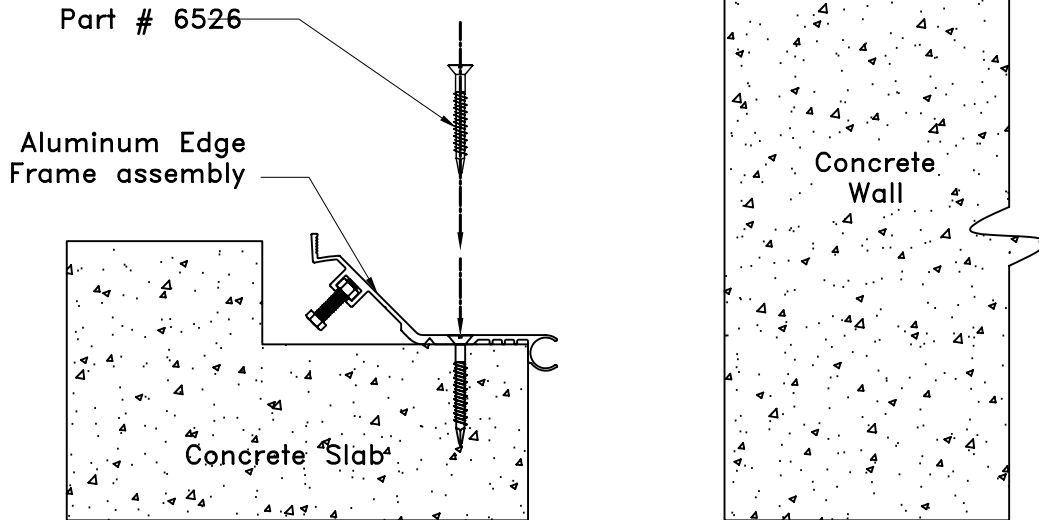

3c

Fasten Aluminum Edge Frame Assembly securely using Threaded Anchor Rawl Tapper #2764 1/4" x 2-1/4" (Part No. 6526) Utilizing predrilled countersunk holes.

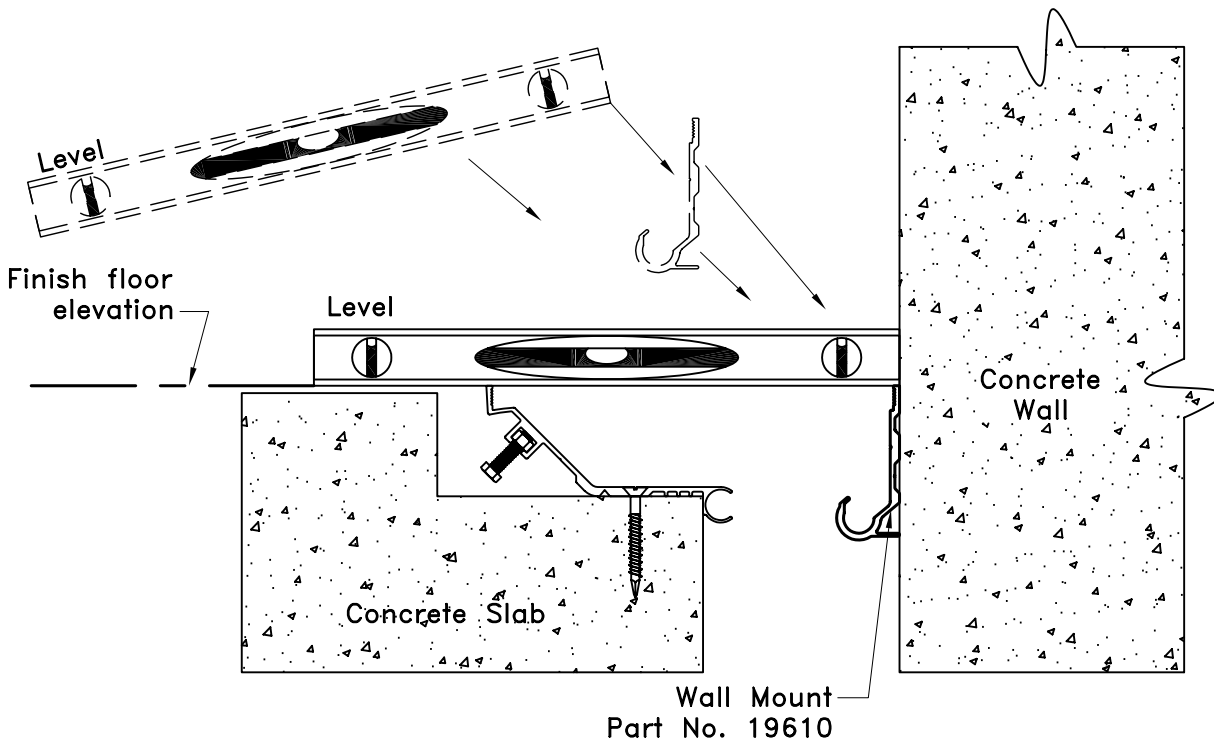

4a

In preparation for fastening Wall Mount Extrusion (Part No. 19610), hold ext against wall and making sure that it is LEVEL with the adjacent Aluminum Edge Frame Assembly. Snap a chalk line to insure level installation. Use 5 foot piece Wall Mount at start of each joint run.

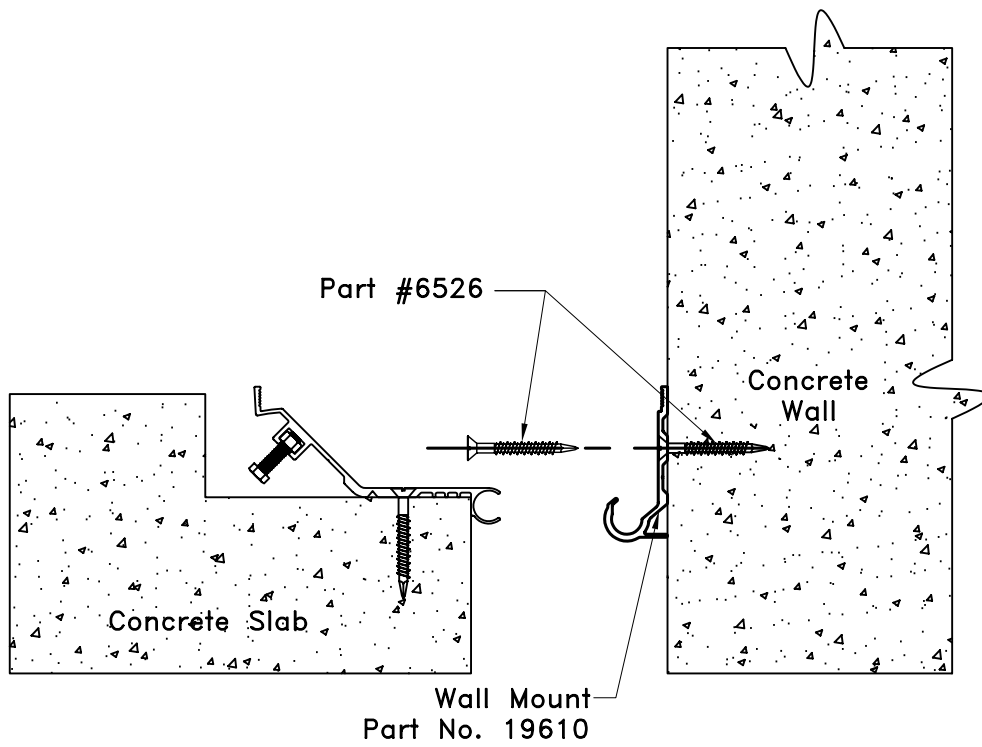

4b

Fasten Wall Mount with part no. 6526 utilizing pre-drilled countersunk holes.

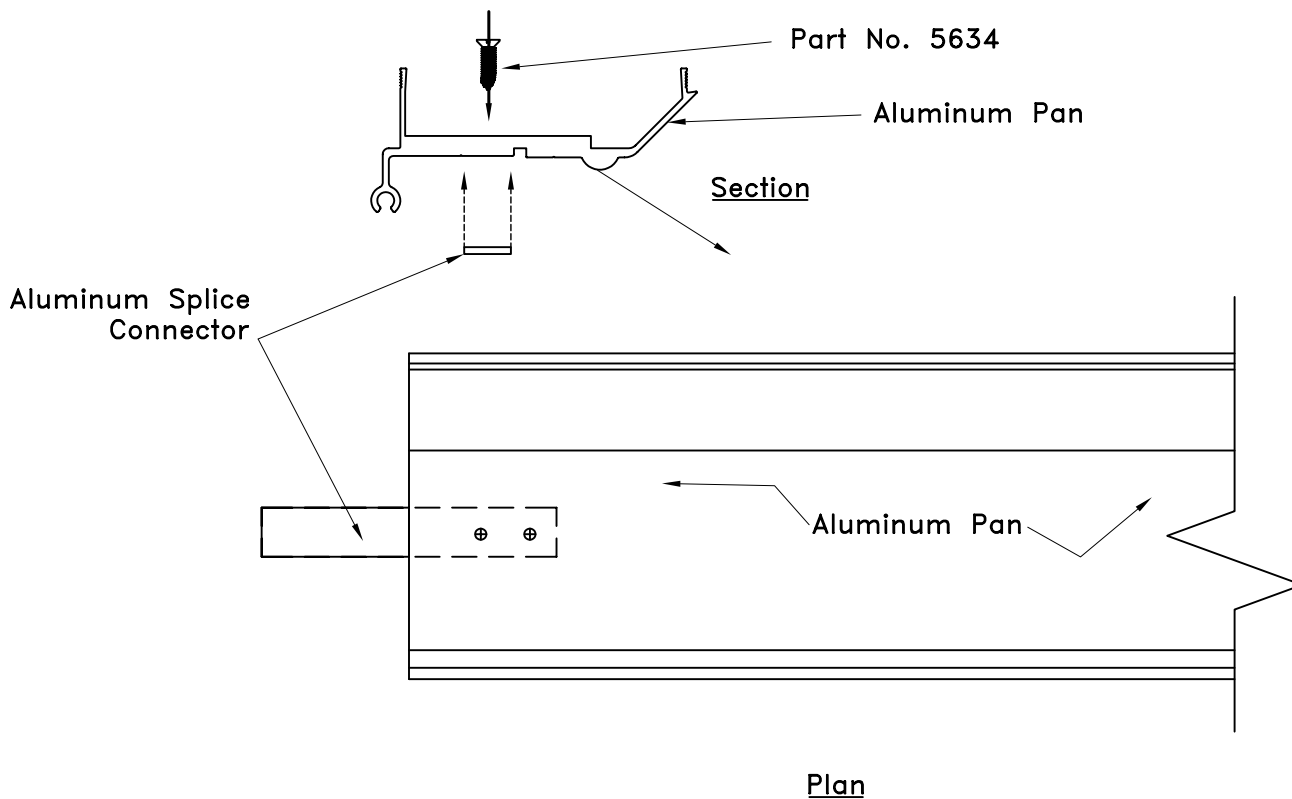

5

After aluminum edge frames and Seismic-centering bars are installed, start adding butt splice connectors to one end of each aluminum pan using factory holes provided and part no. 5634 (Screw 1/4" x 1" FTPN)

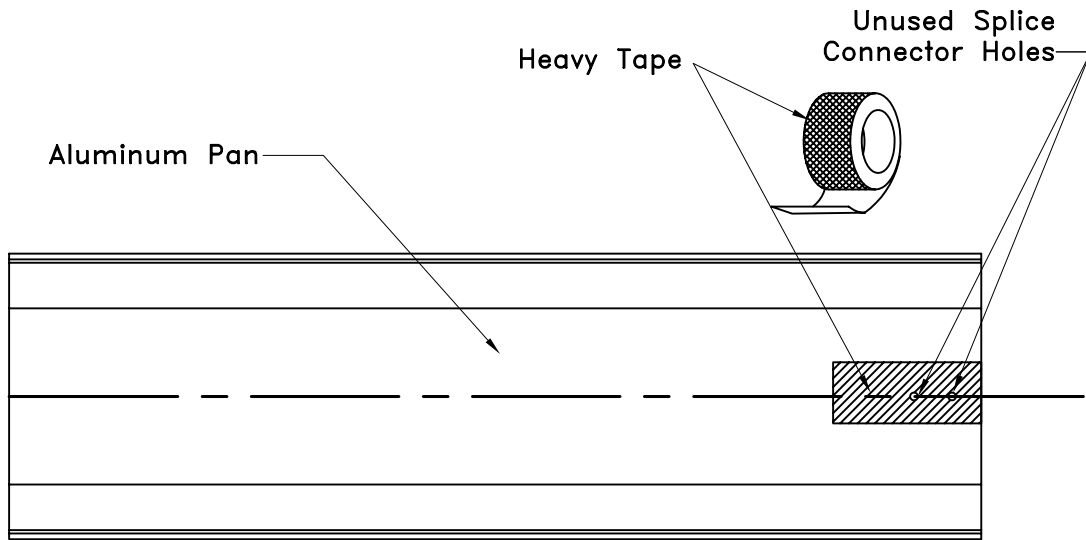

- 6 Use Heavy Tape to cover un-used splice connector holes (this will be at the first aluminum pan to be installed against the wall).
-

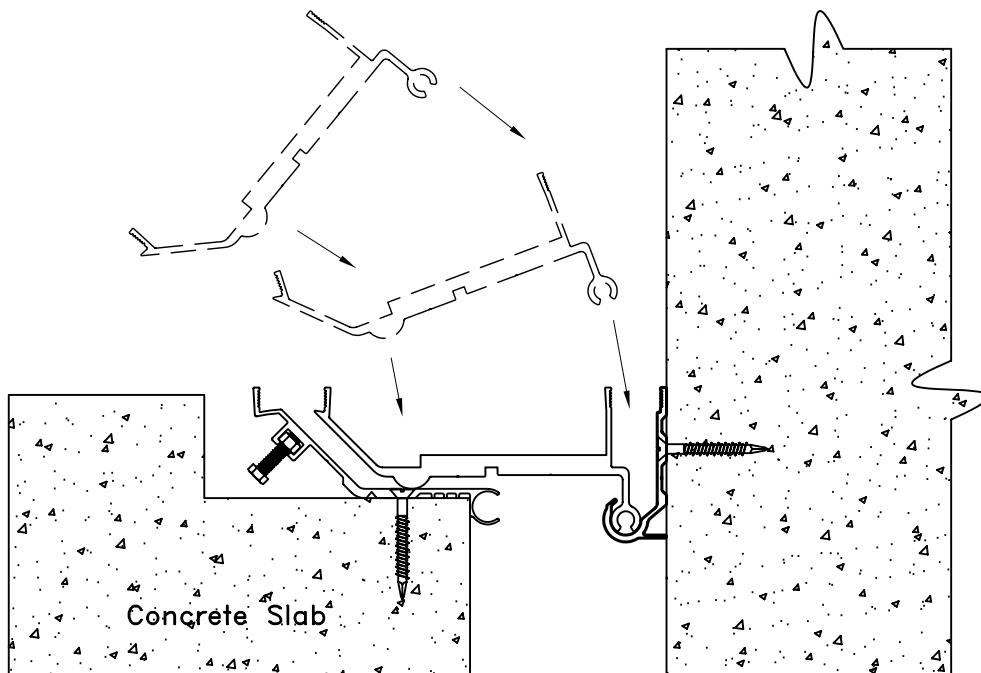

- 7 Gently set Aluminum Pans into place as shown above. See Steps 8 & 9 for splicing procedure

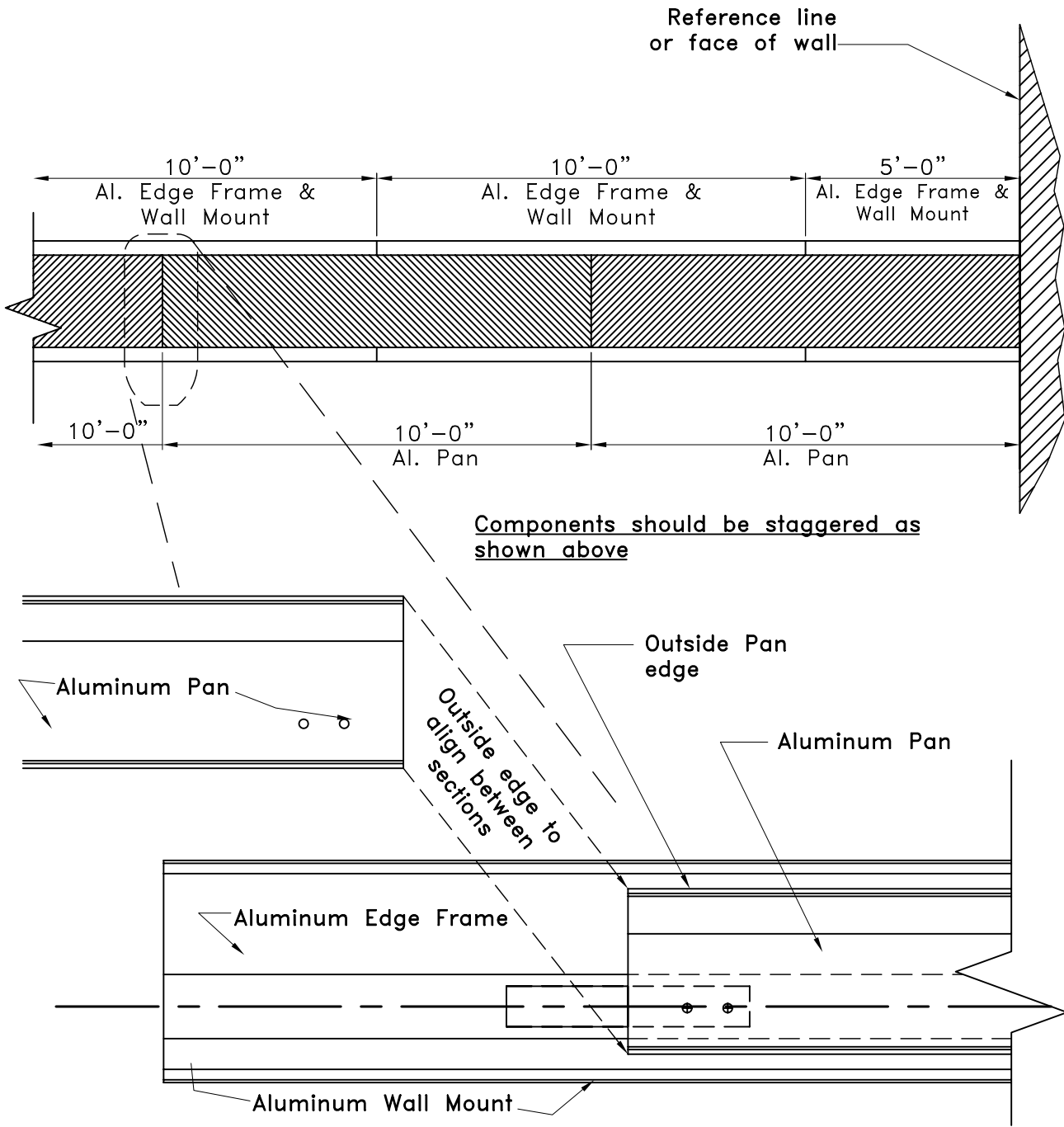

8

Set in next Aluminum Pan snug against previously laid in Aluminum Pan. See Step 9 for splicing the two together. Ensure Aluminum pan sections butt tightly together and that the outside edges align from section to section.

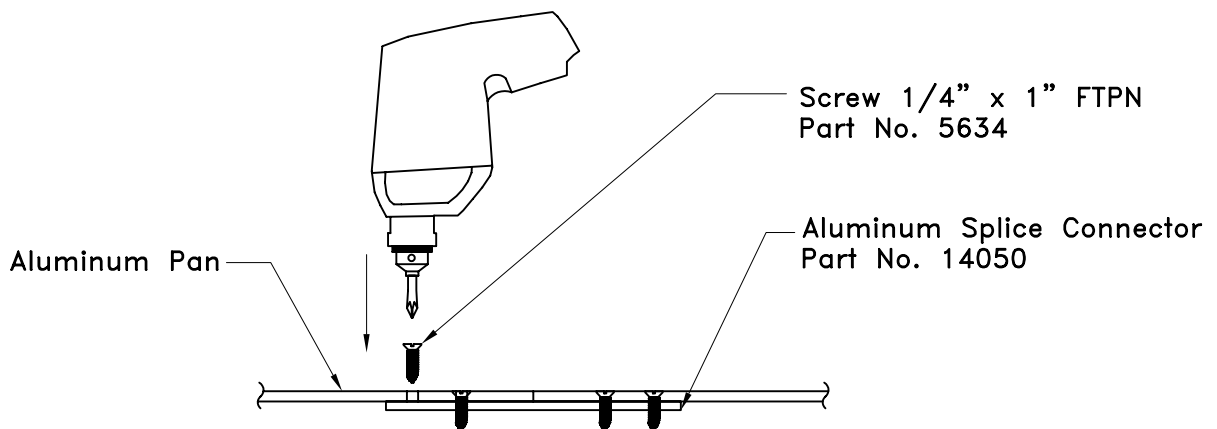
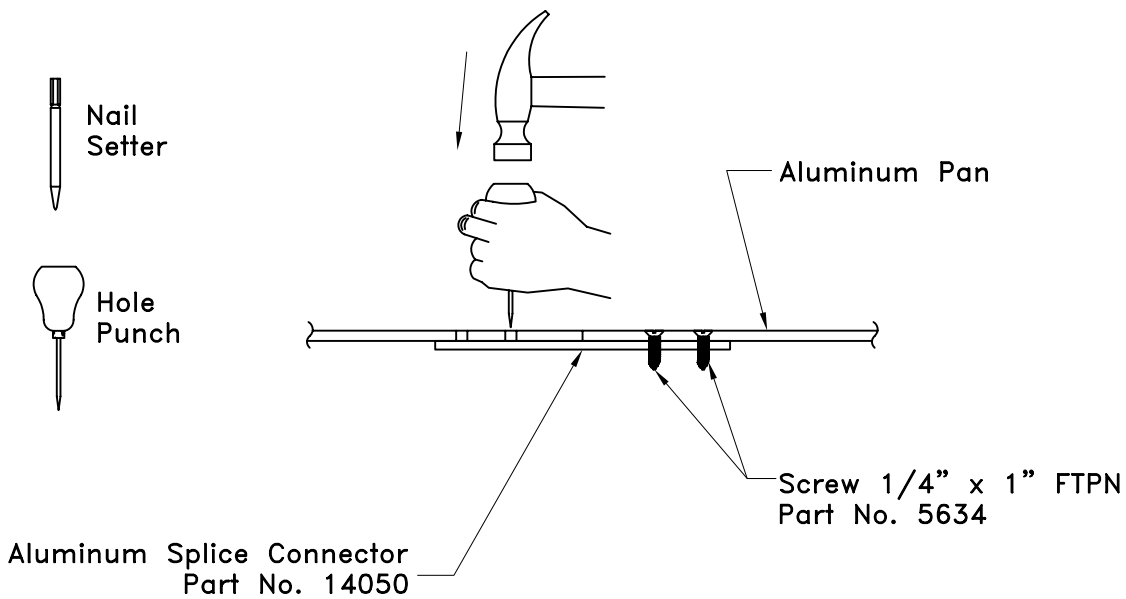
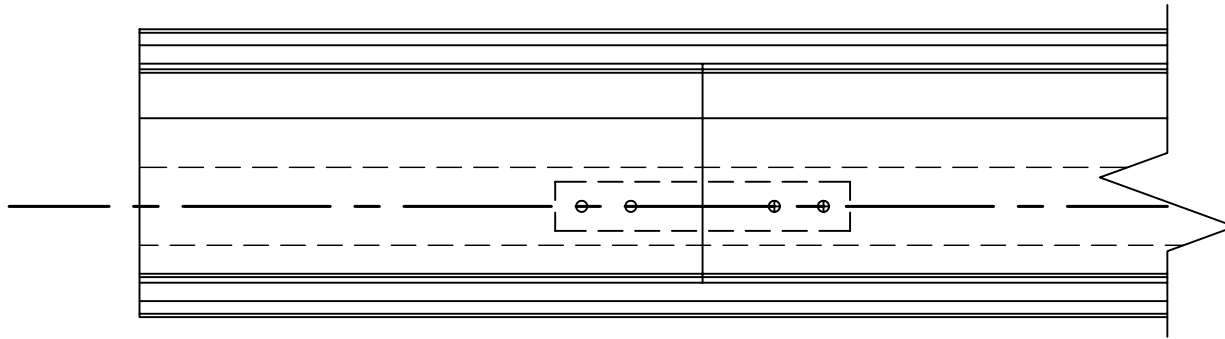

- 9 Using the splice connector holes in the Aluminum Pan as a guide, firmly tap in guide marks into the aluminum splice connector below utilizing either a nail setter or hole punch. Pre-drill 3/16" dia. pilot hole in connector. Use self tapping screws (Part No. 5634) to complete splicing of pan systems together.

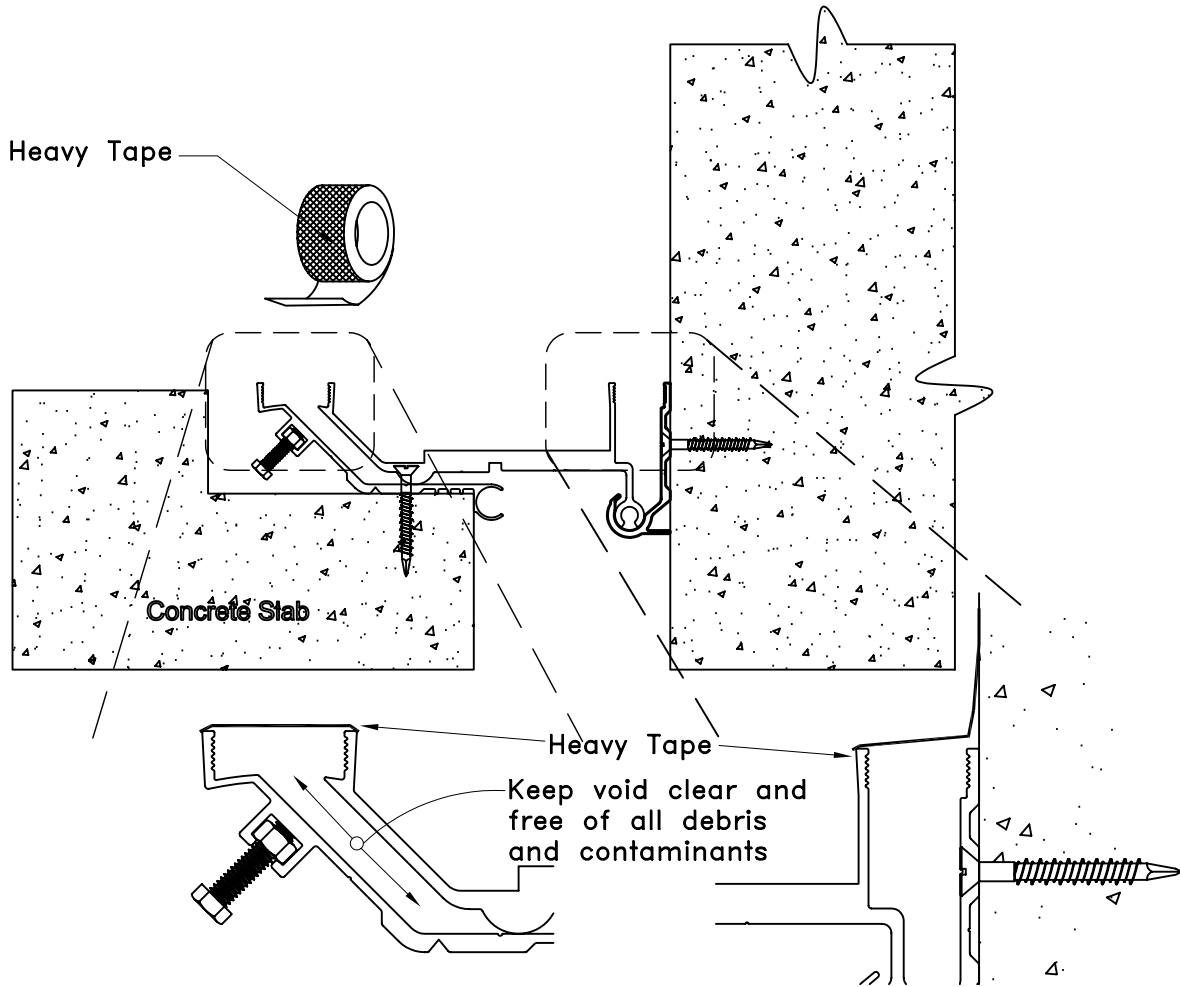

10 Use heavy tape continuously to protect joint opening through the next final steps.

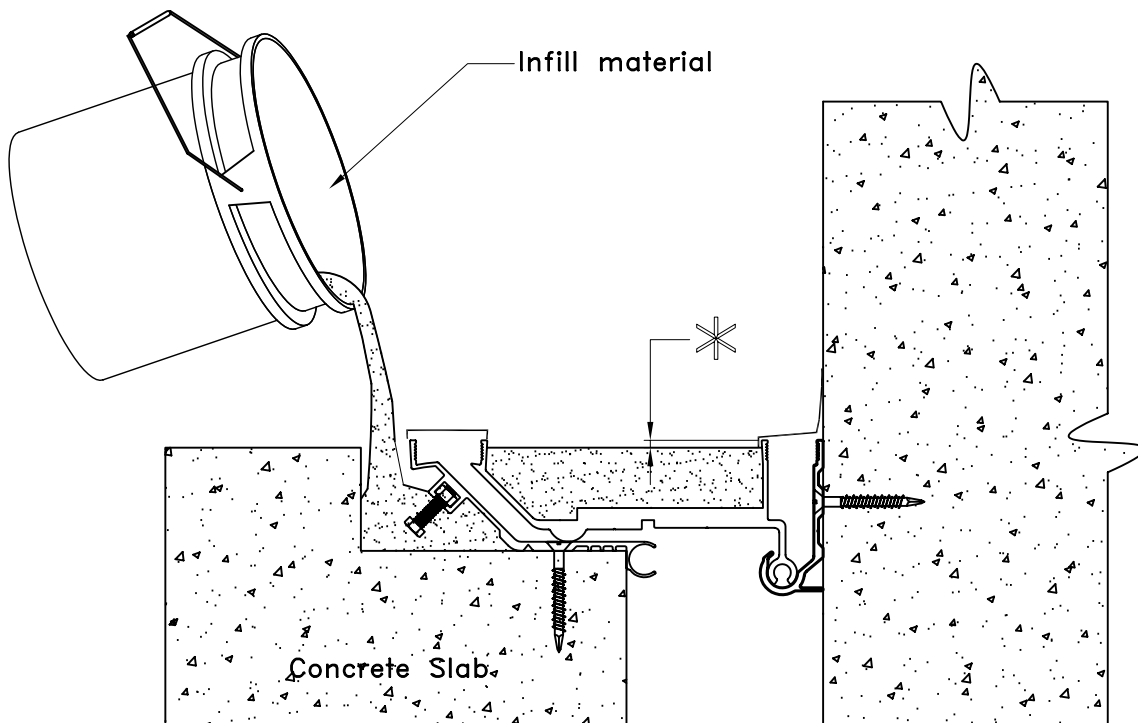

11 Pour infill material into blockout voids and Pan cavity. *Warning! Leave required recess for finish floor finish material thickness and proper placement

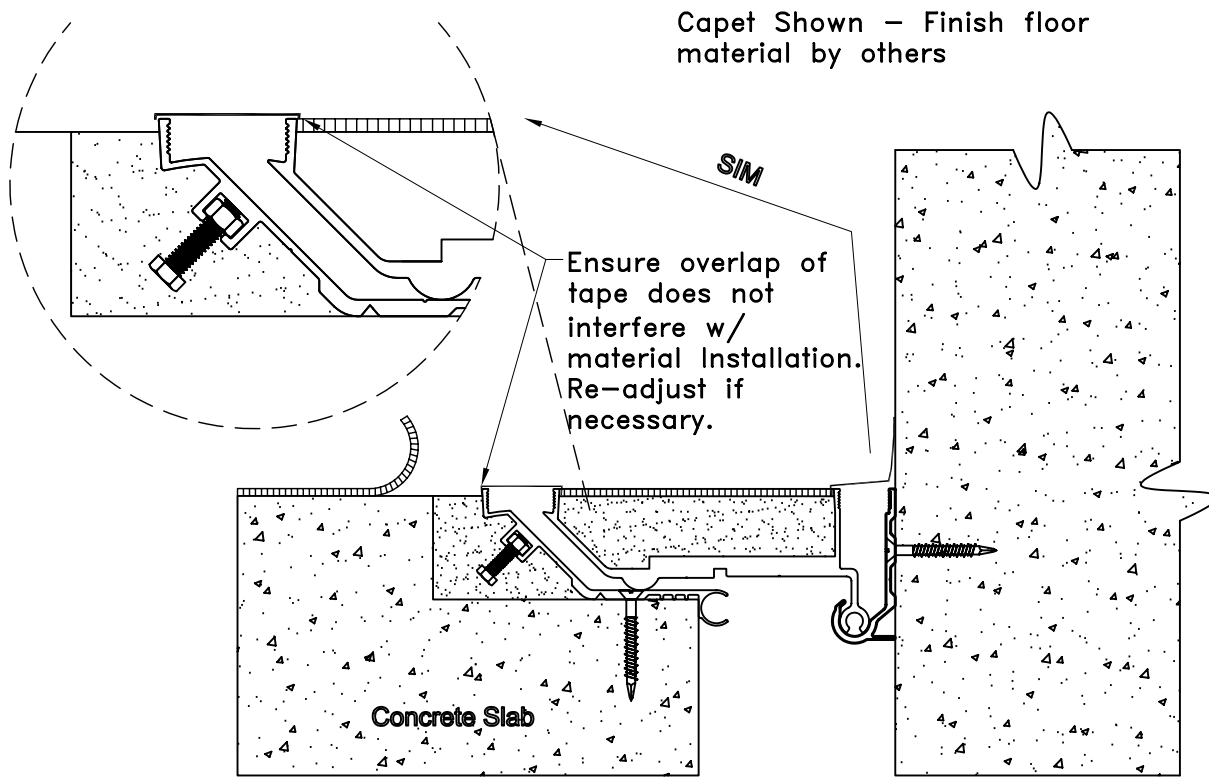

12 Install flooring material. Keep joint opening protected until surrounding flooring installation is complete

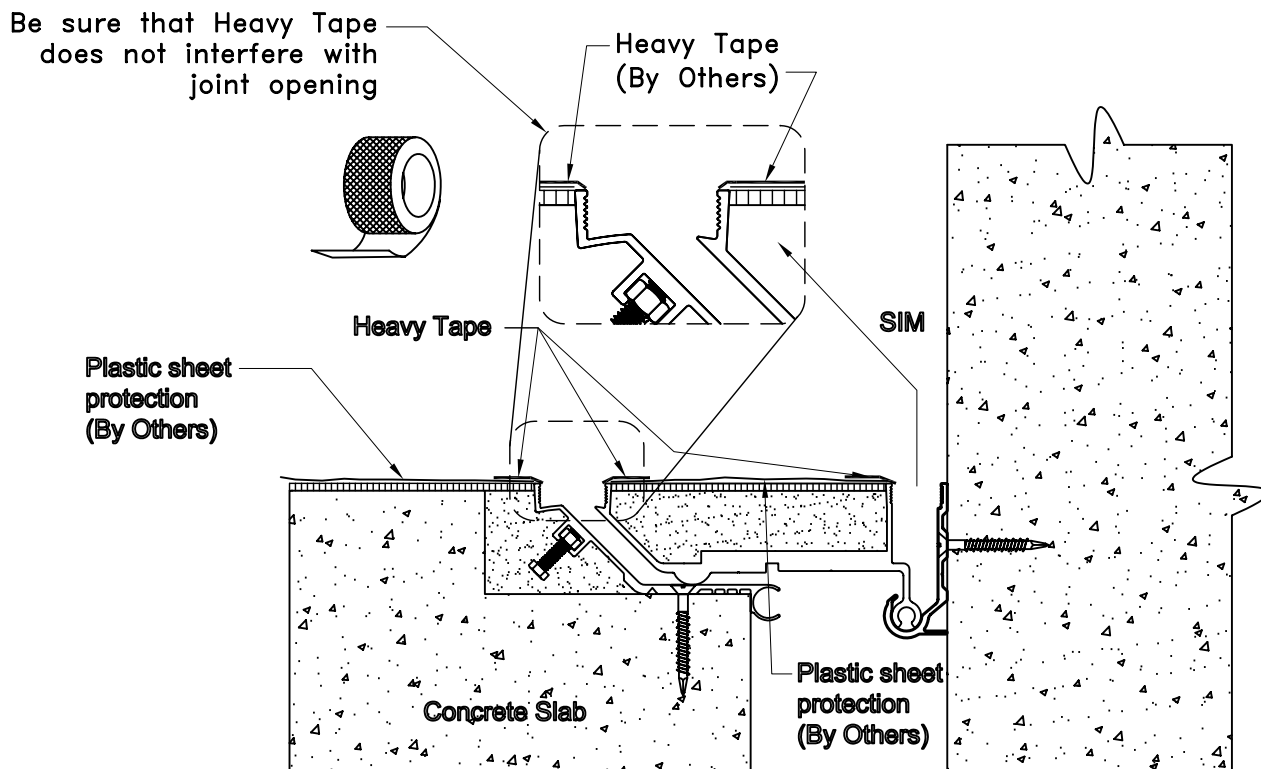

13 Remove Heavy Tape from joint opening. Protect surrounding finish floor material using Heavy Tape and Heavy Gauge Plastic Sheeting

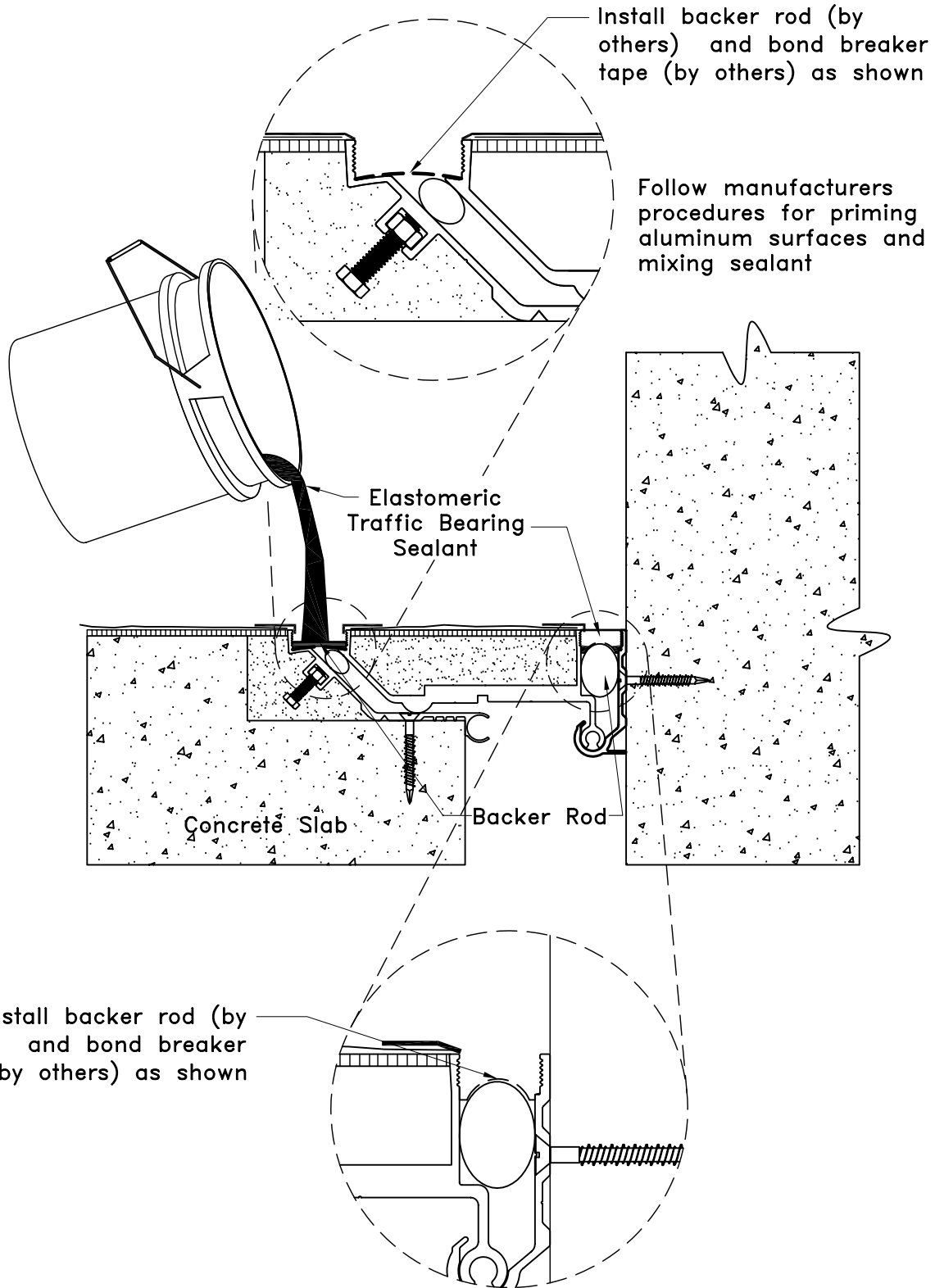

14 Install Backer Rod, Bond Breaker Tape (Supplied by others) & Sealant (Supplied by others)

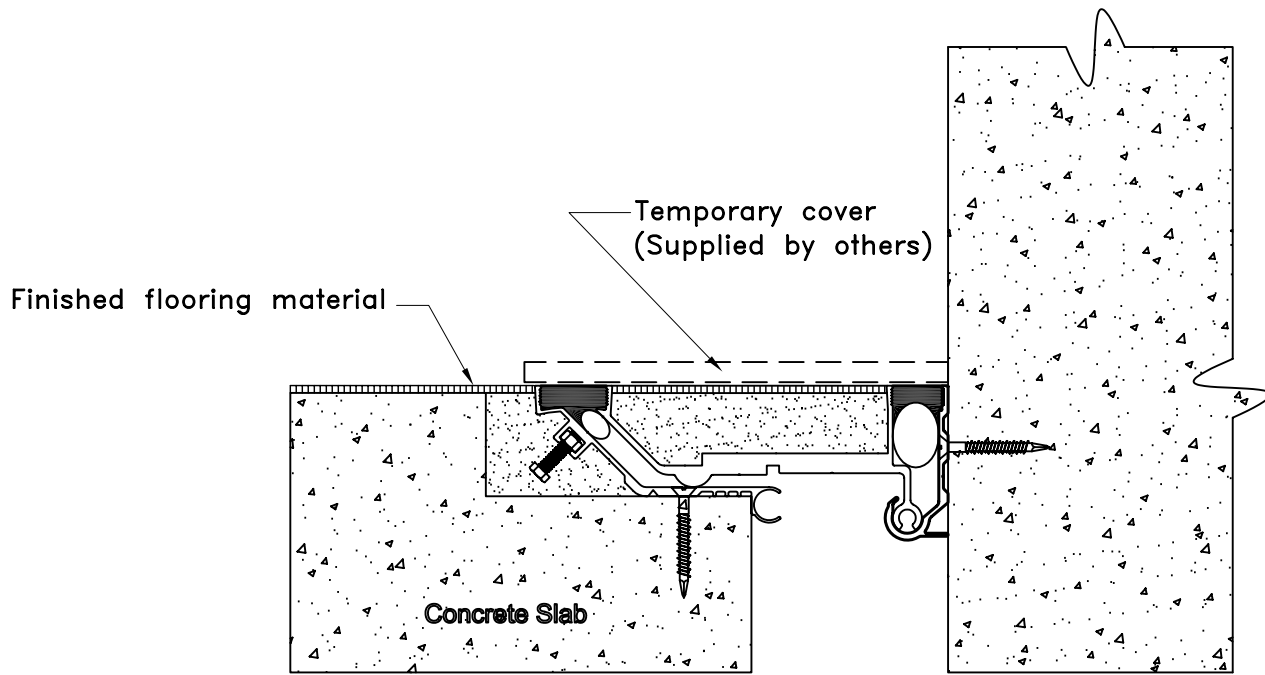

15

Installing contractor shell cover and protect the finished expansion joint assembly from damage during installation of finish floor materials. The expansion joint assembly is a finished product. Damage to expansion joint finishes and components are excluded from warranty