

EJ-SFNB Series

Expansion joint cover for floors
Floor to floor condition

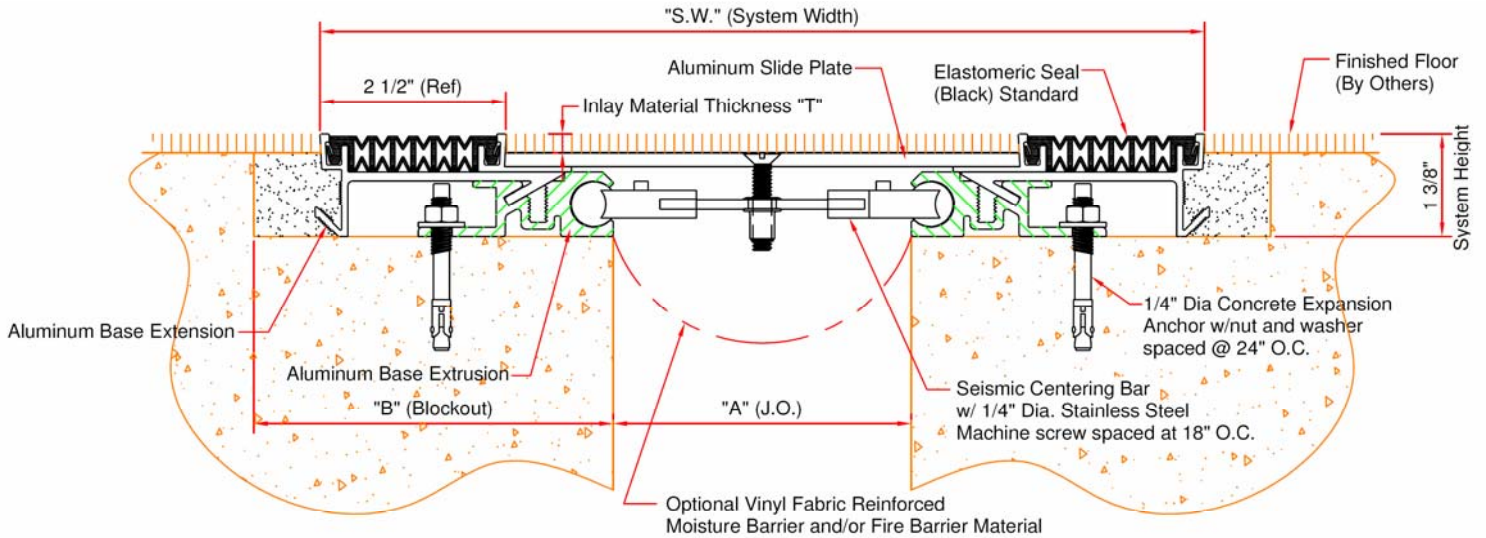

EJ-SFNB-200 Thru EJ-SFNB-1200

Model	"A" Min	"A" Mid	"A" Max	"B"	SW @ "A" Mid	Total Seismic Movement	"T"
-SFNB-200	1"(25)	2"(51)	3"(76)	5"(127)	9 7/8"(251)	2"(51)	1/4"(6)
-SFNB-400	1"(25)	4"(102)	6"(152)	5"(127)	11 7/8"(302)	5"(127)	1/4"(6)
-SFNB-600	1"(25)	6"(152)	9"(229)	6"(152)	15 7/8"(403)	8"(203)	1/4"(6)
-SFNB-800	1"(25)	8"(203)	12"(305)	6"(152)	17 7/8"(454)	11"(279)	1/4"(6)
-SFNB-1000	1"(25)	10"(254)	15"(381)	7"(178)	21 7/8"(556)	14"(356)	1/4"(6)
-SFNB-1200	1"(25)	12"(305)	18"(457)	7"(178)	23 7/8"(606)	17"(432)	3/16"(5)



Right to site.

Call: 800-547-2635 Fax: 800-317-8770
USA or Canada
Web: www.nystrom.com
E-mail: info@nystrom.com

PROJECT:

CONTRACTOR:

ARCHITECT:

INITIALS: QTY: DATE: PART NUMBER: