

PLAN VIEW
(NOT TO SCALE)

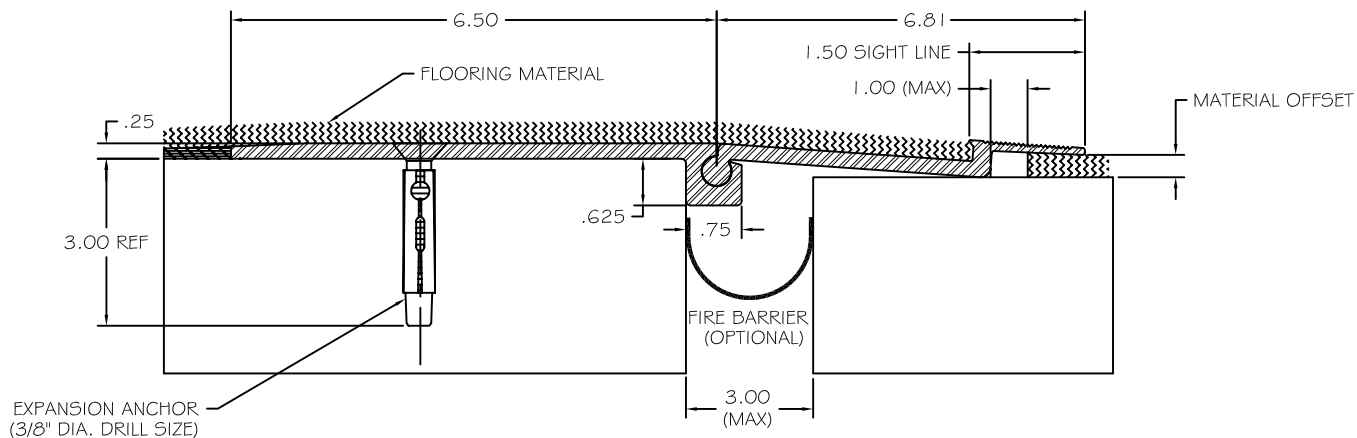

SURFACE CROSS SECTION
NOT TO SCALE

NOTE: MALE PIECE RESTS ON LOWER PIECE (WHEN APPLICABLE)
APPROX. 2" VERTICAL MOVEMENT WITH HINGE JOINT (10% TOTAL ROTATIONAL MOVEMENT)

SPECIFICATIONS

- 6063-T6 ALUMINUM
- MILL FINISH
- SUPPLIED WITH EXPANSION ANCHORS
- STANDARD LENGTH=10' / SECTION

PART NUMBER	MATERIAL OFFSET
FA150-125	.125
FA150-250	.250
FA150-375	.375

LOAD	JOINT OPENING		
	1"	2"	3"
CONCENTRATED (MAX)	325#	250#	200#
UNIFORM (MAX)	200 PSI	150 PSI	100 PSI