

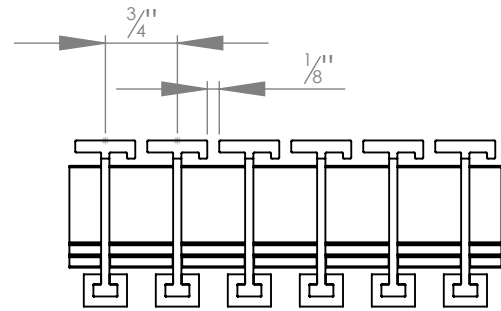

G-550 THIN LINE WAFFLE GRATE DETAIL

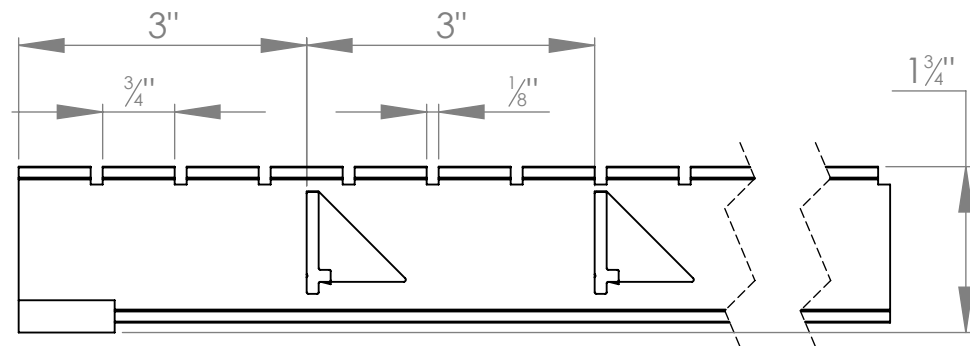

WIDTH VIEW



LENGTH VIEW

STRIATIONS CUT PERPENDICULAR TO THE TREAD RAILS CREATE A CLEAN GRID PATTERN THAT REMOVES DIRT REGARDLESS OF THE DIRECTION TRAFFIC PASSES. CONSTRUCTED WITH STURDY KEYLOCKS EVERY THREE INCHES, THIN LINE GRATE CAN STAND UP TO ALMOST ANY TRAFFIC EPOXY RESIN GRIT HAS A HIGH COEFFICIENT OF FRICTION TO PREVENT SLIPPING HAZARDS.

DETAIL NOTES:

- 1-TREAD RAILS MUST RUN PERPENDICULAR TO TRAFFIC DIRECTION.
- 2-TRAFFIC DIRECTION DIMENSION CAN ONLY BE CHANGED IN 3/4" (19.1MM) INCREMENTS UNLESS ALUMINUM FILLER IS ATTACHED TO THE FRAME.
- 3-GRATE DIMENSIONS ALLOW FOR CLEARANCE BETWEEN GRATE SECTIONS AND FRAME IN THE WIDTH DIMENSION.

SPECIFICATIONS:

GRATEDESIGN MODEL G-550 HAS OUR THIN LINE WAFFLE GRATE RAIL THAT IS MADE WITH 6063-T52 ALLOY RAILS AND ARE 1-3/4" (44.5MM) DEEP AND, SPACED 3/4" (19.1MM) ON CENTER. WITH KEYLOCKS SPACED 3" (76.2MM) ON CENTER. FRAMES USED WITH THE G-550 ARE: TYPE F-1 LEVEL BED; TYPE F-LANG LARGE ANGLE; TYPE F-2 DEEP PIT; TYPE F-2T THIN SLAB FRAMES WHICH ARE MADE OF ALUMINUM.

Arden
Architectural
Specialties, Inc.
9300 73rd Avenue North
Brooklyn Park, MN 55428

JOB REF.	
MODEL NO.	G-550
RELEASED DATE	6/3/2010
SHEET	1 OF 1