

WIDTH VIEW

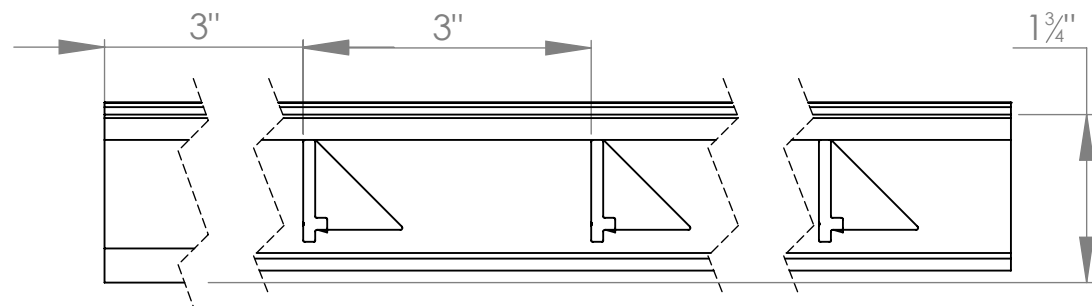

LENGTH VIEW

OUR SCRAPESGRATE ENTRANCE MATS HAVE SCRAPER BARS THAT ALTERNATE WITH AN ABSORBENT ULTRASORB TREAD FOR INDOOR USE OR HEAVY-DUTY RUGGED SCRUB FOR OUTDOOR USE. WATER AND DIRT ARE SCRAPED OFF AND FUNNELED UNDER THE MAT AT THE DOOR SO THE FLOOR STAYS CLEAN. THIS PRODUCT CARRIES A FIVE YEAR WARRANTY.

**DETAIL NOTES:**

- 1-TREAD RAILS MUST RUN PERPENDICULAR TO TRAFFIC DIRECTION.
- 2-GRATE DIMENSIONS ALLOW FOR CLEARANCE BETWEEN GRATE SECTIONS AND FRAME IN THE WIDTH DIMENSION ONLY.
- 3-TRIM THE FILLER TO ENSURE A TIGHT FIT IN THE TRAFFIC DIMENSION

**SPECIFICATIONS:**

GRATEDESIGN MODEL G-525DKRS HAS OUR 600 DENIER TUFTED POLYPROPYLENE RUGGED SCRUB TREADS HAVE PRIMARY AND SECONDARY BACKING. THEN ALTERNATES WITH A SCRAPER BAR. RAILS ARE MADE WITH 6063-T52 ALLOY RAILS. ARE 1-3/4" (44.5MM) DEEP AND, SPACED 1-1/8" (28.6MM) ON CENTER. WITH KEYLOCKS SPACED 3" (76.2MM) ON CENTER. FRAMES USED WITH THE G-525DKRS ARE: TYPE F-1 LEVEL BED; TYPE F-LANG LARGE ANGLE; TYPE F-2 DEEP PIT; TYPE F-2T THIN SLAB FRAMES WHICH ARE MADE OF ALUMINUM.

 Arden Architectural Specialties, Inc.™  
 9300 73rd Avenue North  
 Brooklyn Park, MN 55428

JOB REF.	
MODEL NO.	<b>G-525DKRS</b>
RELEASED DATE	6/3/2010
SHEET 1 OF 1	