

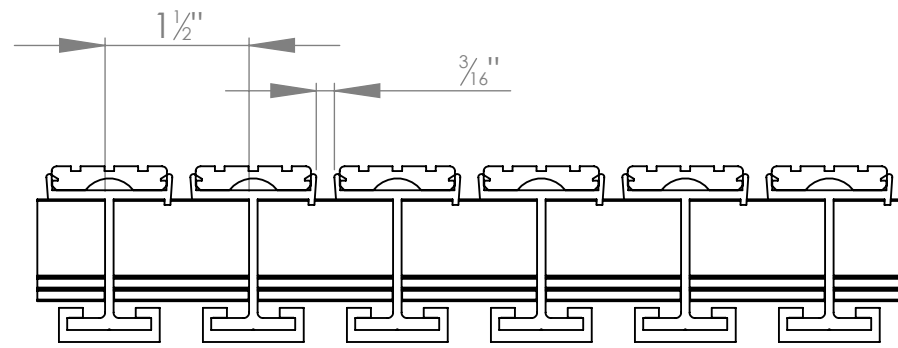

# G-200RT GRATE DETAIL

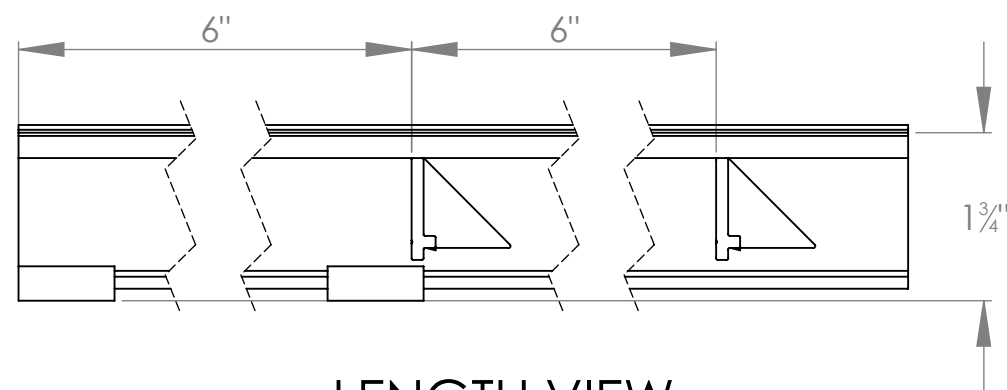

WIDTH VIEW



LENGTH VIEW

OUR RIGID GRATE ARE MECHANICALLY JOINED KEYLOCK EVERY SIX INCHES MAKES OUR STANDARD GRATES THE STRONGEST GRATES OF THEIR TYPE ON THE MARKET. WE ALSO PROVIDE AN OPTIONAL THREE-INCH SPACING FOR GRATES IN AREAS THAT REQUIRE HEAVY ROLLING LOADS

**DETAIL NOTES:**

- 1-TREAD RAILS MUST RUN PERPENDICULAR TO TRAFFIC DIRECTION.
- 2-TRAFFIC DIRECTION DIMENSION CAN ONLY BE CHANGED IN 1-1/2" (38.1MM) INCREMENTS UNLESS ALUMINUM FILLER IS ATTACHED TO THE FRAME.
- 3-GRATE DIMENSIONS ALLOW FOR CLEARANCE BETWEEN GRATE SECTIONS AND FRAME IN THE WIDTH DIMENSION.

**SPECIFICATIONS:**

GRATEDESIGN MODEL G-200RT HAS OUR RUBBER TREAD, WHICH IS EXTRUDED BLACK VULCANIZED RUBBER WITH CONVEX SHAPE AND CONTINUOUS SERRATIONS. RAILS ARE MADE WITH 6063-T52 ALLOY RAILS AND ARE 1-3/4" (44.5MM) DEEP AND, SPACED 1-1/2" (38.1MM) ON CENTER. WITH KEYLOCKS SPACED 6" (152.4MM) ON CENTER. FRAMES USED WITH THE G-200RT ARE: TYPE F-1 LEVEL BED; TYPE F-LANG LARGE ANGLE; TYPE F-2 DEEP PIT; TYPE F-2T THIN SLAB FRAMES WHICH ARE MADE OF ALUMINUM.

Arden  
Architectural  
Specialties, Inc.  
9300 73rd Avenue North  
Brooklyn Park, MN 55428

JOB REF.

MODEL NO. **G-200RT**

RELEASED DATE 6/3/2010

SHEET 1 OF 1