

XLERATOR® HAND DRYER



MODELS: **XL - BW** **W** **GR** **C** **SB** **SI** **SP** OPTIONS: **-1.1N** (Noise Reduction Nozzle) **-H** (HEPA Filter) **-VOLTAGE** (See Chart)



XL-BW
White Thermoset Resin (BMC)



XL-W
White Epoxy Painted



XL-GR
Graphite Textured Painted



XL-C
Chrome Plated



XL-SB
Brushed Stainless Steel



XL-SI**
Custom Special Image



XL-SP***
Custom Special Paint

* Dry time based on third party testing performed by SGS International on standard XLERATOR hand dryer with 0.8 nozzle to 0.2g or less of residual moisture.
 ** Exclusive digital image technology allows for the addition of company, school or team logos with any color, design or a 'green message'.
 *** Special Paint powder-coated covers are available in many colors and textures.

FOR ARCHITECT/ENGINEER APPROVAL

Job Name _____ Date _____

Model Specified _____ Quantity _____

Variations Specified _____

Customer/Wholesaler _____

Contractor _____

Architect _____

PERFORMANCE

- A. Dry Time: 10-15 Seconds*
- B. Wattage: 1500 Watts
- C. Certifications:



CONSTRUCTION

- A. All covers will be fastened to a base plate by two chrome plated tamper-proof bolts.
 Cover shall be one of the following:
Die-cast zinc alloy - One-piece, heavy-duty, rib-reinforced, lightweight, unbreakable, rustproof and all exposed surfaces shall be bright chrome plated or finished with chip-proof, electrostatically applied epoxy paint.
Bulk Molding Compound (BMC) - White reinforced thermoset resin.
Stainless Steel - with a brushed finish.
Special Image - Digital image applied to die-cast or stainless steel covers using patented Kolorfusion Sublimation Decoration process.
- B. Base plate shall be equipped with (3) 7/8" (22 mm) diameter holes, the bottom one is suitable for use with surface conduit.
- C. All internal parts shall be coated according to Underwriters' Laboratories, Inc. requirements.
- D. Entire mechanism shall be internally grounded.
- E. Options
HEPA Filtration System: Filters 99.97% of bacteria and particles at .3 microns out of the air.
1.1 Noise Reduction Nozzle: Lowers decibel level 9 dB by reducing air deflection noise but increases dry time by 2-3 seconds.
- F. Accessories (optional)
Sound and Speed Control: 40112 (110V), 40113 (208-240V)
Microban® Antimicrobial Wall Guards: 89W (White), 89B (Black), 89S (Stainless)
XChanger Paper Towel Retrofit Kit: 40550, 40551 (ADA Height)
ADA Recess Kit: 40502

MECHANISM

- A. Motor shall be a thermally protected, series commutated, through-flow discharge vacuum motor/blower (5/8 hp / 20,000 rpm) which provides air velocity of up to 19,000 LFM (linear feet per minute) at the air outlet and 16,000 LFM at the hands (4 inches [102 mm] below air outlet).
- B. Heating element (970 w) is constructed of Nichrome wire and mounted inside the blower housing, thereby being vandal proof. It shall be protected by an automatic resetting thermostat, which shall open whenever air flow is cut off and shall close when flow of air is resumed. It shall produce an air temperature of up to 135°F (57°C) at a 72°F (22°C) ambient room temperature at the hands (4 inches [102 mm] below air outlet).
- C. Control assembly is activated by an infrared optical sensor located next to the air outlet. The dryer shall operate as long as hands are under the air outlet. There is a 35-second lockout feature if hands are not removed.

LIMITED WARRANTY

The dryer shall be guaranteed to be free from defects for a period of five (5) years. Warranty shall include labor performed at factory as well as the repair or exchange of defective parts, at manufacturer's option.

QUANTITY RECOMMENDATIONS

One dryer for every two washbasins is sufficient for most applications. If restroom traffic is unusually heavy, we suggest one dryer per washbasin in small installations and two dryers for every three washbasins in larger installations. When a 54" washfountain is used, we suggest four to five dryers.

XLERATOR® HAND DRYER



MODELS: **XL - BW W GR C SB SI SP** OPTIONS: **-1.1N** (Noise Reduction Nozzle) **-H** (HEPA Filter) **-VOLTAGE** (See Chart)

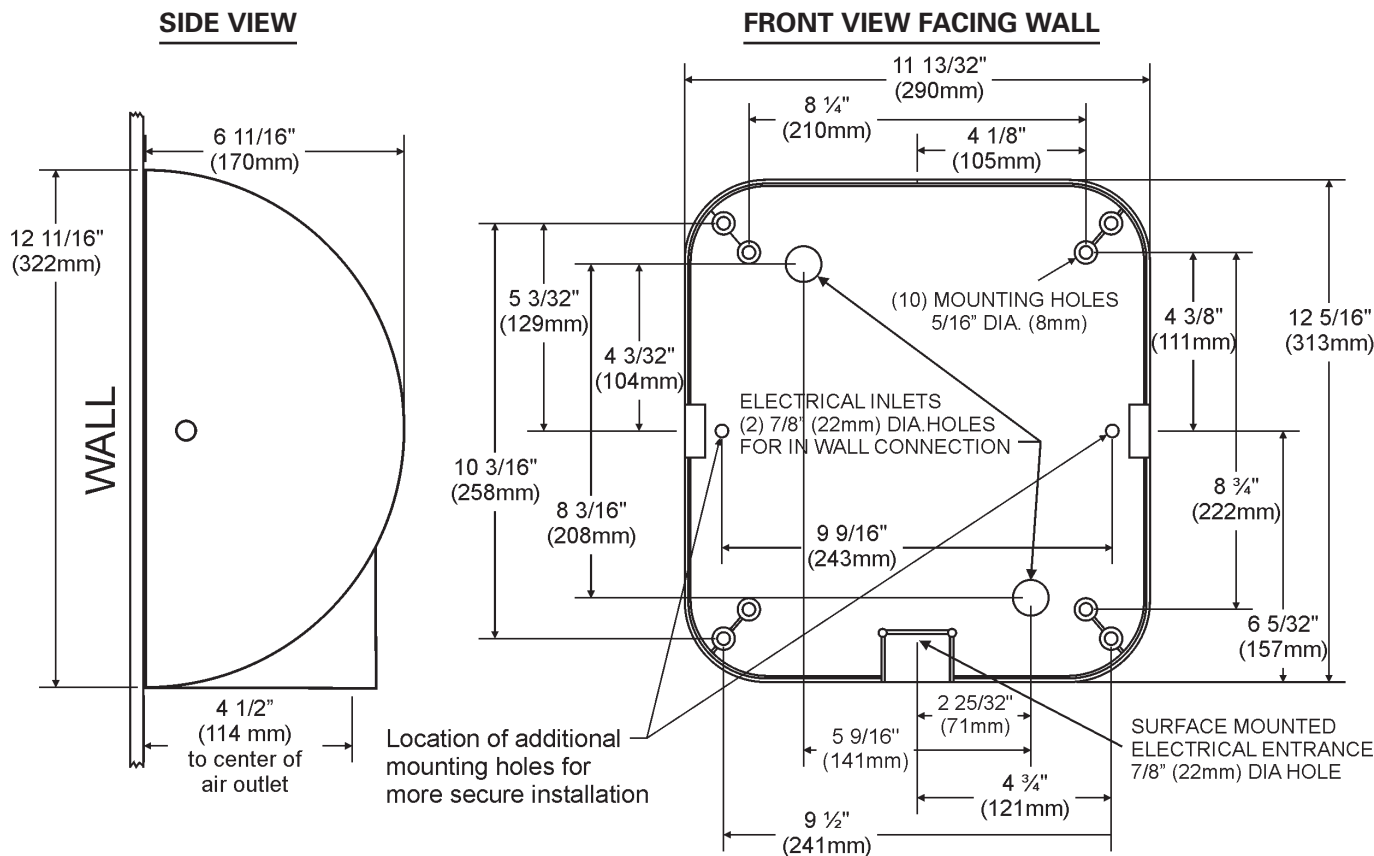

DIMENSIONS

Width 11 3/4" (298 mm) Height 12 11/16" (322 mm) Depth 6 11/16" (170 mm)

WEIGHT

XL-BW: 15 lbs. (6.8 kgs.) XL-SB: 16 lbs. (7.26 kgs.) XL-W, GR, C, SI, SP: 17 lbs. (7.71 kgs.)

ELECTRICAL

Units are Single Phase 1500 Watts and available as specified in:

110-120V	12.5A	60 Hz	cUL US
208V	7A	50/60 Hz	cUL US
220-240V	6.5A	50/60 Hz	cUL US
277V	5.5A	60 Hz	cUL US
230V	6.5A	50 Hz	CE

SUGGESTED MOUNTING HEIGHTS from floor to bottom of dryer:

Men	45" (114 cm)
Women	43" (109 cm)
Teenagers	41" (104 cm)
Small Children	35" (89 cm)
Handicapped	37" (94 cm)



ACTIVATION

Automatic Sensor Operated

MOUNTING

Surface Mounted

OPTIONAL ADA-COMPLIANT RECESS KIT



Part # 40502

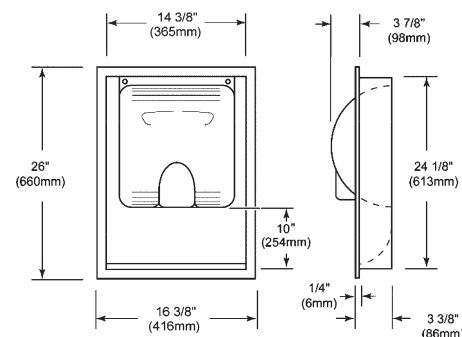

DIMENSIONS

Width 16 3/8" (416 mm) Height 26" (660 mm) Depth 3 3/8" (86 mm)

WEIGHT

11 lbs. (4.99 kgs.)

Bottom of recessed wall box should be 10" (254 mm) below suggested mounting height for dryer.