



# FINALLY... A *FAST* HAND DRYER



THREE TIMES FASTER - DRIES HANDS IN 10 TO 15 SECONDS • USES 80% LESS ENERGY  
95% COST SAVINGS VS. PAPER TOWELS • GREENSPEC APPROVED • HELPS QUALIFY FOR LEED CREDITS

THE FINEST HAND AND HAIR DRYERS AVAILABLE





**Excel Dryer, Inc.** manufactures the industry's finest quality hand and hair dryers. For more than 45 years, Excel's full line of **American-made** dryers has provided cost-effective hand and hair dryers for schools, hospitals, airports, service stations, correctional facilities, restaurants, stadiums, movie theaters, health clubs, office buildings, factories, hotels and many other commercial facilities.

At Excel, quality is a way of life. Nothing else is acceptable. This philosophy has always guided us in developing products that are dependable, easy to install or service, and satisfying to use.

Excel Dryer, Inc. is headquartered in East Longmeadow, Massachusetts. Our products are marketed through an established network of sales representatives who call on more than 4,000 distributors nationally. Excel Dryers can be specified in 50hz or 60hz and from 100V to 277V for distribution worldwide.

## Why Buy Excel Hand Dryers

### Excel Dryer Leads the Industry in Quality and Customer Service

- 95% Cost Savings vs. Paper Towels
- Good For The Environment
- Best Warranty
- Promotes Hygiene
- Source Reduction Alternative
- Reduced Vandalism
- Labor Savings
- Easy Access For The Disabled

## The Excel Dryer Difference

- All Excel Dryer models are made in the USA.
- We design and manufacture our own infrared-activated controls and adjustable electronic timers.
- We do our own chrome plating to produce a flawless mirror-like finish.
- We test 100% of our dryers under current load prior to shipment.
- We offer the Industry's best warranty: Including a 10-year UNLIMITED Warranty on all Hands On<sup>®</sup> models (includes damage due to accidents, misuse or vandalism).
- Excel Hand Dryers do not need service centers – most units can be repaired in the field because parts are modular and easy to change out.



## Good for the Environment

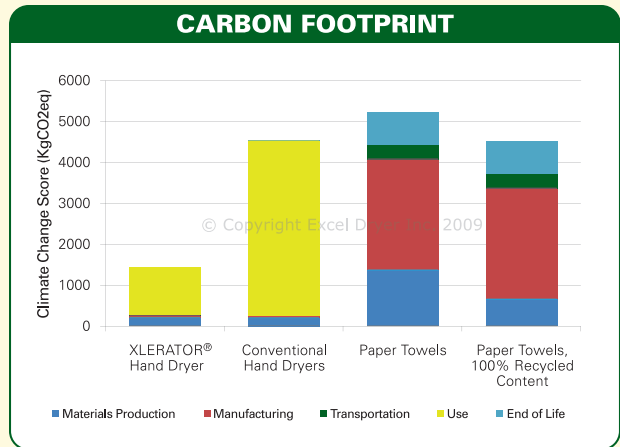

\*Results from our Life Cycle Assessment Study (LCA) which was peer reviewed per ISO 14040 Standards. Contact us to request the study or download it from our website - [www.exceldryer.com/PressKit/green.php](http://www.exceldryer.com/PressKit/green.php)

### Do you know the facts?



**Seventeen trees are consumed to make one ton of paper.**

**One ton of paper production pollutes 20,000 gallons of water.**

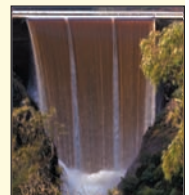

**One ton of paper consumes three cubic yards of landfill.**

**Average cost of paper is 2 cents per hand dry using paper towels vs. 1/10th of a cent using dryers**



# EXCEL DRYER Product Line Categories



## XLERATOR® SERIES

### Finally... A FAST Hand Dryer!

Excel Dryer has made a breakthrough in hand drying technology. The XLERATOR hand dryers deliver 3 TIMES FASTER hand drying power. A user's hands will be thoroughly dry in only 10 to 15 seconds. The XLERATOR also USES 80% LESS ENERGY than other hand dryers and is a great source reduction alternative, delivering a 95% Cost Savings vs. Paper Towels. XLERATOR also is the only hand dryer that is MADE IN USA Certified, the first hand dryer to be GreenSpec® Listed and helps facilities qualify for several LEED® credits.



## CAST COVER SERIES

### HANDS ON® - Push Button Activated Hand and Hair Dryers

Excel's Hands On hand dryers boast a longstanding reputation for quality and reliability. Hands On hand dryers are engineered to provide twice the service-free life of other hand dryers, and are backed by an industry best Ten Year Unlimited Warranty, including damage due to accidents, misuse or vandalism. All Hands On series models can be specified as hair dryers.



### HANDS OFF® - Automatic Sensor Activated Hand Dryers

Excel's Hands Off hand dryers provide exceptionally quiet operation with maximum strength and durability. Performance is backed by a Ten Year Limited Warranty on the hand dryers. (Five years on control assembly and sensor). Surface and semi-recessed wall mounting model options available.

## LEXAN® SERIES

Excel's reputation of providing products with superior performance combines with the economic benefit of this dryer series for maximum value. Lexan series surface mounted hand dryers are constructed with a one piece molded Lexan cover. They are available in push button or fully automatic models.



### Quantity Recommendations

One dryer for every two washbasins is sufficient for most applications. If restroom traffic is unusually heavy, we suggest one dryer per washbasin in small installations and two dryers for every three washbasins in larger installations. When a 54" wash fountain is used, we suggest four to five dryers.

### Underwriters Laboratories, Inc. Listed

All internal parts are manufactured according to Underwriters Laboratories, Inc. requirements. Excel dryers are listed under the re-examination services of Underwriters Laboratories, Inc.



**GSA** Contract Holder  
#GS-07F-0017T

*Excel Dryer has been awarded a contract by the GSA (General Services Administration) which offers special pricing to all Federal Government Agencies.*

Visit Us On The Web For More Detailed Information Including:

- 3 Part CSI Specifications
  - 3D SketchUp Images and CAD Drawings
  - An Automated Cost Savings Analysis Worksheet
  - What's New at Excel Dryer
  - Excel Dryer Inc and its 45 Year History
- And much more @ [www.exceldryer.com](http://www.exceldryer.com)**

# XLERATOR® Hand Dryers

After seven years in the marketplace **XLERATOR** has received numerous awards and designations and is being specified in many high profile places.

**XLERATOR** is now considered . . . **THE NEW INDUSTRY STANDARD!**

The XLERATOR is the first hand dryer ever to be awarded GreenSpec approval by the editors of Environmental Building News. XLERATOR meets a number of GreenSpec standards: it conserves energy, has low maintenance requirements and reduces waste. More simply put, XLERATOR makes your restroom better for the planet.



\* The XLERATOR is also the first hand dryer to help qualify for LEED credits. LEED stands for Leadership in Energy and Environmental Design. All hand dryers save trees and are a great source reduction alternative, but the XLERATOR also saves energy! This is why XLERATOR helps facilities qualify for several different LEED Credits in the new 2009 Rating Systems:

- EA (Earth & Atmosphere) Credit 1 - Optimizing Energy Performance (Now a mandatory credit for all LEED facilities)
- MR Credit 6 Solid Waste Management - Waste Stream Audit
- IEQ Credit 3.1 Green Cleaning - High Performance Cleaning Program
- IO Credit 1 Innovation in Operations
- IO Credit 3 Documenting Sustainable Building Cost Impacts

(Contact us for applicable LEED credits by rating system for XLERATOR)

*XLERATOR clearly outperforms conventional dryers but how does it compare to paper towels?*

The results, as illustrated in the table and chart to the right, show that just on the basis of energy use electric hand dryers are far better, without even considering the many other environmental impacts of the manufacture and disposal of paper, including resource depletion, water pollution, and solid waste.

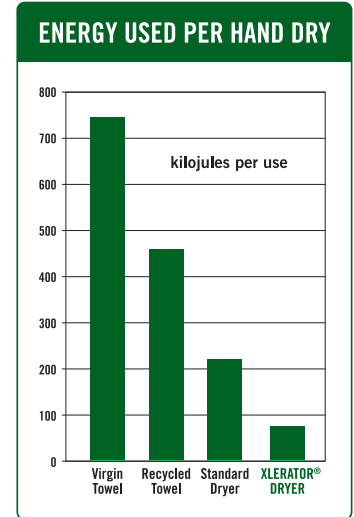

Description	Mj/kg	towels/kg	kW draw	time (sec)	kJ/use	Cost per 1,000 uses
Virgin Towel	131	352	--	--	743	\$23.00
Recycled Towel	81	352	--	--	460	\$23.00
Standard Dryer	--	--	2.2	30	222	\$1.47
XLERATOR® DRYER	--	--	1.5	15	76	\$0.50

\*The Leadership in Energy and Environmental Design (LEED®) Green Building Rating System™ is a/the nationally accepted benchmark for the design, construction, and operations of high performance green buildings.

LEED was developed by the U.S. Green Building Council (USGBC), a nonprofit working to transform the building industry to sustainable practices.

## XLERATOR is receiving a lot of attention...

### Awards

- Platinum Award for Excellence in Design (ADEX)
- Top Ten Green Product (Environmental Building News)
- Best Energy Savings Product (Electro Expo)
- Top Products Award (BOM Magazine)
- Innovator of the Year (California Restaurant Association)
- And many more...

### Featured Articles

THE WALL STREET JOURNAL • Sanitary Maintenance • Buildings  
Environmental Building News • American School and University  
Environmental Design and Construction • School Planning and Management

### Television Appearances



### What people are saying

*"I recently used the XLERATOR® hand dryer and was amazed! I have never liked hand dryers until I used the XLERATOR®."*

*"It is by far the best hand dryer I have ever used."*

*"I used the XLERATOR® and had the hand drying experience of a lifetime! AWESOME!"*

*"Get your XLERATOR® installed in more public restrooms - PLEASE!"*

# XLERATOR® Series **FINALLY... A FAST HAND DRYER!**



**Model XL-GR**  
Surface-mounted, Automatic,  
Graphite Textured Painted Cover

## Features

- 3 TIMES FASTER - Dries Hands in 10 to 15 Seconds
- Uses 80% Less Energy than other Hand Dryers
- 95% Cost Savings vs. Paper Towels
- Source Reduction Alternative
- Improves Hygiene in Restrooms



**Model XL-W**  
Surface-mounted,  
Automatic,  
White Epoxy  
Painted Cover

**Model XL-C**  
Surface-mounted,  
Automatic,  
Chrome  
Plated Cover

**Model XL-BW**  
Surface-mounted,  
Automatic,  
White Polymer  
(BMC) Cover

**Model XL-SB**  
Surface-mounted,  
Automatic,  
Brushed Stainless  
Steel Cover

**Model XL-SI\***  
Surface-mounted,  
Automatic,  
Custom Special  
Image Cover

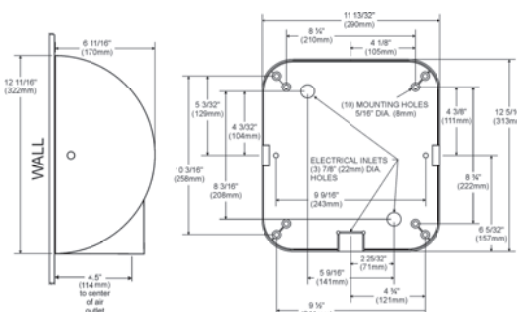

\*Note: Exclusive digital image technology allows for the addition of Company, School or Team logos with any color, design or a 'green message'

## SPECIFICATIONS

Dimensions: 11 3/4" lg. X 12 11/16" high X 6 11/16" deep (298 mm x 322 mm x 170 mm)  
Weight: XL-BW - 15 lbs. (6.80 kgs.) XL-SB 16 lbs. (7.26 kgs.)  
XL-W, XL-GR, XL-C, XL-SI - 17 lbs. (7.71 kgs.)

## Construction

- Cover shall be one of the following: **Die-cast zinc alloy** - One-piece, heavy-duty, rib-reinforced, lightweight, unbreakable, rustproof and all exposed surfaces shall be bright chrome plated or finished with chip-proof, electrostatically applied epoxy paint. **Bulk Molding Compound (BMC)** - White reinforced thermoset polymer. **Stainless Steel** - with a brushed finish. **Special Image** - Digital image applied to cover using patented Kolorfusion Sublimation Decoration process. All covers will be fastened to a wall plate by two chrome plated tamper-proof bolts.
- Wall plate shall be equipped with (3) 7/8" (22 mm) diameter holes, one of which shall be suitable for use with surface conduit, for ease of wiring.
- All internal parts shall be coated according to Underwriters' Laboratories, Inc. requirements.
- Entire mechanism shall be internally grounded.
- Optional recess kit includes a wall box (22 ga) and dryer mounting plate (16 ga) made from 18-8 Type 304 brushed stainless steel. A stainless steel tether is connected to the dryer mounting plate to hold the dryer in position when servicing.

## Mechanism

- Motor shall be a thermally protected, series commutated, through-flow discharge vacuum motor/blower (5/8 hp / 20,000 rpm) which provides air velocity of up to 19,000 lfm (linear feet per minute) at the air outlet and 16,000 lfm at the hands (4 inches [102 mm] below air outlet).
- Heating element (970 w) is constructed of Nichrome wire and mounted inside the blower housing, thereby being vandal proof. It shall be protected by an automatic resetting thermostat, which shall open whenever air flow is cut off and shall close when flow of air is resumed. It shall produce an air temperature of up to 135°F (57°C) at a 72°F (22°C) ambient room temperature at the hands (4 inches [102 mm] below air outlet).
- Control assembly is activated by an infrared optical sensor located next to the air outlet. The dryer shall operate as long as hands are under the air outlet. There is a 35-second lockout feature if hands are not removed.

## Limited Warranty

The dryer shall be guaranteed to be free from defects for a period of five (5) years. Warranty shall include labor performed at factory as well as the repair or exchange of defective parts, at manufacturer's option.

## Recess Kit - Meets ADA Protrusion Requirement of 4 inches (102 mm)

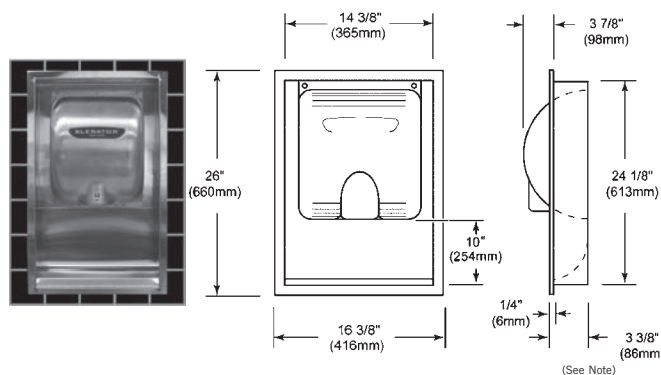

Dimensions: 16 3/8" wide x 26" high x 3 3/8" deep  
(416 mm wide x 660 mm high x 86 mm deep)  
Weight: 11 lbs. (4.99 kgs.)

Note: Bottom of recessed wall box should be 10 1/2" (27 cm) below suggested mounting height for dryer (see chart).

MODEL NO.	COVER FINISH	MOUNTING	TIME CYCLE	DRYER TYPE
XL-W	White	Surface	Automatic	Hand Dryer
XL-C	Chrome	Surface	Automatic	Hand Dryer
XL-GR	Graphite	Surface	Automatic	Hand Dryer
XL-BW	White Thermoset (BMC)	Surface	Automatic	Hand Dryer
XL-SB	Brushed Stainless Steel	Surface	Automatic	Hand Dryer
XL-SI	Special Image	Surface	Automatic	Hand Dryer

## Suggested Mounting Heights From floor to Bottom of Dryer

Men	45" (114 cm)
Women	43" (109 cm)
Teenagers	41" (104 cm)
Children	35" (89 cm)
Handicapped	37" (94 cm)

## Units are 1500 Watts and available as Specified in:

110/120V	12.5 Amp	60 hz
208V	7 Amp	60 hz
220/240V	6.5 Amp	50 or 60 hz
277V	5.5 Amp	60 hz

# CAST COVER Series

PUSH BUTTON ACTIVATED HAND AND HAIR DRYERS



**SURFACE MOUNTED**



**RECESSED MOUNTED**

Excel's Hands On® push button activated dryers lead the industry for quality and reliability. The Hands On series is engineered to provide twice the service free life of other dryers and is backed by a TEN YEAR UNLIMITED WARRANTY!



## Features

- Maintenance-free brushless motor, capacitor initiated for quick starts.
- Air nozzle revolves a full 360 degrees providing easy hand and face drying.
- Air nozzle can be fixed in a downward position by a simple on-sight adjustment.
- Covers are available in either a white epoxy paint or a chrome-plated finish.
- Custom colors also are available.
- All Hands On model dryers can also be specified to serve as hair dryers, ideal for health clubs, locker-room facilities, resorts and private washrooms.

### SURFACE MOUNTED MODEL NUMBERS

MODEL NO.	COVER FINISH	MOUNTING	TIME CYCLE	DRYER TYPE
76-W	White	Surface	30 seconds	Hand Dryer
76-C	Chrome	Surface	30 seconds	Hand Dryer
H76-W	White	Surface	3 minutes	Hair Dryer
H76-C	Chrome	Surface	3 minutes	Hair Dryer

### RECESSED MOUNTED MODEL NUMBERS

MODEL NO.	COVER FINISH	MOUNTING	TIME CYCLE	DRYER TYPE
R76-W	White	Recessed	30 seconds	Hand Dryer
R76-C	Chrome	Recessed	30 seconds	Hand Dryer
RH76-W	White	Recessed	3 minutes	Hair Dryer
RH76-C	Chrome	Recessed	3 minutes	Hair Dryer

SUGGESTED MOUNTING HEIGHTS FROM FLOOR TO BOTTOM OF DRYER					UNITS ARE AVAILABLE AS SPECIFIED IN:	
	Men	Women	Teenagers	Children		Handicapped
Hand Dryer	40" (102 cm.)	38" (97 cm.)	36" (91 cm.)	30" (76 cm.)	32" (81 cm.)	110/120V 15 or 20 Amp. 60 hz 208/230V 10 Amp. 60 hz 277V 8 Amp. 60 hz
Hair Dryer	64" (163 cm.)	58" (147 cm.)	56" (142 cm.)	43" (109 cm.)	45" (114 cm.)	220/240V 10 amp. 50 hz

### SPECIFICATIONS

#### Construction

- Dryer cover shall be one-piece, heavy-duty, rib-reinforced die-cast zinc alloy. It shall be lightweight, unbreakable, rust-proof, fitted with a chrome plated die-cast zinc alloy push button, a fixed or 360° revolving die-cast, chrome plated, zinc alloy nozzle.
- All exposed surfaces shall be bright chrome plated or finished with chip-proof, electrostatically applied epoxy paint.
- Surface-mounted covers shall be fastened by two flat head, recessed tamper-proof bolts to a cast zinc alloy wall pallet and shall be equipped with three (3) 7/8" (22mm) diameter holes, one of which shall be suitable for use with surface conduit. Recessed covers shall be fastened by four flat-head recessed, tamper-proof bolts to wall box and shall be equipped with two (2) 7/8" (22mm) diameter holes for ease of wiring. Wall plate shall be fastened to wall box by four concealed 1/4" (6mm) mounting bolts.
- Cover shall be equipped with an air inlet opening on the bottom of the casting and covered with a vandal resistant metal protective grill to prevent the entry of foreign objects. A chrome plated air outlet nozzle on the front of the cover shall permit a full flow of warm air when in operation, and shall be protected by a cast alloy grating fixed into the blower housing.
- All internal parts shall be coated according to Underwriters' Laboratories, Inc. requirements.
- Entire mechanism shall be internally grounded.

#### Mechanism

- Motor shall be capacitor-initiated, brushless type (for longer life and quiet operation) 1/10 hp, 3450 rpm with self-lubricated bearings. It shall be insulated

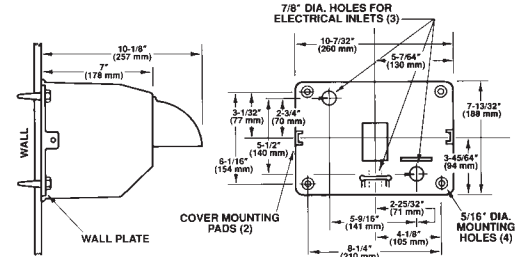

#### SURFACE MOUNTED

Dimensions: 10 3/4 lg. x 8" high x 7" deep (273 mm x 203 mm x 178 mm)  
Weight: 17 lbs. (7.7 kgs.)

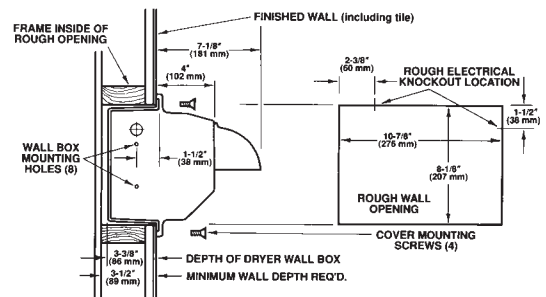

#### RECESSED MOUNTED

Dimensions: 12 1/2 lg. x 9 3/4 high x 4" deep (318 mm x 248 mm x 102 mm)  
Weight: 18 lbs. (8.1 kgs.)

- by a resilient mounting and shall be protected by a self-resetting thermal protector. For 50 hz applications, motor shall be a universal 1/10 hp, 4200 rpm at rated load, with sealed lubricated ball bearings. Motor shall be insulated by resilient mounting and is thermally protected.
- Fan shall be a large, single inlet centrifugal type for maximum capacity, and shall deliver 150 cfm. Fan shall be mounted directly on the motor shaft, and fan and motor unit shall be insulated from dryer with a resilient rubber mounting to obtain maximum dampening effect.
- The heating element is constructed of Nichrome wire and side mounted on the blower housing, thereby being vandal proof. It shall be protected by an automatic resetting thermostat which shall open whenever air flow is cut off and shall close when flow of air is resumed. The element shall produce an air temperature of 145°F/63°C at a 72°F/22°C ambient room temperature at the outlet.
- The timer is a state of the art electronic device with an adjustable time cycle. For hand dryers, timers are set at 30 seconds and at 3 minutes for hair drying.

#### Unlimited Warranty

All parts on Hand and Hair Dryers shall be warranted against defective material and/or workmanship for a period of ten years. Warranty shall include labor performed at factory as well as the repair or exchange of defective parts at manufacturer's option, and shall include damage due to accidents, misuse or vandalism.

# CAST COVER Series AUTOMATIC SENSOR ACTIVATED HAND DRYERS



**SURFACE MOUNTED**



**RECESSED MOUNTED**

Excel's Hands Off hand dryers provide exceptionally quiet operation with maximum strength and durability. Performance is backed by a 10 Year Limited Warranty on the dryer (5 years on the control assembly and sensor). Surface mounting or recessed mounting options are available.

## Features

- Fully Automatic – Dryers are activated by an infrared sensor
- Maintenance-free brushless motor, capacitor initiated for quick starts.
- Vandal-proof – Features include tamper-proof bolts and a side-mounted heating element inaccessible through the air outlet.
- Covers are available in either a white epoxy paint or a chrome-plated finish.
- Custom colors also are available.



## SURFACE MOUNTED MODEL NUMBERS

MODEL NO.	COVER FINISH	MOUNTING	TIME CYCLE	DRYER TYPE
HO-IW	White	Surface	Automatic	Hand Dryer
HO-IC	Chrome	Surface	Automatic	Hand Dryer

## RECESSED MOUNTED MODEL NUMBERS

MODEL NO.	COVER FINISH	MOUNTING	TIME CYCLE	DRYER TYPE
R76-IW	White	Recessed	Automatic	Hand Dryer
R76-IC	Chrome	Recessed	Automatic	Hand Dryer

SUGGESTED MOUNTING HEIGHTS FROM FLOOR TO BOTTOM OF DRYER						UNITS ARE AVAILABLE AS SPECIFIED IN:	
	Men	Women	Teenagers	Children	Handicapped	110/120V	15 or 20 Amp. 60 hz
Surface	43" (109 cm.)	41" (104 cm.)	39" (99 cm.)	33" (84 cm.)	35" (89 cm.)	208/230V	10 Amp. 60 hz
Recessed	40" (102 cm.)	38" (97 cm.)	36" (91 cm.)	30" (76 cm.)	32" (81 cm.)	277V	8 Amp. 60 hz
						220/240V	10 amp. 50 hz

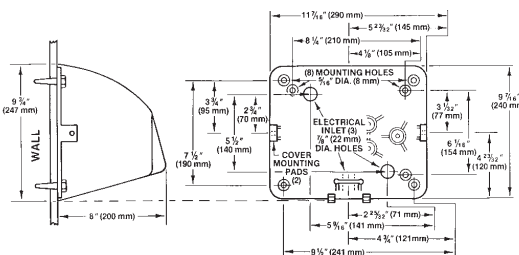

### SURFACE MOUNTED

Dimensions: 12 lg. x 9 3/4" high x 8" deep (305 mm x 248 mm x 203 mm)  
Weight: cast 16 lbs. (7.2 kgs.)

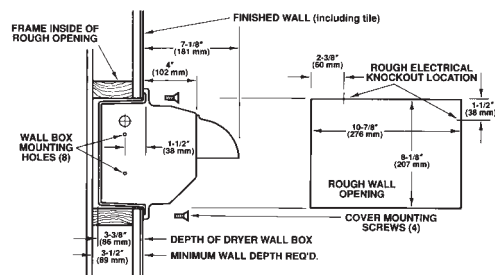

### RECESSED MOUNTED

Dimensions: 12 1/2 lg. x 9 3/4" high x 4" deep 318 mm x 248 mm x 102 mm  
Weight: 18 lbs. (8.1 kgs.)

## SPECIFICATIONS

### Construction

A. Dryer Cover HO-IW & HO-IC Models: shall be one piece, heavy-duty, rib-reinforced die-cast zinc alloy. It shall be lightweight, unbreakable, rustproof and all exposed surfaces shall be bright chrome plated or finished with chip-proof, electrostatically applied epoxy, and fastened by two chrome plated tamper-proof bolts to a cast zinc alloy wall plate.

R76-IW & R76-IC Models: shall be one piece, heavy-duty, rib-reinforced die-cast zinc alloy. It shall be lightweight, unbreakable, rustproof and all exposed surfaces shall be bright chrome plated or finished with chip-proof, electrostatically applied epoxy, fitted with a fixed, die-cast, chrome plated, zinc alloy nozzle.

B. The wall plates for surface mounted models shall be equipped with (3) 7/8" (22 mm) diameter holes one of which shall be suitable for use with surface conduit, for ease of wiring.

Recessed covers shall be fastened by four flat-head, recessed, tamper-proof bolts to wall box. Wall plate shall be fastened to the wall box by four concealed 1/4" (6mm) mounting bolts, and shall be equipped with two knockouts for ease of wiring.

C. HO-IW & HO-IC Models: shall have a chrome plated, die-cast zinc air outlet which shall be fixed to the blower housing and shall be of a design that will not allow foreign objects to enter the dryer. R76-IW & R76-IC Models: shall be equipped with an air inlet opening on the bottom of the casting and covered with a vandal resistant metal protective grill to prevent the entry of foreign objects. A fixed chrome plated, die-cast zinc air outlet nozzle on the front of the cover shall permit a full flow of warm air when in operation, and shall be protected by a cast alloy grating fixed into the blower housing.

D. All internal parts shall be coated according to Underwriters' Laboratories, Inc. requirements.

E. Entire mechanism shall be internally grounded.

### Mechanism

A. Motor shall be capacitor-initiated, brushless type (for longer life and quiet operation) 1/10 hp, 3450 rpm with self-lubricated bearings. It shall be insulated by a resilient mounting, and shall be protected by a self-resetting thermal protector. For 50 hz applications, motor shall be a universal 1/10 hp, 4200 rpm at rated load, with sealed lubricated ball bearings. Motor shall be insulated by a resilient mounting and is thermally protected.

B. Fan shall be a large, single inlet centrifugal type for maximum capacity, and shall deliver 180 cfm (150 cfm for Recessed Model) Fan shall be mounted directly on the motor shaft, and fan and motor unit shall be insulated from dryer with a resilient rubber mounting to obtain maximum dampening effect.

C. The heating element is constructed of Nichrome wire and side mounted on the blower housing, thereby being vandal proof. It shall be protected by an automatic resetting thermostat, which shall open whenever air flow is cut off and shall close when flow of air is resumed. It shall produce an air temperature of 145°F/63°C at a 72°F/22°C ambient room temperature at the outlet.

D. The control assembly is activated by an infrared optical sensor located next to the air outlet. The dryer shall operate as long as hands are moving under the air outlet. There is a 60 second lockout feature, if hands are not removed.

### Limited Warranty

The dryer shall be guaranteed to be free from defects for a period of ten years, except for five years on the control assembly and sensor. Warranty shall include labor performed at factory as well as the repair or exchange of defective parts, at manufacturer's option.

# LEXAN Series AUTOMATIC AND PUSH BUTTON HAND DRYERS



**AUTOMATIC SENSOR**



**PUSH BUTTON**

Combine Excel's reputation of superior performance with the economic benefit of this dryer series and get maximum value for your investment!



## Features

- Economical – The cost of energy to operate a dryer is less than 10% of the cost of paper towels. In addition, the following costs are eliminated: ordering, storing, replenishing dispensers, collecting, and disposing of paper towels.
- Maintenance-free brushless motor, capacitor initiated for quick starts.
- Durable Construction – These surface mounted dryers are constructed with a one-piece molded Lexan cover.
- Style Options – Select from either the traditional push button activated or the automatic sensor activated models.
- Vandal Proof – Features include tamper-proof bolts and a side mounted heating element inaccessible through the air outlet.

### SPECIFICATIONS

#### Construction

- Cover shall be a one-piece molded Lexan® 940, with the color uniformly throughout and fastened by two chrome-plated tamper-proof bolts to a cast zinc alloy wall plate.
- Wall plate shall be equipped with (3) 7/8" (22 mm) diameter holes. one of which shall be suitable for use with surface conduit. for ease of wiring,
- Dryers shall have a chrome-plated, die-cast zinc blower vent/grill (air outlet) which shall be fixed to the blower housing and shall be of a design that will not allow foreign objects to enter the dryer.
- All internal parts shall be coated according the Underwriters Laboratories, Inc.
- Entire mechanism shall be Internally grounded.
- HO-BL Model: Includes a chrome-plated push button assembly mounted onto front of cover.

#### Mechanism

- Motor shall be capacitor-initiated, brushless type (for longer life and quiet operation) 1/10 hp, 3450 rpm with self-lubricated bearings. It shall be insulated by a resilient mounting, and shall be protected by a self-resetting thermal protector. For 50 hz applications, motor shall be a universal 1/10 hp, 4200 rpm at rated load, with sealed lubricated ball bearings. Motor shall be insulated by a resilient mounting and is thermally protected.
- Fan shall be a large, single inlet centrifugal type for maximum capacity and shall deliver a minimum of 180 cfm Fan shall be mounted directly on the motor shaft, and fan and motor unit shall be insulated from dryer with a resilient rubber mounting to obtain maximum sound and vibration dampening effect
- The heating element of Nichrome wire shall be side mounted on the intake, thereby being vandal proof. It shall be protected by an automatic resetting circuit breaker (25 Amp). which shall open whenever air flow is cut off and shall close when flow of air is resumed. It shall produce an air temperature of approximately 145°F (63°C) at 72°F (22°C) ambient room temperature at the outlet.
- HO-IL Model: A control assembly is activated by an infrared optical sensor located next to the air outlet. The dryer shall operate as long as hands are under air outlet with a lockout of approximately 60 seconds if hands are not removed. HO-BL Model: A sealed electronic timer will operate the hand dryer for 30 seconds after push button actuation.

#### Limited Warranty

The dryer shall be guaranteed to be free of defects for a period of five (5) years. Warranty shall include labor performed at factory, as well as the repair or exchange of parts at manufacturer's option.

see us at  
**Sweets.com**

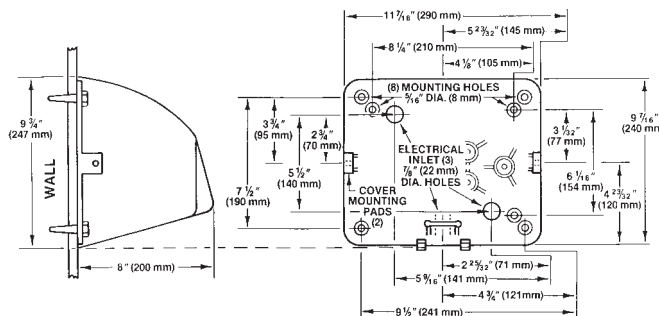

Dimensions: 12" long x 9 3/4" high x 8" deep-, (305 mm x 248 mm x 203 mm)  
Weight: 13 lbs. (5.9 kgs.)

### SUGGESTED MOUNTING HEIGHTS FROM FLOOR TO BOTTOM OF DRYER

Men's	Ladies	Teenagers	Children's	Handicapped
43" (109 cm.)	41" (104 cm.)	39" (99 cm.)	33" (84 cm.)	35" (89 cm.)

MODEL NO.	COVER FINISH	MOUNTING	TIME CYCLE	DRYER TYPE
HO-BL	Lexan®	Surface	30 seconds	Hand Dryer
HO-IL	Lexan®	Surface	Automatic	Hand Dryer

#### UNITS ARE AVAILABLE AS SPECIFIED IN:

110/120V	15 or 20 Amp.	60 hz
208/230V	10 Amp.	60 hz
277V	8 Amp.	60 hz
220/240V	10 amp.	50 hz



## EXCEL DRYER Inc.

357 Chestnut Street · P. O. Box 365  
East Longmeadow, MA 01028 (USA)  
Tel: 1.413.525.4531 Fax: 1.413.525.2853  
Email: [sales@exceldryer.com](mailto:sales@exceldryer.com)  
Web: [www.exceldryer.com](http://www.exceldryer.com)