

13 24 16/FIN
BuyLine 2663

The Sauna's
Natural Beauty
Begins in
the Majestic
Western Forest ...

FINLANDIA THE PACESETTERS
& HARVIA SAUNAS

... and Lingers in
the Soothing
Warmth of
the Bathing
Environment

see us at
Sweets.com



Sauna Q&A... From the Sauna Experts

HOW IS A SAUNA DIFFERENT FROM OTHER BATHS?

A Sauna must have a special, insulated room built of softwood; a heater which is designed and built to heat the room to a temperature of about 180°F when thermometer is placed 6" down from ceiling over Sauna heater; and stones which get hot (about 500-700°F) to produce a good steam when water is poured over them. Anything else is NOT A SAUNA!

IS A SAUNA A STEAMBATH?

A Sauna is not a steambath, but a Sauna is superior to a steambath for opening pores and ridding the body of impurities. As humidity is increased to only about 25% when water is poured over the stones, the air is still dry. There is no possibility of water condensation to cause damage to the surrounding areas of the Sauna room—peeling of wallpaper or paint—and there is no chance of dry rot. In contrast, a steambath has 100% humidity.

ARE ROCKS NECESSARY IN A SAUNA?

Rocks are necessary to store heat and to produce steam when water is poured over them. Heaters that do not heat rocks (such as Infrared heaters) are not Sauna heaters.

SHOULD ROCKS BE DIRECTLY HEATED?

Rocks must be distributed *among* the electric elements in the heater so that they will get hot enough to produce a good steam and so that they will filter the heat for a comfortable Sauna. Rocks which sit on top of a grille or basket will not produce as good a steam and the bather will experience a harsh heat, because the heat reflects directly off the elements.

WHY IS WATER NECESSARY IN A SAUNA?

Bathers can regulate their own humidity to create a more relaxing atmosphere and to aid perspiration and deep cleansing of the pores. One or two dipperfuls of water are ladled slowly over the hot stones as often as the bather chooses.

WHY MUST A SAUNA BE BUILT OF SOFTWOOD?

The humidity must be absorbed to keep the atmosphere dry. Softwoods have this property. Hardwoods absorb heat and become too hot to sit or lean against. The wood must be kiln dried to within 6-11% moisture content to prevent shrinkage and warpage.

WHY IS THE THICKNESS OF THE WALL AND CEILING PANELING IMPORTANT IN THE SAUNA?

The thicker the lumber and the more growth rings per inch, the less chance there is of

shrinkage. 1" x 4" and 1" x 6" material (with $\frac{1}{16}$ " finished thickness) will not shrink as much as $\frac{1}{2}$ " x 4" or $\frac{1}{2}$ " x 6" material. FINLANDIA uses 1" x 4" lumber for the interior of the Sauna.

SHOULD YOU USE KNOTTY WOOD IN THE SAUNA?

Even when using the highest grade of knotty wood (construction grade) knots can crack during the kiln drying process; knots can loosen in the high Sauna heat, leave ugly holes, and seep pitch; and the bather can be burned when touching hot knots. FINLANDIA does not use knotty woods. They are cheaper and inferior to our clear softwoods.

SHOULD A SAUNA HAVE A WATERPROOF FLOOR?

A Sauna must have a waterproof floor so that it can be easily washed and kept clean and sanitary, and free of odor. Best washable floors are cement, tile (and tile is strongly recommended), or vinyl. In new construction, we also recommend a drain where possible (very important in commercial Saunas!)

SHOULD A SAUNA BE INSULATED?

Yes, to prevent heat loss. We recommend R11 fiberglass batt type of insulation between the framing of the walls and ceiling.

HOW HIGH SHOULD A SAUNA BE?

Sauna ceiling height should be no higher than 7' as it is important to bring the heat down to the bench levels. It is also more economical to heat, and the Sauna will heat faster.

WHERE CAN A SAUNA BE INSTALLED?

ANYWHERE, but it is best to have it close to a shower for convenience (for cooling off and washing off purposes).

WHO CAN USE A SAUNA?

Any healthy person of any age can safely use a Sauna. People with health risks should consult their physicians before using a Sauna.



FPC CUSTOM 1" X 4" WESTERN RED CEDAR, STANDARD HORIZONTAL WALL BOARDS, OPTIONAL SKIRT AND BACKREST.



FPC WITH STANDARD HORIZONTAL BOARDS AND STANDARD CLEAR GLASS DOOR, INSTALLED IN CUSTOM LOCATION.

IS A SAUNA EXPENSIVE TO OPERATE?

Heat up time is fast—20 to 30 minutes—and the Sauna is only on when being used. The average FINLANDIA home Sauna costs as little as \$3 per month to operate, when used 3 times a week.

Finlandia/Harvia Heaters

13 24 16/FIN
BuyLine 2663

The heart of any Sauna is the Sauna heater, and FINLANDIA and HARVIA heaters are the "best of the best." These authentic Sauna heaters are noted for their superior quality and performance. FINLANDIA and HARVIA heaters also have:

STAINLESS STEEL ELEMENTS for long life.

STAINLESS STEEL INTERIOR

LARGE ROCK CAPACITY for heat storage.

DIRECT ROCK CONTACT WITH HEATING ELEMENTS—necessary to: filter the harsh heat radiating from the 1400 degree elements so the bather feels only pleasant, soft heat; produce the best steam when water is poured over them to create the proper Sauna climate; and, retain heat so there is less off/on cycling of the heater for heating efficiency and economy.

FREE AIR FLOW for faster heating.

MAXIMUM STRENGTH AND DURABILITY from pressed metal design.

Note: When ordering, specify the elevation above sea level at your location. If a fire sprinkler is required, the head should be set at 275°F (or higher) and should not be located over the Sauna heater.

Model FLB/KIP-B

Wall mounted. Size: 16" w x 11" d x 24" h. Built-in controls (60 min. timer, thermostat). **Exclusive:** 1-8 hr. programmable time clock allows Sauna to be preset up to 8 hrs. in advance. Controls can also be side mounted. **Stainless steel** interior, top; baked enamel exterior.



MODEL FLB

MODEL KIP-B

MODEL FLB FINLANDIA/MODEL KIP-B HARVIA									
HEATER MODEL NO.	MIN.-MAX. CU. FT. SAUNA ROOM	WATTS	AMPS	VOLTAGE	PHASE	WIRE SIZE 90°C COPPER	CONTROL MODEL NO.	CONTACTOR MODEL NO.	SHIPPING WEIGHT
FLB30	84-130	3,000	12.5	240	1	12	Built-in	None	40
FLB45	100-210	4,500	18.8	240	1	10	Built-in	None	40
FLB60	170-300	6,000	25	240	1	10	Built-in	None	40
FLB80	250-425	8,000	33.3	240	1	8	Built-in	None	40

50# PERIDOTITE STONES SHIPPED IN SEPARATE BOX.

MODEL FIN FINLANDIA/MODEL KIP-W HARVIA									
HEATER MODEL NO.	MIN.-MAX. CU. FT. SAUNA ROOM	WATTS	AMPS	VOLTAGE	PHASE	WIRE SIZE 90°C COPPER	CONTROL MODEL NO.	CONTACTOR MODEL NO.	SHIPPING WEIGHT
FIN30	84-130	3,000	12.5	240	1	12	F1T	None	40
FIN45	100-210	4,500	18.8	240	1	10	F1T	None	40
FIN60	170-300	6,000	25	240	1	10	F1T	None	40
FIN80	250-425	8,000	33.3	240	1	8	F2T	FL402	40
FIN30-3	84-130	3,000	8.3	208	3	14	F2T	FL303	40
FIN45-3	100-210	4,500	12.5	208	3	14	F2T	FL303	40
FIN60-3	170-300	6,000	16.7	208	3	12	F2T	FL303	40
FIN80-3	250-425	8,000	22.2	208	3	10	F2T	FL303	40

50# PERIDOTITE STONES SHIPPED IN SEPARATE BOX.

Finlandia and Harvia Sauna heaters have 3-wall construction for cooler surface temperature and greater safety.

 All Finlandia and Harvia Sauna heaters are UL tested and listed.

HEATER GUARD ASSEMBLY

For safety, each Sauna heater should have a 2- or 3-sided wood guardrail that is mounted on the wall 2" to 2 1/2" from the heater. Finlandia wall mounted heaters need a 15" x 25" guardrail and floor models need a 30" x 30" guardrail. These dimensions satisfy the minimum requirements for heater clearance from wall surfaces.



Exclusive Option

A Finlandia exclusive; **Stainless steel**—interior and exterior. Available in FLB or FIN models. Recommended for commercial installations (health clubs, hospitals, military installations, coastal areas with salty air, etc.).

Model FIN/KIP-W

Wall mounted. Size: 16" w x 11" d x 24" h. Uses wall control and contactor. **Stainless steel** interior, top; baked enamel exterior.



MODEL FLB-S OR FIN-S



MODEL FIN

MODEL KIP-W

...The Pacesetters

13 24 16/FIN
BuyLine 2663

MODEL FLC FINLANDIA/MODEL K HARVIA									
HEATER MODEL NO.	MIN.-MAX. CU. FT. SAUNA ROOM	WATTS	AMPS	VOLTAGE	PHASE	WIRE SIZE 90°C COPPER	CONTROL MODEL NO.	CONTACTOR MODEL NO.	SHIPPING WEIGHT
FLC90	300-525	9,000	37.5	240	1	6	F2T	FL404	60
FLC105	390-600	10,500	43.8	240	1	6	F2T	FL404	60
FLC120	440-750	12,000	50	240	1	4	F2T	FL404	60
FLC150	560-1050	15,000	62.5	240	1	4	F2T	FL404	60
FLC90-3	300-525	9,000	25	208	3	10	F2T	FL503	60
FLC105-3	390-600	10,500	29.2	208	3	8	F2T	FL503	60
FLC120-3	440-750	12,000	33.3	208	3	8	F2T	FL503	60
FLC150-3	560-1050	15,000	41.7	208	3	8	F2T	FL503	60

100# PERIDOTITE STONES SHIPPED IN 2 SEPARATE BOXES.

Woodburning Sauna Stoves from Finland

Ideal for remote areas with no adequate electricity, the stove is manufactured by the largest woodburning Sauna stove factory in Finland. Shipping weight is 132 lbs. plus 100 lbs. of igneous stones. Ideal for rooms 6' x 8' to 8' x 10' with ceiling height 7' or 8'. Stoves include adapter which converts metric pipe size to standard 6" pipe size.

HARVIA 20 SUPER

Size: 17" w x 20" d x 29" h.
Galvanized metal—red and black.

HARVIA 20ES

Size: 17" w x 24½" d x 29" h.
With 5 gal. water tank inside top front.

HARVIA 20ST

Size: 17" w x 20" d x 29" h.
Stainless steel and black galvanized metal.

WOOD STOVE SURROUND

For any of our wood stoves.
Galvanized metal—3 walls and floor.
Ext. dimensions: 22" w x 34" d x 40½" h.
Int. floor dimensions: 19½" w x 31½" d x 2" h.
(with adjustable leg leveler)



SAUNA HEATERS MUST BE ENGINEERED FOR DIRECT HEATING

Finlandia Sauna heaters have directly heated stones that completely cover the electric elements, to filter the harsh heat and eliminate the electro-magnetic field for safe and therapeutic bathing. Our heaters are tested and designed for that perfect combination of stone quantity, proper airflow, and steam output. Some heaters have too many stones in the heater cavity. This reduces the natural airflow and increases the heating time and cost of operation.

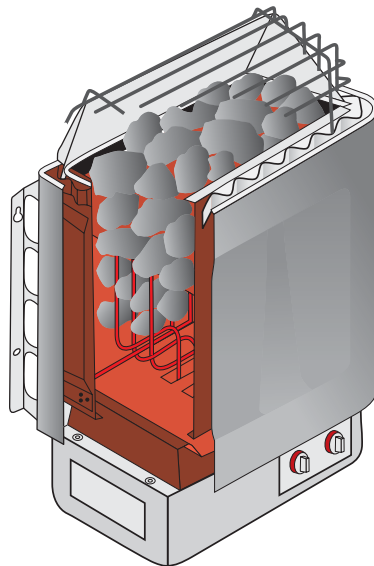

HEATER STONES ARE EVENLY DISPERSED AMONG THE HEATER ELEMENTS FOR FREE AIRFLOW AND BEST STEAM OUTPUT.

Model FLC/K

Floor model.
Size 17" w x 20" d x 26" h.
Deluxe stainless steel interior and exterior.
Uses wall control and contactor.



F1T AND F2T CONTROL



CONTACTOR

FINLANDIA CONTROLS

F1T and F2T controls include: thermostat, 60 min. timer, light switch, and indicator light. Made in U.S.A.

F2 control does not include a 60 min. timer. It can be used with any of the above heaters, with contactor, and with use of a 24 hr. time clock.

F1T 3¾" w x 9¼" h x 3½" d.

F2T & F2 3¾" w x 9¼" h x 2½" d.

FINLANDIA CONTACTORS

See charts on pages 4 and 5 for use with proper heater and control. Made in USA.

FL402 & FL303 6" w x 8" h x 4" d.

FL404 & FL503 8" w x 12" h x 4" d.

...The New Generation of Sauna Heaters

Compact JM

This compact 110V-220V Sauna heater is a space saver in a small room. Measuring only 12" wide x 9" deep x 25" high, it has the only built-in heater fence in the industry. Unlike other heaters of its size which are light weight, the Compact has heavy-duty deluxe stainless steel construction—interior and exterior—for strength and durability. Other unique features are a lighted control panel at the top of the heater for easy and safe operation—it can be interchanged to left or right side of heater—and a removable tray which is attached to the bottom of the heater to catch excess water and prevent leakage of water to the floor.



MODEL JM										
HEATER MODEL NO.	MIN.-MAX. CU. FT. SAUNA ROOM	WATTS	AMPS	VOLTAGE	PHASE	WIRE SIZE 90°C COPPER	CONTROL MODEL NO.	CONTACTOR MODEL NO.	DIM. DxWxH	SHIPPING WEIGHT
JM 17	42-64	1,700	14.2	120	1	12	Built-in	None	9x12x25	47
JM 20	44-79	2,000	16.6	120	1	12	Built-in	None	9x12x25	47
JM 30	68-138	3,000	12.5	240	1	12	Built-in	None	9x12x25	47

21# PERIDOTITE STONES INCLUDED IN SHIPPING WEIGHT—SAME BOX.

MODEL KV										
HEATER MODEL NO.	MIN.-MAX. CU. FT. SAUNA ROOM	WATTS	AMPS	VOLTAGE	PHASE	WIRE SIZE 90°C COPPER	CONTROL MODEL NO.	CONTACTOR MODEL NO.	DIM. DxWxH	SHIPPING WEIGHT
KV 45	100-210	4,500	18.8	240	1	10	Built-in	Built-in	10x18x25	41
KV 60	170-300	6,000	25	240	1	10	Built-in	Built-in	10x18x25	43
KV 80	250-425	8,000	33.3	240	1	8	Built-in	Built-in	10x18x25	44

50# PERIDOTITE STONES SHIPPED IN SEPARATE BOX. 4# ROCK GUARD SHIPPED IN SEPARATE BOX.

MODEL AV										
HEATER MODEL NO.	MIN.-MAX. CU. FT. SAUNA ROOM	WATTS	AMPS	VOLTAGE	PHASE	WIRE SIZE 90°C COPPER	CONTROL MODEL NO.	CONTACTOR MODEL NO.	DIM. DxWxH	SHIPPING WEIGHT
AV 4	170-300	4,400	18.3	240	1	10	Built-in	None	21x20x37	91
AV 6	200-400	6,500	27	240	1	8	Built-in	None	21x20x37	91

250# PERIDOTITE STONES SHIPPED IN 5 SEPARATE BOXES.

Topclass KV

This top-of-the-line wall-mounted heater is engineered for the 21st century. The lighted control panel is designed for simplicity and ease of usage and it is reversible—left or right side—with a 60 minute timer and a delayed 8 hour time clock. With stainless steel interior and exterior and high tech engineering, the Topclass is the most heavy duty of any wall mounted heater in the industry and it is manufactured for longest life.



Ever Ready AV

Forget about planning, advance programming, and heating times! Made for the fast paced American lifestyle, this high tech Sauna heater offers a breakthrough in Sauna heating. There is no 30 minute heat up time—the Sauna is ready when you are! Thanks to microceramic insulating technology (similar to that used in the space program), and an extremely large stone capacity, the Ever Ready stores thermal energy, and with its basic power of 250 watts, the heater is ready instantly. One can go into the Sauna, pop open the heater lid, turn on the venturi action vent, and instantly enjoy the softest heat and outstanding steam production. Also, a 1 hour booster can be switched on for those who like a very hot Sauna! The Ever Ready consumes only the same amount of energy as three 75 watt light bulbs. Ideal for home use, the heater needs no fence because it has the coolest casing of any Sauna heater on the market. Caution! This Sauna heater is habit forming! Platinum and stainless finish as shown.



Comfort Control Unit

This ultramodern control unit has an illuminated panel which lights up when the heater is operating. All of the "new generation" heaters have this control. (JM, KV, AV).

Note! All of these heaters are residential models only.

Finlandia Precut Sauna Packages (FPC)

You frame and insulate, and we furnish interior parts only.

We have built our reputation as "old country" Sauna builders since 1964, by believing that it takes individual attention to provide each customer with a quality piece of workmanship. Our FINLANDIA Sauna packages are custom cut with special care and experienced craftsmanship. It's the little extras that count—so we take the extra effort—such as nailing our benches from the bottom to make sure that our customers will have no worries (or burns) from protruding nails. We countersink any surface nails, and we fill any visible nail holes.

Note: In preparation for our FPC package, frame and insulate your space and follow general contractor specifications on page 12. Only standard carpentry skills are needed for installation.

FPC Packages Include PRECUT WALL & CEILING BOARDS

1" x 4" clear, certified, kiln-dried, T&G boards, cut to length of wall and ceiling for horizontal installation. Choice of 4 woods.



1" X 4" CLEAR WESTERN RED CEDAR



1" X 4" CLEAR REDWOOD



1" X 4" CLEAR WESTERN HEMLOCK



1" X 4" CLEAR ALASKA YELLOW CEDAR STANDARD FPC FINLANDIA PRECUT PACKAGE IN WESTERN RED CEDAR.



BOARDS ARE CUT FOR HORIZONTAL INSTALLATION. BACKRESTS ARE OPTIONAL.

ASSEMBLED BENCHES of clear V.G. S4S kiln-dried 2"x2" tops with 1/2" spacing, and 2"x4" facing (much superior to standard 1"x3" lightweight benches, in design and strength). See pg. 11 also.

PREHUNG GLASS DOOR (FGD) 2'0" x 6'8" as per specs page 8.

Interior casing ONLY.

ASSEMBLED HEATER FENCE

ASSEMBLED HEADREST/BACKREST for upper bench(es).

TRIM AND BASE

SUPER DEK as per specs page 11 and 12 (enough for walking area of floor).

FINLANDIA OR HARVIA HEATER PERIDOTITE STONES

CONTROL/CONTACTOR PANEL (if required by heater).

LIGHT wall mounted, vapor-proof.

VENTS (two sets) for installation in upper and lower wall areas.

ACCESSORIES wooden thermometer #0301K, bottomless wooden bucket with plastic liner #102N, wooden dipper #106/40, bathing sign.

TYPE C BUILDING FOIL

INSTRUCTIONS for building.

NAILS hot dipped, galvanized, 5p.

Sizes shown are examples only. We can cut to any custom size.

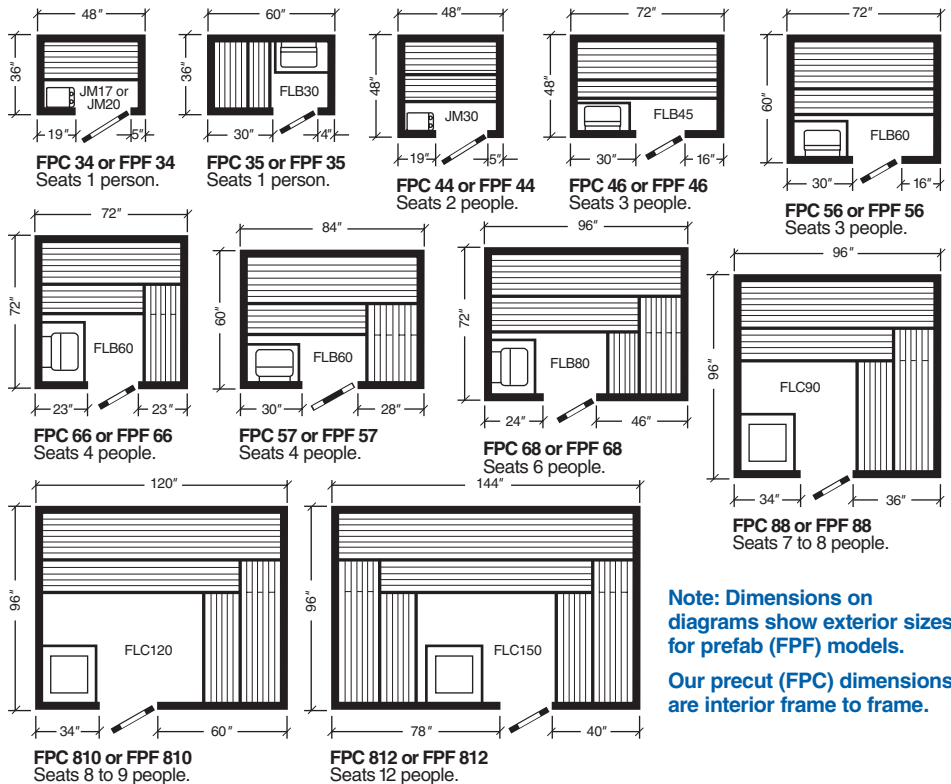

Note: Dimensions on diagrams show exterior sizes for prefab (PPF) models.

Our precut (FPC) dimensions are interior frame to frame.

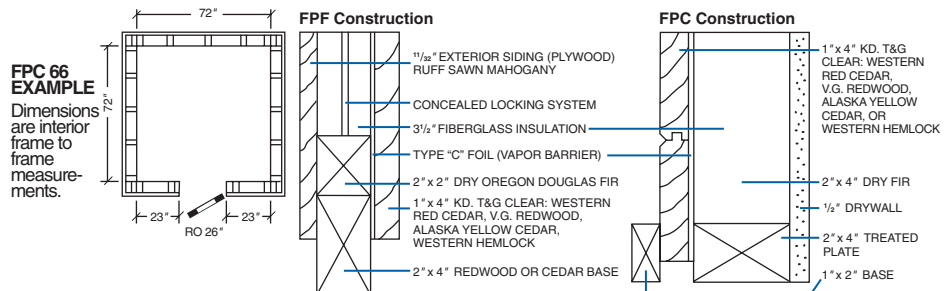

Finlandia Prefab Modular Saunas (FPF)

Free-standing units include interior and exterior.

Made in the USA.



OUR UNIQUE LOCKING SYSTEM GUARANTEES FASTEST AND EASIEST ASSEMBLY, STRONGEST INSTALLATION, AND MOST CUSTOM LOOK. FPF IS SHOWN WITH WESTERN RED CEDAR INTERIOR.

Our prefab Saunas are engineered with effortless and fast installation in mind, and can be installed on any hard-surfaced, waterproof floor. Our unique interlocking design makes other modular systems obsolete by comparison. Electrical hookup is made easy because all electrical conduit is sealed within walls, and control box (where necessary) is premounted. Engineered for highest economy, with an R value of 13.5 (exceeding other modular Saunas on the market) our prefabs are also designed with 2 vents to allow a natural exchange of air, for comfort and good oxygen supply for the bather. Our FINLANDIA prefabs are not only designed for best function and eye appeal, but are manufactured with “old country” craftsmanship—we craft each room like a fine piece of Scandinavian furniture.

FPF Saunas Include

FRAMING of 2" x 2" Oregon Douglas Fir to prevent warpage and dry rot. Frame fastened with galvanized fasteners.

INSULATION — R11 (3½") Fiberglass batts—walls and ceiling.

VAPOR BARRIER—type C Building Foil on walls and ceiling.

BASE of 2" x 4".

EXTERIOR SIDING of 1½" ruff-sawn mahogany plywood. (Option—½" x 4" T&G Western Red Cedar.)

INTERIOR PANELING walls and ceiling of 1" x 4" clear, kiln-dried, T&G small v joint for neat appearance—choice of clear Redwood, clear Western Red Cedar, clear Alaska Yellow Cedar, and clear Western Hemlock.

EXCLUSIVE CONCEALED LOCKING SYSTEM locks walls together with greatest strength and neatest appearance (eliminates need for ugly interior moldings—used by others).

BENCHES constructed of S4S 2" x 2" tops with ½" spacing, S4S 2" x 4" facing with eased edges to eliminate sharp angles and splinters; all fasteners are applied from bottom to eliminate ugly nail holes and the danger of nails popping up to burn bather.

HEAD/BACK REST(s) for upper bench(es); tapered 16" x 20".

See page 6 for some of the standard sizes available.

PREHUNG DOOR — V.G. Oregon Douglas Fir rails to prevent warpage, tempered, thermopane glass unit for spacious open look, fir or Hemlock jamb, stoppers, casing and threshold; hardware — (3) 4" x 4" butt hinges (chrome plated), ball catch (keeps door securely closed, unlike self closing hinge) 2 wooden door pulls; door slides into position and stays in place — no adjustment needed.

HEATER FENCE (for safety) of 2" x 2" or 2" x 4".

SUPER DEK flooring squares for walking area of floor—removable, washable, sanitary, non-skid, synthetic material.

VENTS lower neatly cut into room base; upper supplied for precut space.

LIGHT vapor-proof, wall-mounted P5511.

TRIM for exterior.

FINLANDIA OR HARVIA HEATER with built-in or wall-mounted control panel (including 60 min. timer).

STONES from Finland—peridotite, igneous type—best for heat retention and safety.

ACCESSORIES—bottomless wooden bucket with plastic liner #102N, dipper #106/40, wooden thermometer #0301K, bronze plexiglass bathing sign.

INSTRUCTIONS for assembly.

Note: Saunas must be customized for wheelchair accessibility.



FPF445S—5 SIDED, WITH FULL GLASS DOOR, WESTERN RED CEDAR INTERIOR AND 3 FRONT EXTERIOR SIDES. 2 BENCHES; OPTIONAL SIDELIGHT AND CEDAR COOLING BENCH WITH PIANO LEGS.



FPF56 WITH STANDARD EXTERIOR OF FINE-GRAIN RUFF-SAWN MAHOGANY. (OPTIONAL TOWEL HANGER.)

Note! FPF saunas have a finished height of 6' 6" (FPF34), 7' 0" (FPF44 to FPF68) and 7' 2" for FPF88 and larger. At least 3" ceiling clearance and wall clearance is needed for assembly.

Add A Work Of Art To Your Sauna With Finlandia's Exclusive Etched Sauna Doors.



OBSCURE GLASS
TOTALLY FROSTED FOR PRIVACY
STANDARD FIR RAILS
FGD-L LEFT HINGE SHOWN



POSITIVE IMAGE
SAUNA DESIGN
STANDARD FIR RAILS
FGD-R RIGHT HINGE SHOWN
(AVAILABLE IN NEGATIVE)



NEGATIVE IMAGE
RUSTIC SAUNA DESIGN
STANDARD FIR RAILS
FGD-R RIGHT HINGE SHOWN
(AVAILABLE IN POSITIVE)



MT. HOOD IMAGE
SCENIC DESIGN
STANDARD FIR RAILS
FGD-L LEFT HINGE SHOWN



MULTNOMAH FALLS IMAGE
SCENIC DESIGN
STANDARD FIR RAILS
FGD-R RIGHT HINGE SHOWN



LIGHTHOUSE IMAGE
SCENIC DESIGN
STANDARD FIR RAILS
FGD-L LEFT HINGE SHOWN

STANDARD DOORS

Our standard FINLANDIA Sauna doors are manufactured with solid wood rails, finished with V.G. fir lamination. The 16"x60" hermetically sealed double glass is tempered for safety. Clear glass is standard.

EXCLUSIVE GLASS OPTION

Our exclusive glass options have been custom designed and etched by an artist. When ordering this option, you have a choice of our unique Sauna design in positive or negative image, a choice of our beautiful scenic designs — the Mt. Hood image, the Multnomah Falls image — or the lighthouse image. Etchings are available for the 24" door size only, but custom sizes may be special ordered.

WHEN ORDERING SPECIFY:

FGD Door only—no jamb or hardware.

FGD-R Prehung with right hinge.

FGD-L Prehung with left hinge.

Hinge is determined by standing outside Sauna room, facing the door. Order FGD-R if door will open out to the right. Order FGD-L if door will open out to the left. FGD-L and FGD-R come complete with jamb, threshold, hinges, ball catch, and 2 wooden door pulls. Standard jamb is 4 3/4" and there is an extra charge for jambs over 5 1/2". Standard Sauna doors are 24"x 80" with RO of 26"x 82". Also available are 30"x 80" doors with RO of 32"x 82", and 36"x 80" (ADA handi-capped) with RO of 38"x 82".

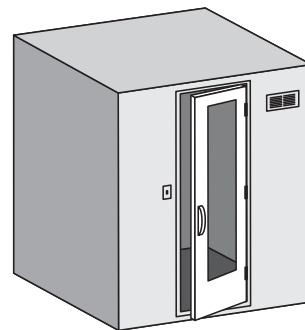

RIGHT HINGE
WHILE STANDING
OUTSIDE OF THE
SAUNA FACING
THE DOOR, THE
HINGES ARE ON
YOUR RIGHT.

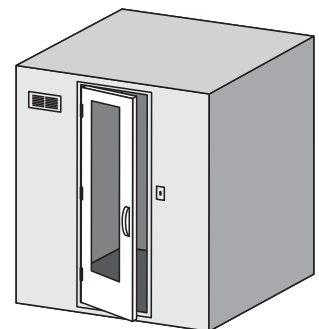

LEFT HINGE
WHILE STANDING
OUTSIDE OF THE
SAUNA FACING
THE DOOR, THE
HINGES ARE ON
YOUR LEFT.

The Sauna should be planned for ultimate enjoyment and relaxation. If possible, the space should be large enough for adequate seating and reclining. As a guide, allow 2' of bench space per person, for sitting purposes; it is necessary to have a 6' long bench to accommodate a reclining bather. Bench widths should be 20" for an upper bench, and about 20" for a lower bench. Do not plan a Sauna with angles (which will cut bench space and add wasted cubic footage). Two levels of benches are very important in a good Sauna—the upper bench is necessary to make use of the heat (which rises to the ceiling level). The lower bench can be used as a step up to the upper bench or as a sitting bench at the lower temperature level. For complete relaxation, a small dressing room with cooling bench or benches should be located next to the Sauna. This room might also be used as a combination cooling/exercise area.

CORRECT USE OF SPACE

Below is an example of the importance of pre-planning when designing a Sauna. Plan A and B have exact shape and size. Plan A uses the entire space as a Sauna, resulting in benches with little seating space and no reclining area. There is too much walking area—with a waste of space, building material and efficiency. Plan B creates 2 useable rooms from the same space, allows a Sauna with a more comfortable bench area, and leaves necessary walking space. The linen closet is a bonus.

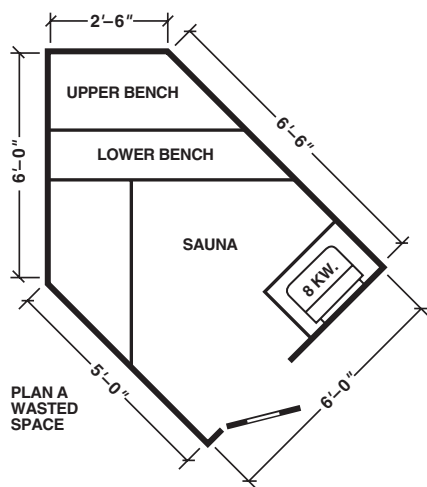

SAUNA DOOR

The Sauna door must open out and it should have no lock. It should be only 24" wide to prevent unnecessary loss of heat and warpage. The door should not open directly into a spa area, as chlorinated humidity will rust the hinges and warp the door. Do not put a handicapped door (36") on a Sauna unless the room is large enough to accommodate the movement of a wheelchair, with proper ramp and grab bar. (The metal wheelchair will get hot and will be uncomfortable for the operator. An attendant is necessary when a Sauna is intended for handicapped usage.)

THE IMPORTANCE OF A SHOWER

As a Sauna is a deep cleansing bath which opens pores and flushes out the body's impurities, it is necessary to use soap and water in a shower to rinse off this waste. For convenience, a shower should be located near the Sauna. However, do not put a shower head in the actual Sauna room as the humidity from the shower can harm the electric components in the Sauna heater. If a Sauna is located close to a pool or spa, a dressing room should be designed between the two areas to keep harmful chlorine vapors and humidity from damaging electrical and metal parts in the Sauna heater.

VENTILATION

It's important to have one lower (fresh air) vent and one upper (exhaust) vent in a Sauna to provide for good air circulation. Vents are not a safety concern, they are only for the bather's comfort. The lower vent provides fresh air for a comfortable atmosphere, and the upper vent dispels used air. The lower vent should be placed about 4" from the floor, close to the Sauna heater if possible, to allow fresh air to flow through the heater and enable it to function better. The upper vent

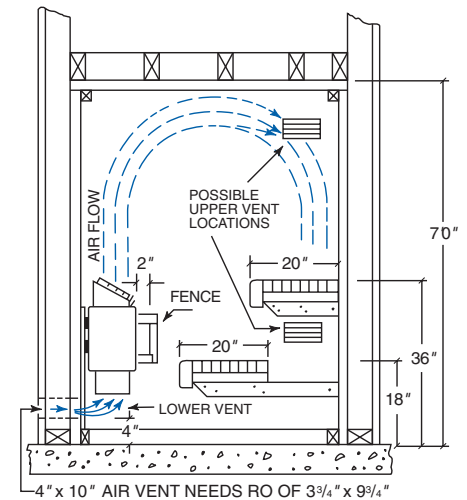
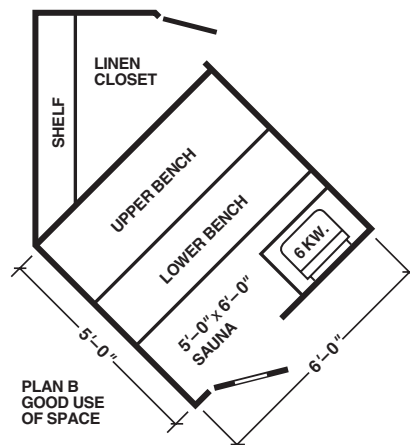

READ VENTILATION SECTION FOR CLARIFICATION.

can be anywhere; as low as 24" from the floor or as high as 6" from the ceiling. When both vents are open, air changes 4 to 6 times per hour. For faster heating, the upper vent should be closed when the Sauna is heating.

CEILING HEIGHT SHOULD BE 7' TO ALLOW ENOUGH HEAT AT BENCH AND HEAD LEVELS

It's important to reduce Sauna room height from a standard ceiling height of 8' to the Sauna norm of 7' from the finished floor. (Sauna ceiling can also be as low as 6'2".) An 8' ceiling wastes heat, energy and building material; and it increases the heating time. The diagram below shows the variance of temperature at various levels in the Sauna room.

SAUNA TEMPERATURE COMPARISONS

The importance of lowering the Sauna ceiling from 8' to 7' is shown in the following temperature comparison chart:

	195F	195F	
CEILING	195F	195F	CEILING
HEAD HEIGHT	145F	165F	HEAD HEIGHT
UPPER BENCH	127F	145F	UPPER BENCH
LOWER BENCH	95F	100F	LOWER BENCH
FLOOR	85F	85F	FLOOR

INCORRECT CEILING HEIGHT CORRECT CEILING HEIGHT

Notice that the Sauna room temperature is 20 degrees cooler at the upper bench level and at the bather's head level in the Sauna with the improper ceiling height of 8'. As the heat rises from floor to ceiling, there is too much wasted heat at the upper ceiling level and not enough heat at the bench levels where the bathers sit or lie.

Finlandia Has Saunas For All Areas



CUSTOM PRECUT WESTERN RED CEDAR WITH EVER READY HEATER.



PPF66 OUTDOOR SAUNA SHOWN WITH OPTIONAL WESTERN RED CEDAR EXTERIOR, ETCHED GLASS DOOR AND FRP66 ROOF PACKAGE. (BUILT ON SITE FROM PARTS.)

Finlandia Sets The Standard For Sauna Specification

All Saunas are not manufactured equally! An architect, designer, or contractor is entrusted by his client to make the best selection of product. As many specifiers may not be Sauna users or experts, they need to make an informed comparison among Sauna manufacturers.

FINLANDIA Sauna products, created in 1964, is the oldest Sauna manufacturer under original ownership and the only major supplier to manufacture Saunas exclusively. As Saunas are not a sideline with our company, we fully focus on production and improvement of Sauna products for our customers. Throughout the years, FINLANDIA has manufactured only one quality—the very best—and we have been the pacesetter because of our superior products, choicest raw materials, and careful craftsmanship. Since 1964, we have set the standard for Sauna specification.

FINLANDIA's standard of 1" x 4" paneling for Sauna interior does not require additional backing, provides greater heat retention and R value, and will not shrink like the ½" x 4" material supplied by other manufacturers.

Note! Other manufacturers do not specify the thickness of their wall and ceiling paneling because they use ½" material instead of 1" x 4" material. ½" material is substandard for the hot Sauna environment.

For consumer protection, thickness of material should be specified, to prevent manufacturer from supplying thinner and cheaper boards. (See page 11 for comparisons in wood thicknesses.)

FINLANDIA's standard benches are preconstructed for strength and durability out of 2" x 2" tops with ½" spacing and 2" x 4" facing. Others use 1" x 3" or 1" x 4" bench tops and some do not even pre-build their benches, but provide a pile of boards with a "How to build" plan. (See page 11 for bench comparisons.)

FINLANDIA uses lightweight, sanitary, non-porous Super Dek for standard removable flooring. Unsanitary wooden duckboard flooring (supplied by many competitors) wears out quickly, is difficult and awkward to remove for cleaning, and should never be used in commercial Saunas. (See page 11 for illustrated comparisons.)

FINLANDIA's exclusive Sauna doors have solid fir rails with a spacious window to allow natural light to penetrate the room. (See page 8 for more door details.)

The modern trend for commercial Saunas seems to be larger and larger rooms. Larger is not necessarily better, as a very large room requires the use of two commercial Sauna heaters, and the installation and operation can become costly. Large groups of people do not normally gather in the Sauna at one time, and as a 10' x 12' room can seat about 15 people, it is large enough for even a sports team. A 12' x 12' room is an example of oversize! Sauna heater placement in a large room is very important—to prevent cold spots and to allow even heating.

Note to architect, designer, or spec writer: you should not overlook the basic Sauna properties of construction and function, in lieu of decorative options such as lighting, windows, sound systems, etc. offered by manufacturers who are not strong in quality and performance. FINLANDIA builds Saunas — to last.

Finlandia's Paneling Exceeds The Industry's Standards

FINLANDIA'S 1" X 4" T&G PANELING MAKES A DIFFERENCE!

Unlike our competitors, we advertise our wood thickness and we deliver what we advertise. We exceed the industry's standard of 1/2" x 4"—we have used 1" x 4" since 1964.



FINLANDIA'S 1" x 4" BOARD has a small v joint pattern. The 3/32" v joint gives a neat appearance and allows the larger shoulder to hide nails or fasteners. The 1/4" tongue allows fastening without splitting. Our 1" x 4" board has the highest R value, greatest heat retention, and does not require plywood backing for added strength. Our material is 50% to 100% vertical grain. *Max. load strength 572# sq. in. (T & G Western Red Cedar tested by Louisiana Pacific Lab).*



COMPETITOR'S 5/8" x 4" BOARD has a profile pattern which is common in knotty spruce European Saunas. Boards must be undercut with grooves to help prevent cupping and warping. This pattern leaves a valley between boards which cannot hide nails—there is also lower R value. Boards are almost 100% flat grain.



COMPETITOR'S 1/2" x 4" BOARD has a reverse v pattern (v on both sides) which creates a small 1/8" tongue. The small shoulder will not easily hide nails or fasteners and the tongue and shoulder can split when nailing. The thinner board has a lower R value and natural shrinkage at the groove will allow some heat loss. 1/2" x 4" boards can be flat or wide grain with some vertical grain and should be backed with plywood for additional strength and R value. *Max. load strength 341# sq. in. (T & G Western Red Cedar tested by Louisiana Pacific Lab).*



EXAMPLE OF SHRINKAGE IN A 1/2" THIN BOARD.

All wood shrinks in the hot Sauna environment, so the thickness of the wood used is very important! The thicker the wood, the less shrinkage. The above photo shows 1/2" cedar with 1/8" tongue after a few month's exposure in the Sauna. The wood has shrunk exposing unsightly nails and allowing cracks for heat to escape. This is why FINLANDIA Sauna still uses our old standard of 1" x 4" material instead of the industry standard of 1/2" x 4".



FINLANDIA'S SUPER DEK FLOORING. 12" X 12" SQUARES.



COMPETITOR'S WOOD SLAT FLOORING. (HAS THIS FLOOR EVER BEEN CLEANED?)

Finlandia's Flooring Is Superior

Finlandia uses sanitary Super Dek flooring. Unlike wood slats, it is easy to remove and clean. Wood slats are awkward and heavy so they are seldom removed and the floor underneath becomes an odor and bacteria collector. Super Dek is especially superior for commercial use.

FINLANDIA'S FLOORING

- Sanitary
- Comfortable for walking
- Durable
- Flexible
- Does not stain or discolor
- Resists odor & bacteria
- Water runs through
- Lightweight
- Easy to remove for cleaning
- Easy to install—snaps together

COMPETITOR'S FLOORING

- Unsanitary
- Stains & discolors
- Absorbs perspiration and odors
- Rigid—rocks on uneven floor
- Heavy and clumsy to remove for cleaning
- Breakable
- Fasteners corrode
- Hard to clean

Max Load (lbs.)	0	500	1000	1500	2000	2500
2 x 4				1809 lbs.	Finlandia Bench Facing	
2 x 2		902 lbs.	Finlandia Bench Tops			
1 x 4 S4S		605 lbs.	Competitors Bench Tops			
1 x 4 T&G		572 lbs.	Finlandia FPC Wallboard			
7/16 x 4 T&G	364 lbs.	Finlandia FPF Exterior				
1/2 x 4 T&G	341 lbs.	Competitors FPC Wallboard				

Load Strength of Western Red Cedar Boards
Independently Tested by Louisiana-Pacific Corporation Advanced Technology Center

Finlandia Builds Better Benches

There's no comparison! Our benches have the greatest strength and durability and are made from the finest materials.

FINLANDIA'S 2" x 2" BENCH TOPS

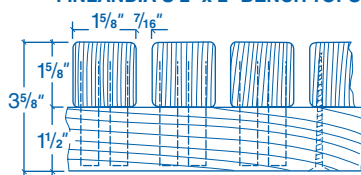

- Fastening Ability:** 1%" penetration for greatest strength and durability
- Tendency to Cup:** None
- Water Retention: (Perspiration)** Virtually none; narrower tops will not retain perspiration
- Vertical Grain:** Always
- Air Circulation:** Excellent; narrower boards allow greater air circulation and less water retention
- Advantages:** Greater durability, better holding strength, neater look. No splinters. Fastened from the bottom, leaving no exposed metal to burn bather.
- Disadvantages:** None for purchaser. Better materials, higher costs for manufacturer.
- Max. Load Strength:** 902# sq. in. (S4S Western Red Cedar tested by Louisiana Pacific Lab.)

COMPETITOR'S 1" x 4" BENCH TOPS

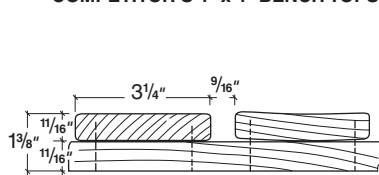

- Fastening Ability:** Minimal; only 5/8" penetration
- Tendency to Cup:** Moderate; elevates with flat grain
- Water Retention:** High; due to width of boards and tendency to cup
- Vertical Grain:** Occasionally
- Air Circulation:** Less, due to width of boards
- Advantages:** All advantages are to the manufacturer. Cheaper to make, lower cost of materials, takes less time to manufacture!
- Disadvantages:** Questionable durability, will not support heavy weight, tends to sag with use, high tendency for flat grain boards to cup and splinter. Less air circulation.
- Max. Load Strength:** 602# sq. in. (S4S Western Red Cedar tested by Louisiana Pacific Lab.)



HINTS FOR NAILING T&G: Use 5p galvanized small head siding nails and nail at a 45 degree angle for the best holding power. Use a nail punch to hide the nail. Or, use 1 1/4" galvanized staples in an air gun.

Finlandia Specifications For Architects/Contractors

13 24 16/FIN
BuyLine 2663

GENERAL CONTRACTOR SPECIFICATIONS:

Framing of walls and ceiling shall be of dry Douglas Fir, construction grade no.1 or 2, 16" center. Use pressure treated plates (against concrete)

Ceiling shall be 7'0" from finished floor to bottom of ceiling joists (16" center)

Door shall be roughed in at 26" x 82" and must open out

Insulation of walls and ceiling shall be of R13 fiberglass batts

Drywall shall be 5/8" firewall (use drywall only if required by local building codes)

Flooring shall be of hard surfaced, water-proof type — concrete, ceramic tile, heavy-duty seamless vinyl

Floor Drain is recommended for new construction and is essential for commercial and public Saunas

Exterior Walls shall be of drywall, paneling, tile, etc. and exterior painting, door finishing, etc. shall be included

ELECTRICAL CONTRACTOR SPECIFICATIONS:

(Must be licensed and bonded)

Rough-in for Sauna controls, heater, room light shall be as per FINLANDIA wiring diagram (provided with control box or in heater box)

Hookup of controls, heater, light shall be as per FINLANDIA wiring diagram (see pages 3-5 for wire size, amperage, etc.) COPPER WIRE ONLY; NO GFI

FINLANDIA SAUNA CONTRACTOR SPECIFICATIONS:

Walls and Ceiling shall be 1" x 4" select, certified, kiln-dried (moisture content not exceeding 11%) T&G, v joint, clear 1" x 4" Western Red Cedar, clear 1" x 4" vertical grain Redwood, clear 1" x 4" Alaska Yellow Cedar, or clear 1" x 4" vertical grain Western Hemlock. All boards shall be blind nailed with 5p galvanized, hot dipped nails, or power stapled with 1/4" crown, 1 1/2" galvanized staples.

The following specs shall include and match one of the four woods chosen above:

Benches shall be clear S4S kiln-dried 2" x 2" tops with 1/2" spacing and 2" x 4" facing; glued and fastened with exposed nails countersunk. Bench tops shall be fastened from bottom to eliminate exposed metal.

Door shall be FGD 2'0" x 6'8" of vertical grain Douglas Fir rails and clear hermetically sealed, double glass, tempered (16" x 60") with casing, jamb, and threshold of fir or Hemlock

Door Hardware shall be (3) 4" x 4" butt hinges, lvs ball catch MP347B3. (2) wooden door pulls 080

Vents shall be (2) 4" x 10" louvered V10 for upper wall placement and lower wall placement. RO=3 3/4" x 9 3/4". See diagram pg. 13.

Removable Flooring shall be Super Dek interlocking 12" squares — sanitary, non-skid surface in terra cotta or tan color — over walking area of base floor

Light shall be wall-mounted, vapor-proof Progress P5511, satin finish cast aluminum, rated for 75 watts

Sauna Heater shall be FINLANDIA or HARVIA model ...as per cubic room footage and voltage requirements (see chart pgs. 3-5)

Heater Fence shall be of 2" x 2" or 2" x 4" and shall be placed 2 1/2" away from Sauna heater

Temperature Control/Contactor panel shall be model...from pg. 4-5

Accessories per pg. 6 or 7

Stones shall be a peridotite, heat tested, igneous type from Finland

Type C Building Foil (vapor barrier)

Precut and Prefab Saunas shall be as per specifications pgs. 7 & 8

Warranty shall be 1 yr. on room materials and workmanship and 5 yr. limited warranty on Sauna heaters when installed according to FINLANDIA specifications and wiring information

Maintenance

FINLANDIA Sauna heaters and rooms require minimum care and maintenance. Basic household methods, including cleaning of Sauna room floor with a product such as Pine Sol, and occasional scrubbing of benches with a mild soap, is necessary for sanitary and odor-free atmosphere. When wood becomes dark or stained from perspiration, a light sanding will help to restore its beautiful appearance. Do not use sealers, paint or varnish on interior wood, as toxic vapors could be dangerous in the high temperatures of a Sauna.

NOTE: When figuring room capacities for number of bathers, allow 2' of bench space per person.

FINLANDIA SAUNA IS THE ONLY U.S. COMPANY WHICH OFFERS A CHOICE OF THE WORLD'S BEST SAUNA WOODS:

100% clear Western Red Cedar, clear California Redwood, clear Alaska Yellow Cedar, and clear Western Hemlock (all are 1" x 4").

The best known and most widely used of the West Coast cedars is WESTERN RED CEDAR. It has the most beautiful color variation, has a refreshing aroma, and is dry-rot resistant. Because it's the softest wood, it is least hot to sit on or lean against.

Our CALIFORNIA REDWOOD is A and better, is the most fire resistant, most dry-rot resistant, most termite resistant, and does not warp.

ALASKA YELLOW CEDAR is an exclusive white cedar with a pungent aroma. It feels almost silky to the touch, and has a beautiful appearance.

Clear WESTERN HEMLOCK is an excellent wood for people who have wood allergies—it has no aroma and no resins.

Finlandia Sauna does not use inexpensive woods such as thin knotty spruce which has a tendency to cup, shrink, warp and crack; (and some knots come loose when the pitch and resin around them dries in the high heat of the Sauna). Many European Saunas, however, are built from knotty spruce as it has been the available wood for centuries. Knotty spruce cannot be used for benches as it gets too hot, and the knots and pitch can burn the bather; so African Abachi is imported for benches. Abachi is a clear wood and it's comfortable for sitting; but it has a peculiar, unpleasant odor. FINLANDIA uses only clear Western softwoods with the proper matching softwood for benches.

Note to architect before specifying: To be sure that your customer gets the best wood, ask for lumber samples from Sauna suppliers to compare wood qualities and thickness. Finlandia is happy to supply samples, upon request.



FINLANDIA THE PACESETTERS
& **HARVIA SAUNAS**

Finlandia Sauna Products, Inc.
14010-B S.W. 72nd Avenue, Portland, OR 97224-0088.
Telephone Toll Free: 1-800-354-3342.
In Oregon: 503-684-8289. FAX: 503-684-1120.
Email: info@finlandiasauna.com Web page: finlandiasauna.com
Copyright 2010, FINLANDIA Sauna Products, Inc.

We reserve the right to make technical changes. Printed in the U.S.A.

HARVIA
Sauna