

Data Sheet R16 MANUAL SHADE WITH BLACKOUT

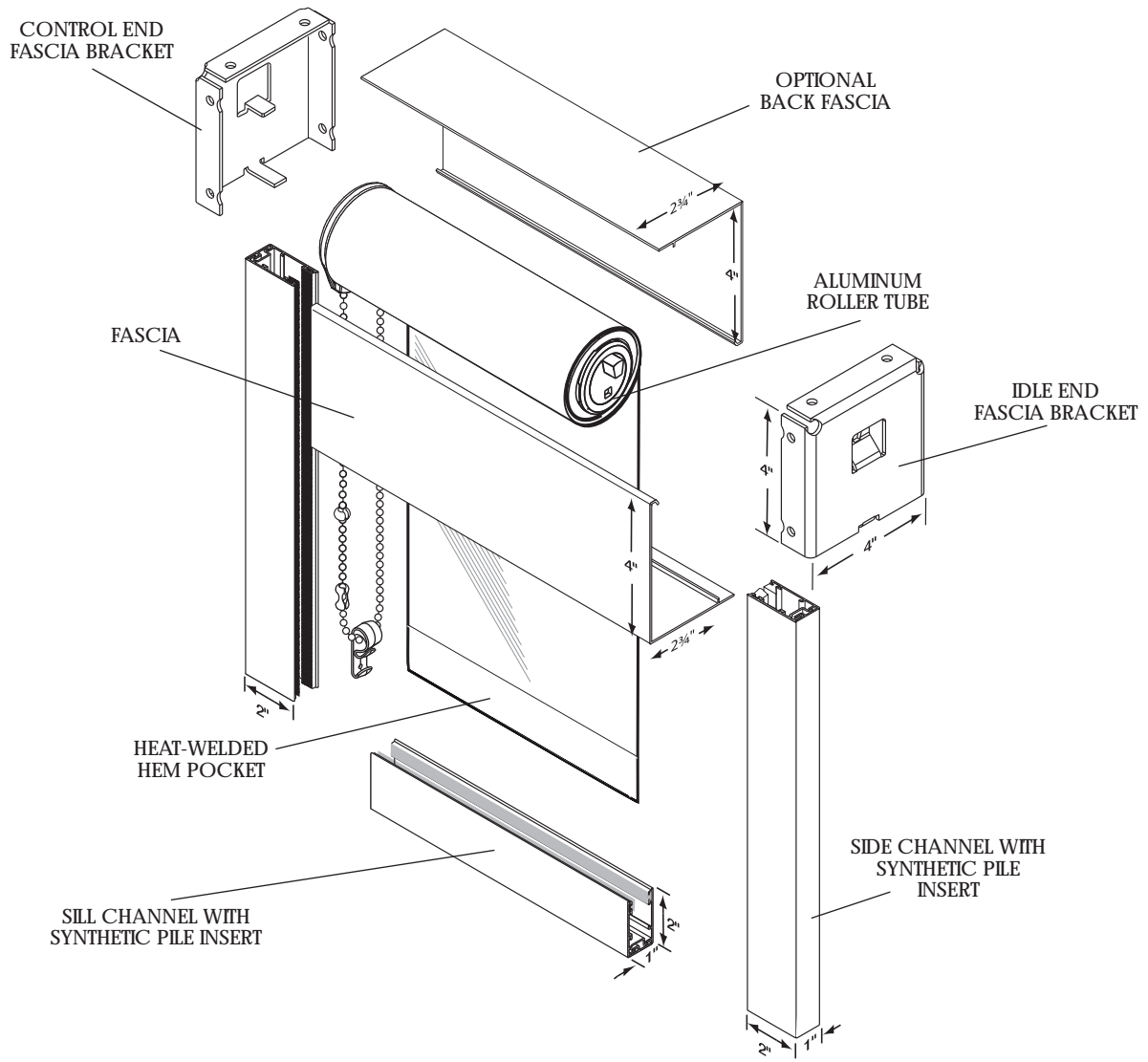

- R16 clutch system is designed to lift shades weighing up to sixteen pounds.
- Shades are raised and lowered by means of a #10 stainless steel bead chain.
- Roller tube is extruded aluminum engineered with a channel to accept fabric spline making the shade panel easy to remove.
- Hem bar is extruded aluminum and completely enclosed in a heat-welded hem pocket.
- Fascia measures 3" high with a 2-1/4" bottom lip and snaps onto 3" X 3" fascia bracket or 4" high with a 2-3/4" bottom lip and snaps onto 4" X 4" fascia bracket. Available in white, vanilla, clear anodized, bronze or black. Optional back fascia.
- Side and sill channels are 2" x 1" extruded aluminum with synthetic pile inserts to eliminate light leakage. Available in white, clear anodized or bronze.
- Optional lift assist reduces pull force allowing easy lifting of larger shades.