

Data Sheet R8 MANUAL SHADE WITH BLACKOUT

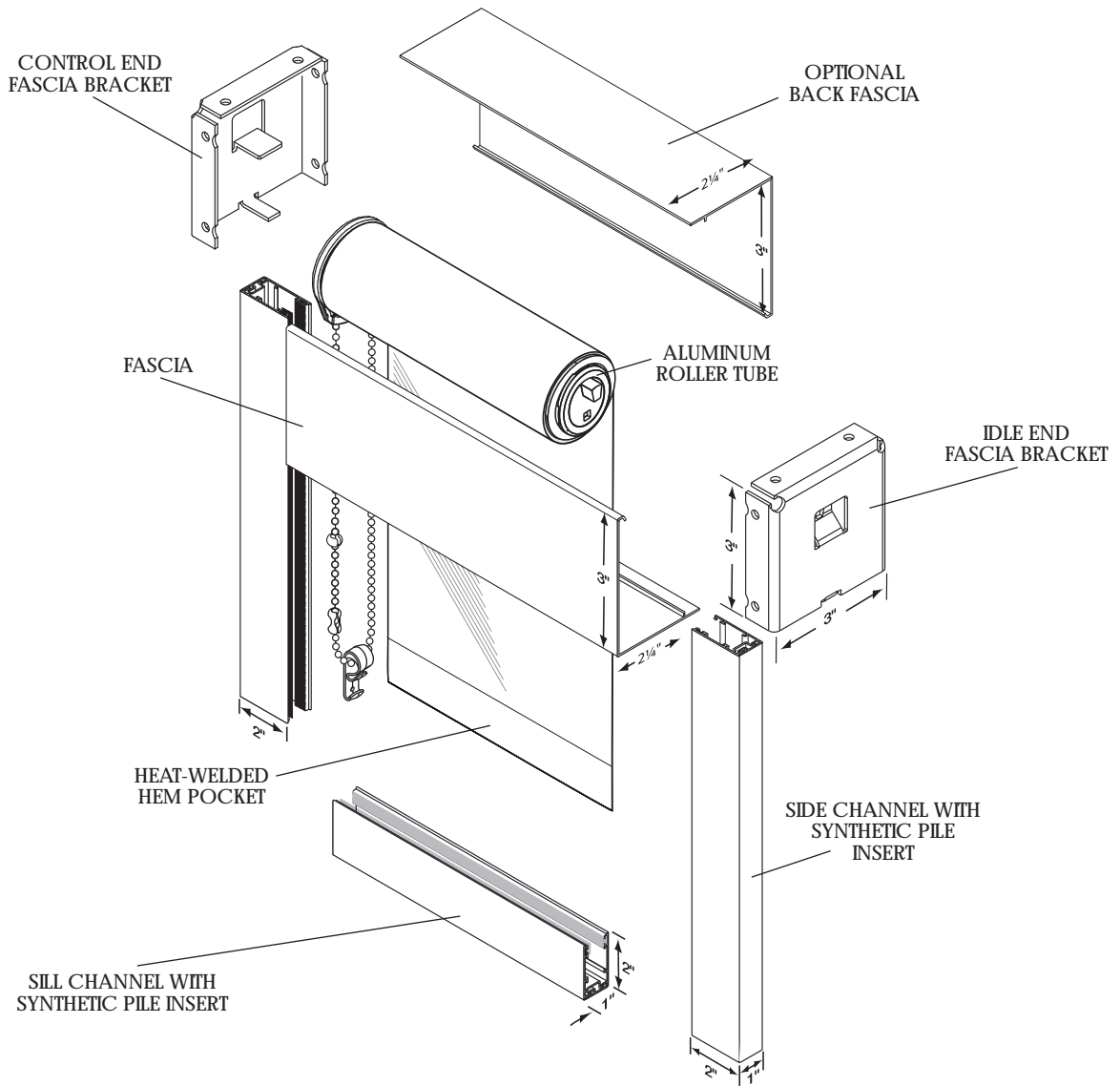

- Shades are raised and lowered by means of a #10 stainless steel bead chain.
- Roller tube is extruded aluminum engineered with a channel to accept fabric spline making the shade panel easy to remove.
- Hem bar is extruded aluminum and completely enclosed in a heat-welded hem pocket.
- Fascia measures 3" high with a 2-1/4" bottom lip and snaps onto 3" x 3" fascia bracket. Available in white, vanilla, clear anodized, bronze or black. Optional back fascia.
- Side and sill channels are 2" x 1" extruded aluminum with synthetic pile inserts to eliminate light leakage. Available in white, clear anodized or bronze.